

Application guidelines

Danfoss scroll compressors **SH090 to SH485 - single**

50 Hz - 60 Hz - R410A



Scroll compression principle.....	4	System design recommendations	27
Features.....	5	General.....	27
Compressor model designation	6	Essential piping design recommendations...	27
Nomenclature	6	Refrigerant charge limit.....	28
Technical specifications.....	7	Off-cycle migration	29
50-60 Hz data	7	Liquid flood back	31
Dimensions	8	Specific application recommendations 32	
SH090-105-120-140* and 161*	8	Low ambient application	32
SH 140 and 161 code 3 and SH184.....	9	Low load operation	33
SH180-240-295	10	Brazed plate heat exchangers.....	33
SH380-485 (Except code 3)	11	Electronic expansion valve.....	33
SH380 code 3.....	12	Reversible heat pump systems	33
Connection details	13	Water utilizing systems.....	35
Electrical data, connections and wiring 13		Sound and vibration management	36
Motor voltage.....	14	Starting sound level.....	36
Wiring connections	14	Running sound level	36
IP rating.....	15	Stopping sound level.....	36
Terminal box temperature.....	15	Installation.....	38
Three phase electrical characteristics	16	Compressor handling and storage.....	38
Danfoss MCI soft-start controller	17	Compressor mounting.....	38
General wiring information.....	18	Compressor holding charge	39
Motor protection.....	20	System cleanliness.....	40
Voltage imbalance.....	21	Tubing	40
Approval and certifications.....	22	Brazing and soldering	40
Approvals and certificates	22	System pressure test	41
Pressure Equipment.....	22	Leak detection	42
Low voltage directive.....	22	Vacuum evacuation and moisture removal..	42
Machines directive	22	Filter driers.....	42
Internal free volume.....	22	Refrigerant charging.....	43
Operating conditions.....	23	Insulation resistance and dielectric strength	43
Refrigerant and lubricants	23	Commissioning	43
Motor supply	24	Oil level checking and top-up.....	43
Compressor ambient temperature	24	Ordering information and packaging..	44
Application envelope.....	24	Packaging	44
Discharge temperature protection	25	Ordering information	45
High and low pressure protection.....	25	Accessories.....	47
Cycle rate limit.....	26		

In a Danfoss SH scroll compressor, the compression is performed by two scroll elements located in the upper part of the compressor.

Suction gas enters the compressor at the suction connection. As all of the gas flows around and through the electrical motor, thus ensuring complete motor cooling in all applications, oil droplets separate and fall into the oil sump. After exiting the electrical motor, the gas enters the scroll elements where compression takes place. Ultimately, the discharge gas leaves the compressor at the discharge connection.

The figure below illustrates the entire compression process. The centre of the orbiting scroll (in grey) traces a circular path around the centre of the fixed scroll (in black). This movement creates symmetrical compression pockets between the two scroll elements. Low-pressure suction gas is trapped within each crescent-shaped pocket as it gets formed; continuous motion of the orbiting scroll serves to seal the pocket, which decreases in volume as the pocket moves towards the centre of the scroll set increasing the gas pressure. Maximum compression is achieved once a pocket reaches the centre where the discharge port is located; this stage occurs after three complete orbits. Compression is a continuous process: the scroll movement is suction, compression and discharge all at the same time.

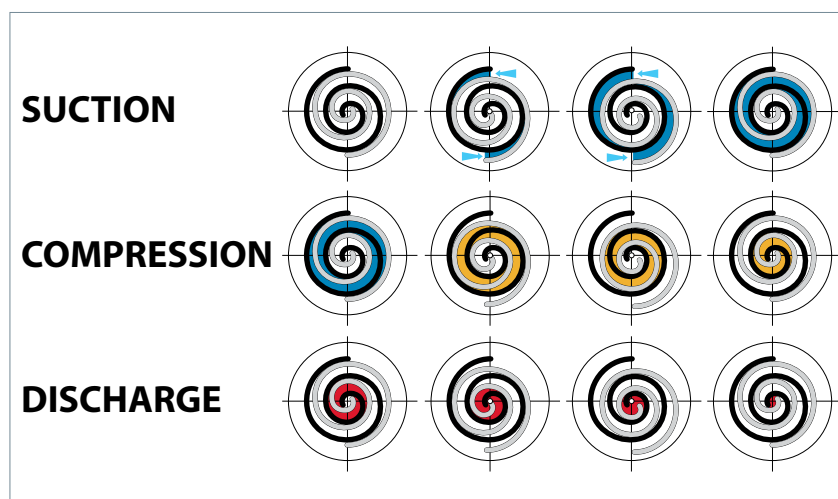
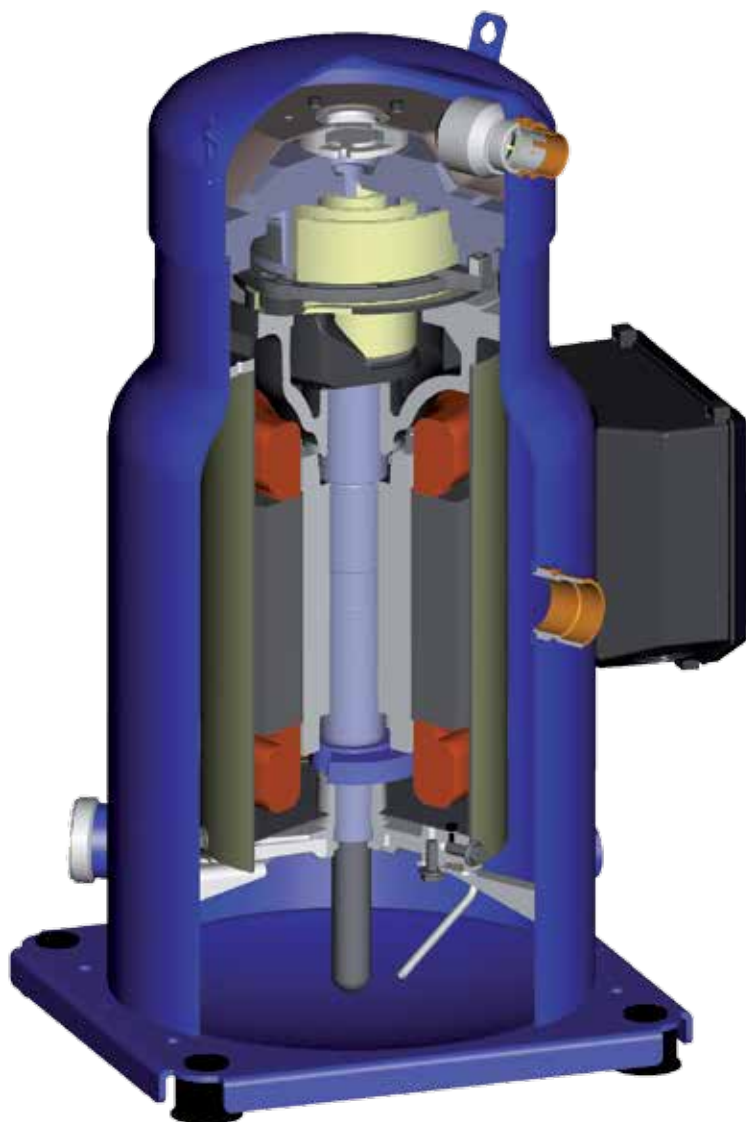

Application Guidelines

Features

SH range is composed of SH090-105-120-140-161-184 (light commercial platform) and SH180-240-295-380-485 (large commercial platform).

The SH090-105-120-140-161-184 compressors benefit from a further improved design to achieve the highest efficiency.

- Gas circulation, motor cooling and oil behaviour are improved on light commercial platform models by a new patented motor cap design.
- Part protection and assembly reduces internal leaks and increases life durability.
- Improved part isolation reduces greatly acoustic levels.

- Gas intake design induces higher resistance to liquid slugging.

The SH485 compressors include additional features for enhanced protection and efficiency:

- integrated discharge gas temperature protection,
- intermediate discharge valves for higher seasonal efficiency.
- patented gas path flow.

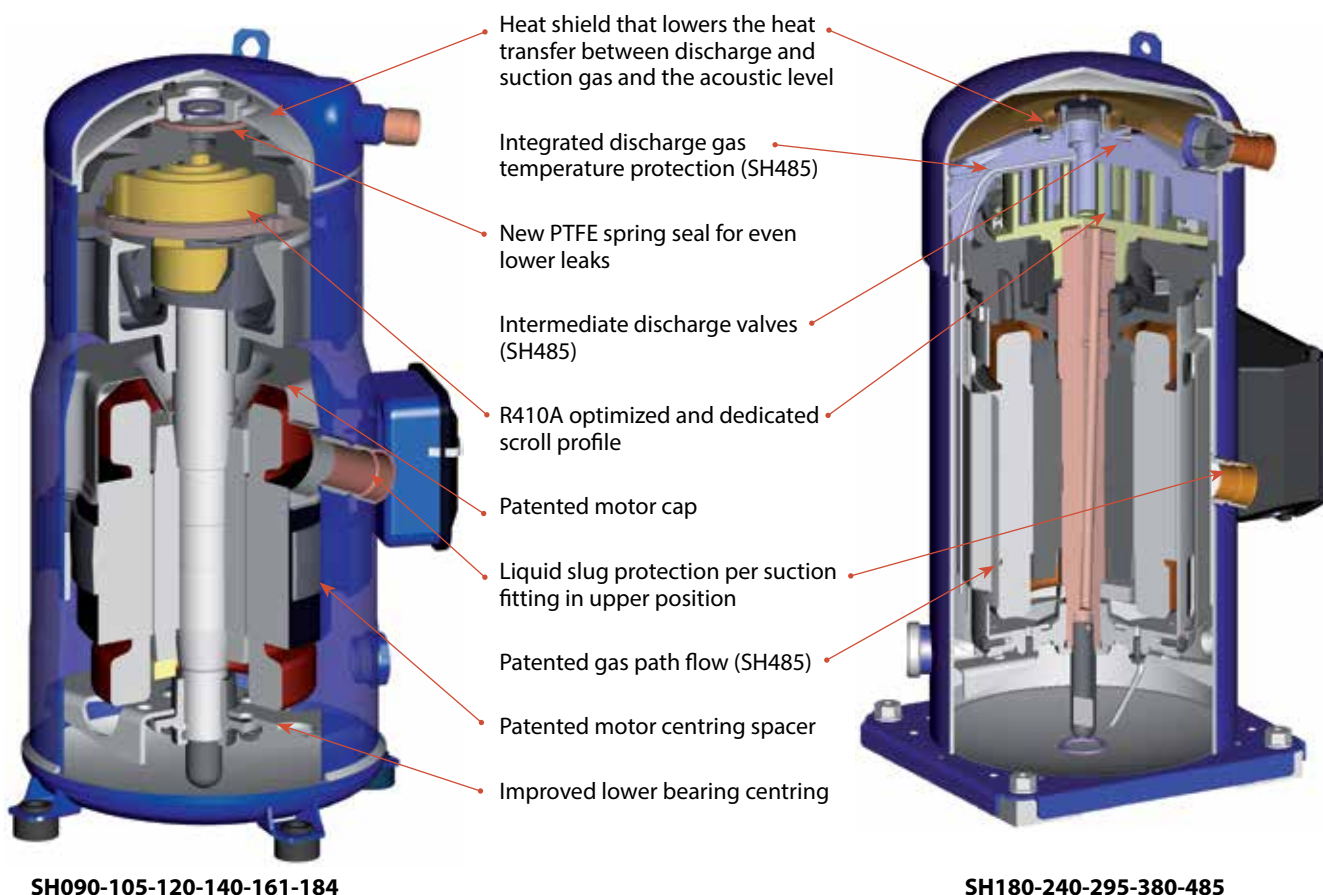

Danfoss SH scroll compressors for R410A are available as single compressors. The example below presents the compressor nomenclature which equals the technical reference as shown on the compressor nameplate.

Code numbers for ordering are listed section "Ordering information and packaging".

For tandem and trio assemblies, please refer to the Danfoss SH scroll compressor Parallel Application Guidelines, FRCC.PC.008.

Nomenclature

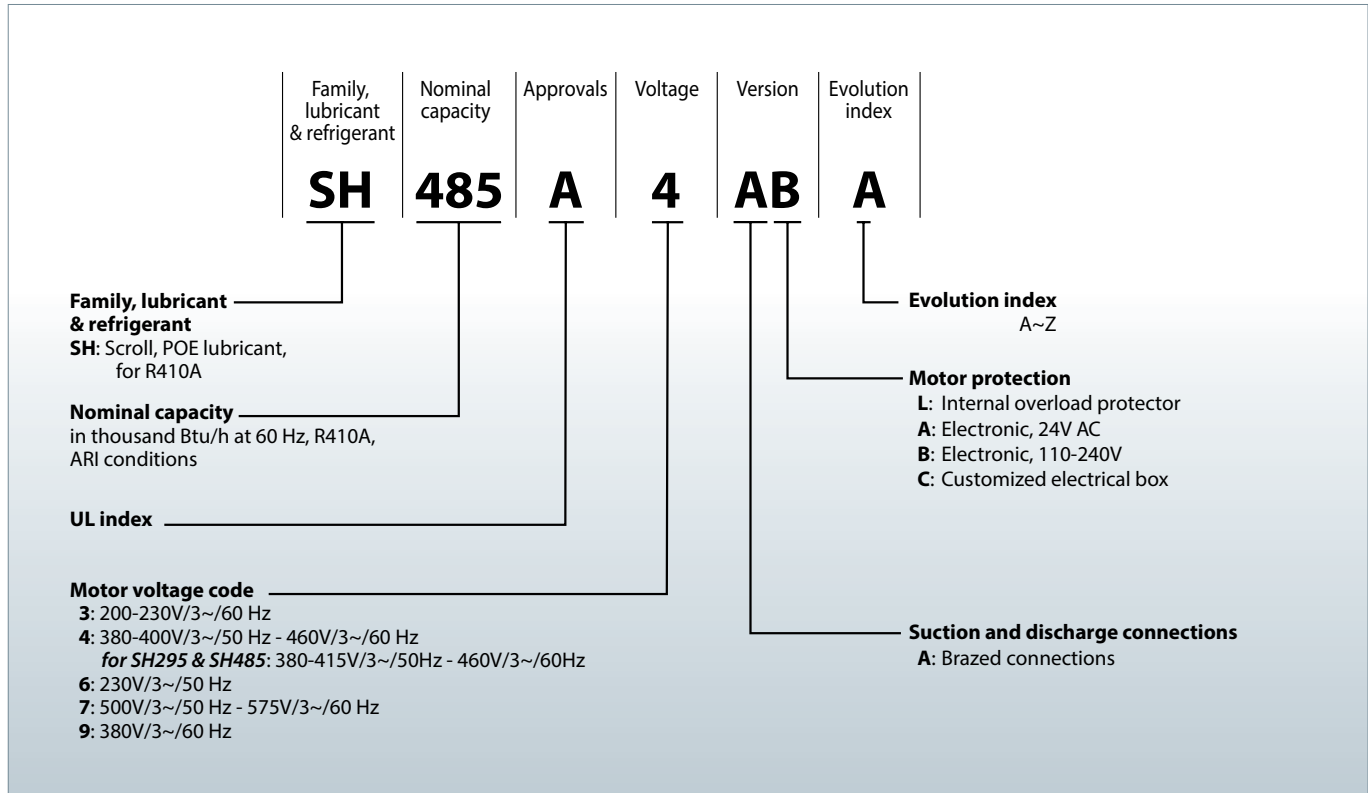

50-60 Hz data

Model	Nominal tons 60 Hz	Nominal cooling capacity		Power input	COP	E.E.R.	Swept volume	Displacement ①	Oil charge	Net weight ②	
	TR	W	Btu/h	kW	W/W	Btu/h/W	cm ³ /rev	m ³ /h	dm ³	kg	
50 Hz	SH090	7.5	22300	76100	7.19	3.10	10.58	88.40	15.4	3.0	58.0
	SH105	9	26800	91500	8.47	3.17	10.82	103.50	18.0	3.3	64.0
	SH120	10	30000	102400	9.46	3.17	10.82	116.90	20.3	3.3	64.0
	SH140	12	34700	118400	10.58	3.28	11.19	133.00	23.1	3.3	67.0
	SH161	13	38800	132400	12.15	3.19	10.89	151.70	26.4	3.3	69.0
	SH184	15	44700	152600	13.73	3.25	11.09	170.30	29.6	3.6	71.5
	SH180	15	44500	151900	13.87	3.21	10.96	170.20	29.6	6.7	108.0
	SH240	20	59700	203800	18.50	3.23	11.02	227.60	39.6	6.7	108.0
	SH295*	25	73200	249800	22.51	3.25	11.09	276.20	48.1	6.7	111.0
	SH380	30	90500	308900	28.18	3.21	10.96	345.00	60.0	6.7	159.0
SH485	40	116400	397300	35.65	3.26	11.13	442.60	77.0	6.7	175.0	
60 Hz	SH090	7.5	27100	92500	8.57	3.16	10.78	88.40	18.6	3.0	58.0
	SH105	9	32100	109600	9.96	3.22	10.99	103.50	21.8	3.3	64.0
	SH120	10	36800	125600	11.25	3.27	11.16	116.90	24.6	3.3	64.0
	SH140	12	42300	144400	12.77	3.31	11.30	133.00	27.9	3.3	67.0
	SH161	13	47200	161100	14.43	3.27	11.16	151.70	31.9	3.3	69.0
	SH184	15	54000	184300	16.45	3.28	11.19	170.30	35.8	3.6	71.5
	SH180	15	54300	185300	16.58	3.27	11.16	170.20	35.7	6.7	108.0
	SH240	20	72200	246400	22.10	3.27	11.16	227.60	47.8	6.7	108.0
	SH295*	25	88500	302000	27.21	3.25	11.09	276.20	58.0	6.7	111.0
	SH380	30	109600	374100	33.99	3.22	10.99	345.00	72.3	6.7	159.0
SH485	40	140600	479900	43.28	3.25	11.09	442.60	92.9	6.7	175.0	

① Displacement at nominal speed: 2900 rpm at 50 Hz, 3500 rpm at 60 Hz

② Net weight with oil charge

TR: Ton of Refrigeration,
EER: Energy Efficiency Ratio
COP: Coefficient Of Performance,

Standard rating conditions: ARI standard
Refrigerant: R410A

Evaporating temperature: 7.2 °C
Condensing temperature: 54.4 °C

Superheat: 11.1 K
Subcooling: 8.3 K

Subject to modification without prior notification.

Data given for motor code 4 compressor, for full data details and capacity tables refer to Online Datasheet Generator: www.danfoss.com/odsg

* SH295 replaces SH300. SH300 model remains available for after-market, please refer to datasheets for technical details.

SH090-105-120-140* and 161*

(* except code 3)

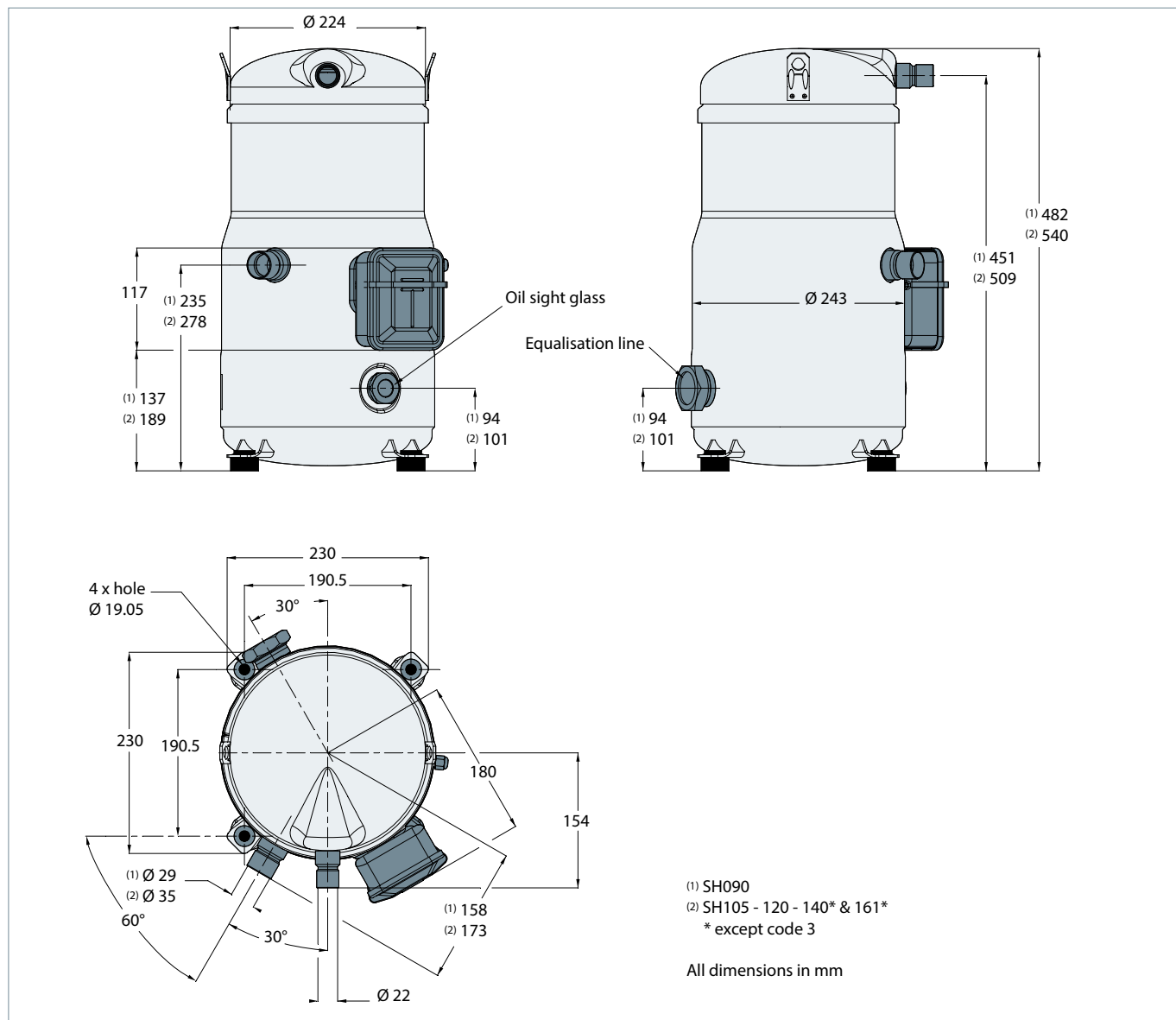

Flexible grommet

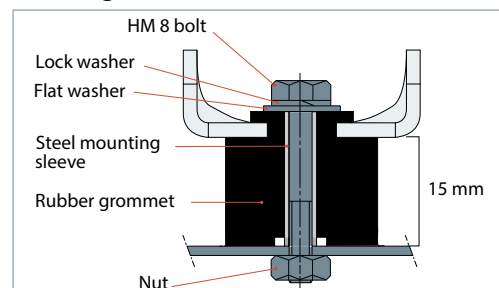

SH 140 and 161 code 3 and SH184

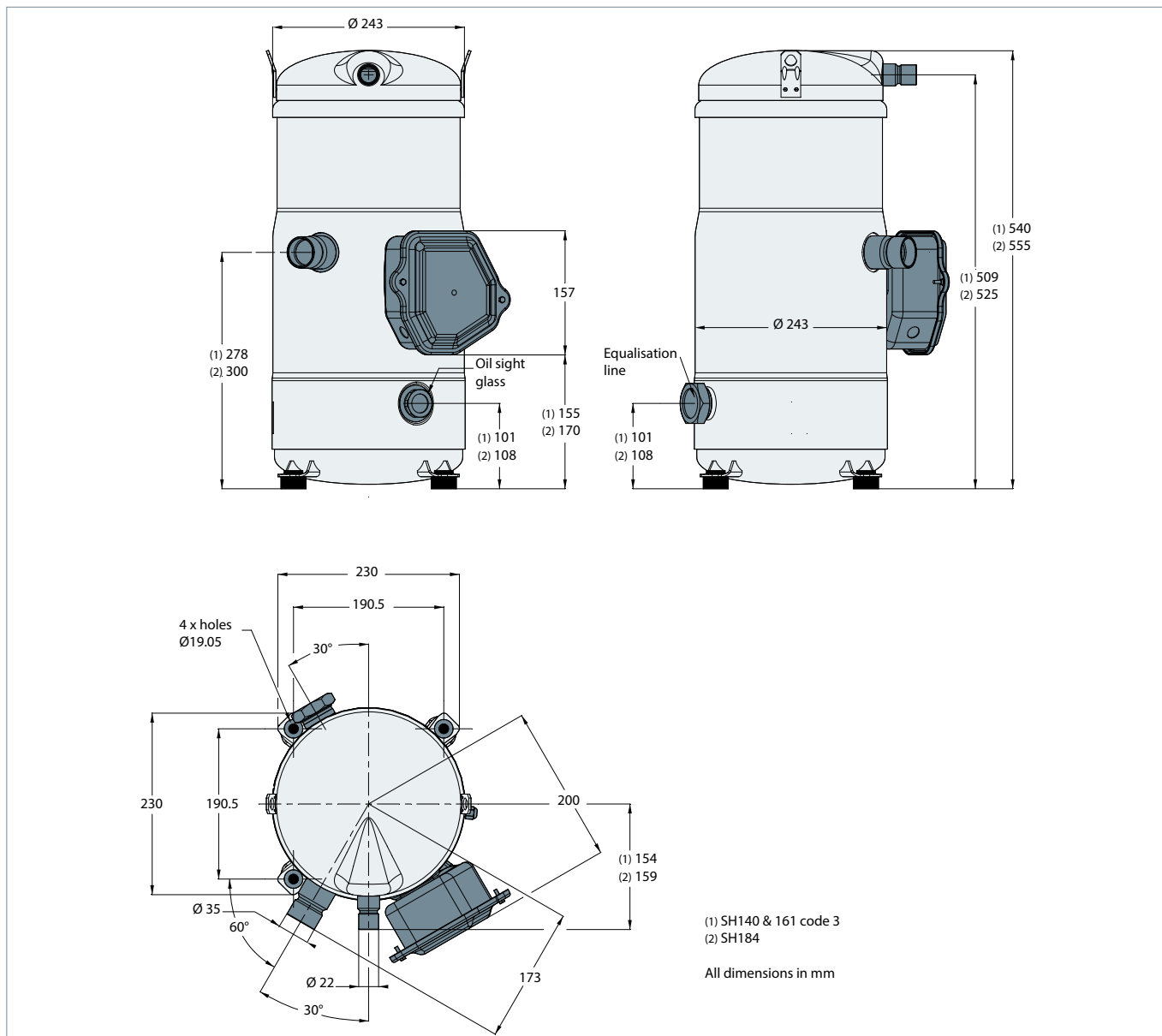

Flexible grommet

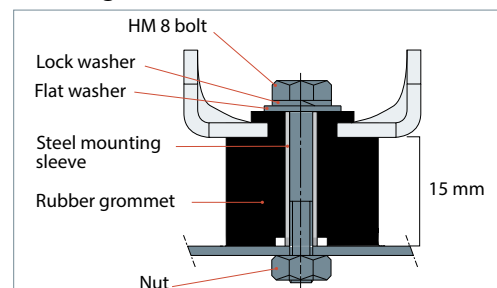

SH180-240-295

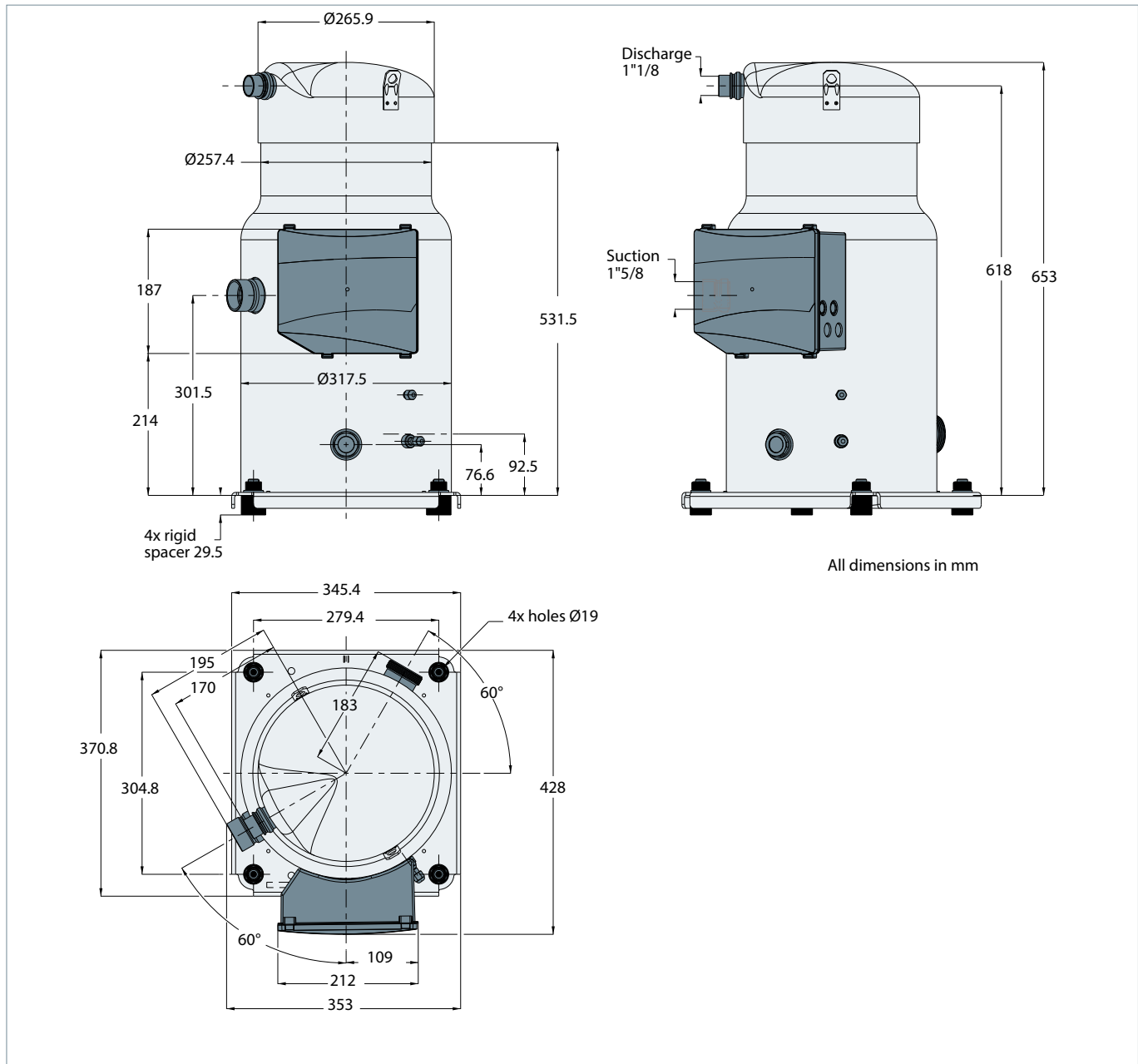

Rigid spacer

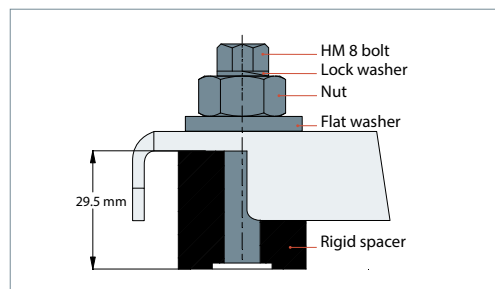

Flexible grommet

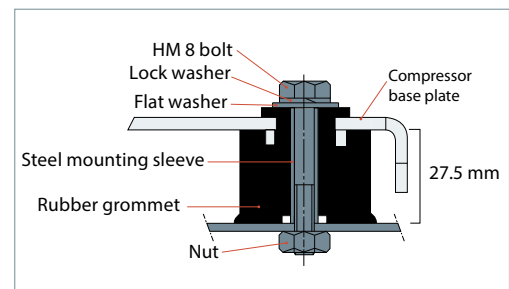

SH380-485 (Except code 3)

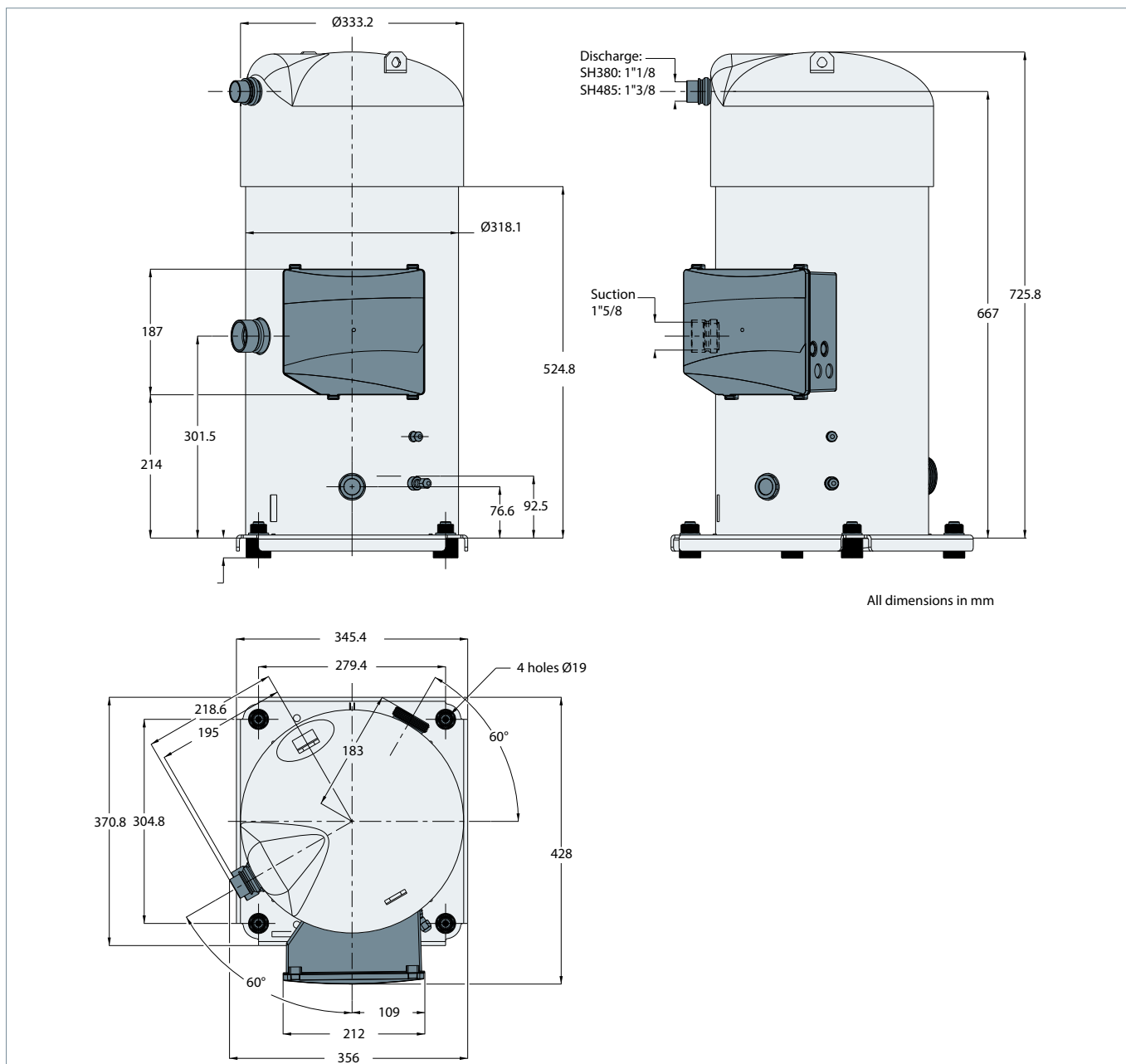

Rigid spacer

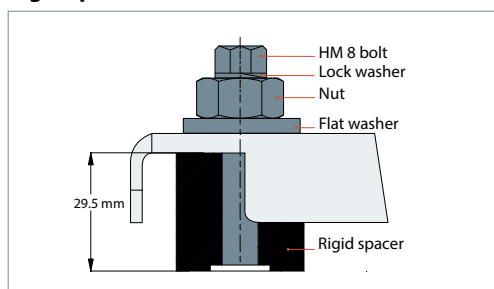

Flexible grommet

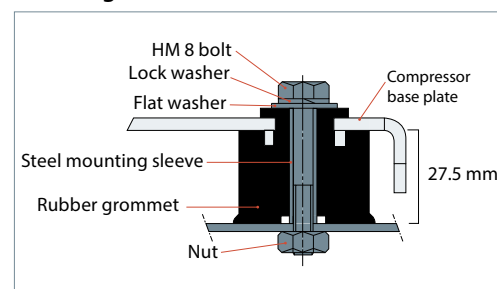

SH380 code 3

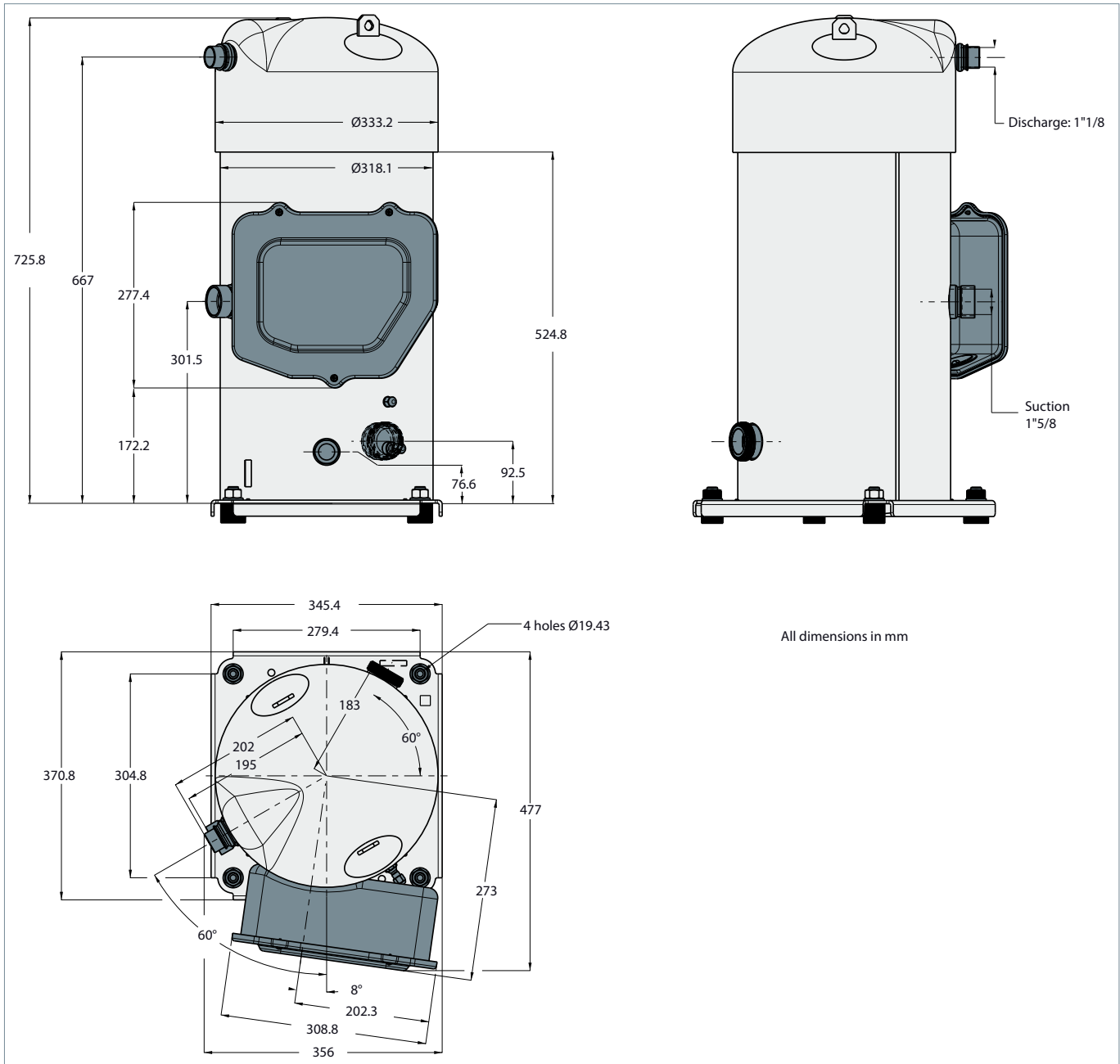

Rigid spacer

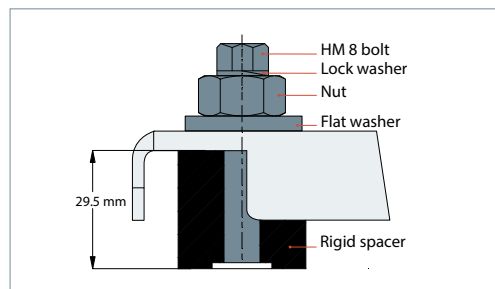

Flexible grommet

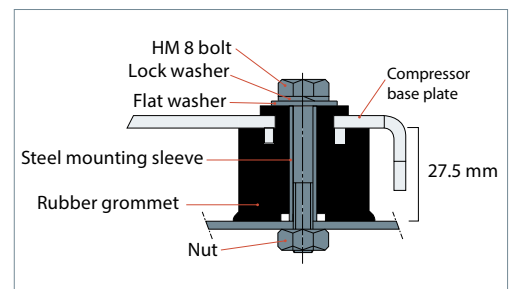

Connection details

	SH 090 - 105 - 120 - 140 - 161 - 184	SH 180 - 240 - 295 - 380 - 485
Version	AL	
Suction and discharge connections	Brazed	Brazed
Oil sight glass	Threaded	Threaded
Oil equalisation connection	rotolock 1"3/4	rotolock 2"1/4
Oil drain connection	none	1/4" flare
Low pressure gauge port (schrader)	1/4" flare	1/4" flare

Suction and discharge connections

		Brazed version
		
		Tube ODF
		Brazed
SH090	Suction	1"1/8
	Discharge	7/8"
SH105 - 120-140-161-184	Suction	1"3/8
	Discharge	7/8"
SH180-240-295-380	Suction	1" 5/8
	Discharge	1" 1/8
SH485	Suction	1"5/8
	Discharge	1"3/8

Oil sight glass

All Danfoss SH scroll compressors come equipped with a sight glass (1"1/8 - 18 UNF) which may be used to determine the amount and condition of the oil contained within the sump.

Oil equalisation connection

SH090-105-120-140-161-184: 1"3/4 rotolock connector allowing use of 1"3/4 - 7/8" or 1"3/4 - 1"1/8 sleeve.

SH180-240-295-380-485: 2"1/4 rotolock connector allowing the use of 2"1/4 - 1"3/8 or 2"1/4 - 1"5/8 sleeve.

This connection must be used to mount an oil equalisation line when two or more compressors are mounted in parallel (please refer to Danfoss SH Parallel Application Guidelines FRCC.EC.008. for details).

Oil drain connection

The oil drain connection allows oil to be removed from the sump for changing, testing, etc. The fitting contains an extension tube into the oil sump to more effectively remove the oil. The connection is a female 1/4" flare fitting incorporating a schrader valve and is mounted on SH180 - 240 - 295 - 380 - 485 models only.

Schrader

The oil fill connection and gauge port is a 1/4" male flare connector incorporating a schrader valve.

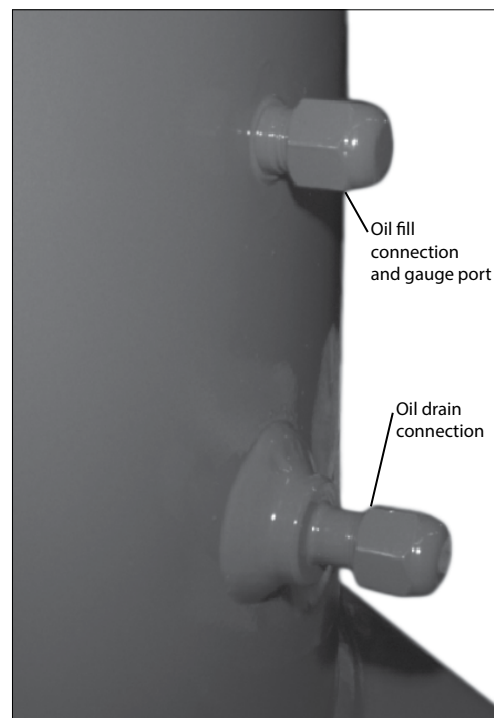

Motor voltage

Danfoss SH scroll compressors are available in five different motor voltages as listed below.

Motor voltage code	Code 3	Code 4	Code 6	Code 7	Code 9	
50 Hz	Nominal voltage	-	380-400V - 3 ph 380-415V - 3 ph*	230V - 3 ph	500V - 3 ph	-
	Voltage range	-	342-440 V 342-457V*	207-253 V	450 - 550 V	-
60 Hz	Nominal voltage	200-230V - 3 ph	460V - 3 ph	-	575 V-3 ph	380V- 3 ph
	Voltage range	180-253 V	414-506 V	-	517-632 V	342-418 V

* SH295 and 485

Wiring connections

Electrical power is connected to the compressor terminals by \varnothing 4.8 mm (3/16") screws.

The maximum tightening torque is 3 Nm. Use a 1/4" ring terminal on the power leads.

SH090-105-120-140-161
Except SH140-161 code 3

The terminal box is provided with a \varnothing 25.5 mm (ISO25) and a \varnothing 29 mm (PG21) knockouts.

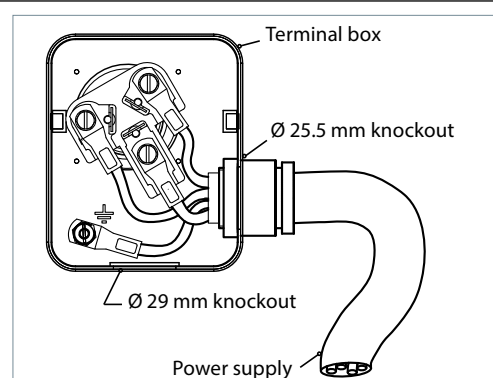

SH140&161 code 3 and SH184

The terminal box is provided with a \varnothing 40.5 mm hole (ISO40) for power supply and a \varnothing 16.5 mm knockout (ISO16).

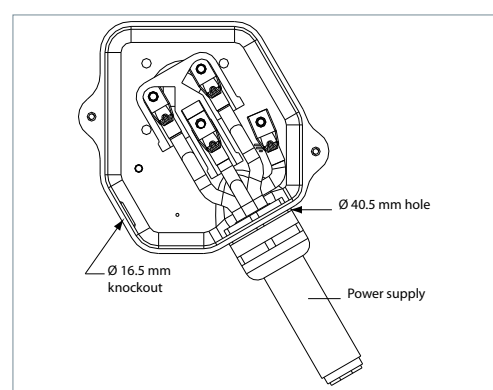

Application Guidelines

Electrical data, connections and wiring

SH180-240-295-380*-485*

Except code 3

The terminal box is provided with 2 triple knockouts and 1 single knockout for power supply and 4 double knockouts for the safety control circuit.

The 3 power supply knockouts accommodate the following diameters:

- Ø 50.8 mm (UL 1"1/2 conduit) and Ø 43.7 mm (UL 1"1/4 conduit) and Ø 34.5 mm (UL 1" conduit)
- Ø 40.5 mm (ISO40) and Ø 32.2 mm (ISO32) and Ø 25.5 mm (ISO25)
- Ø 25.5 mm (ISO25)

The 4 others knockouts are as follows:

- Ø 22.5 mm (PG16) (UL 1/2") and Ø 16.5 mm (ISO16) (x2)
- 20.7 mm (ISO20 or PG13.5) (x2)

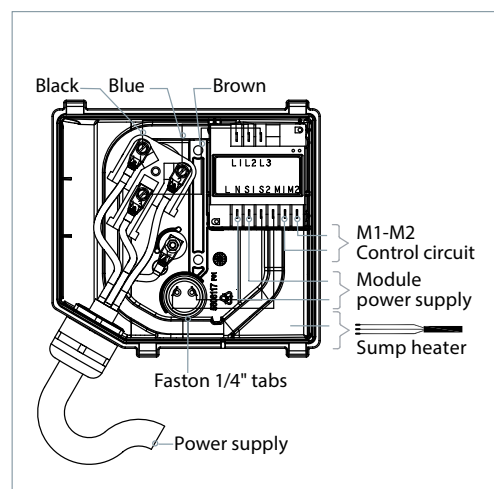

SH380 code 3

The terminal box is provided with Ø 50.5 mm (ISO50) (UL 1"1/2 conduit) hole with possible Ø 63.5 mm (ISO63) (UL 2" conduit) knockout for power supply and 2 x Ø 22.5 mm (PG16) (UL 1/2" conduit) knockouts for safety control circuit.

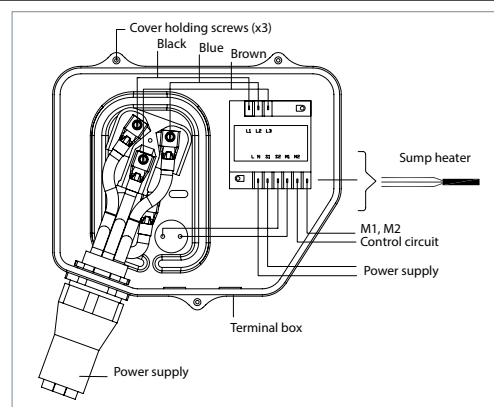

The motor protection module comes preinstalled within the terminal box. Phase sequence protection connections and thermistor connections are pre-wired. The module must be connected to a power supply of the appropriate voltage. The module terminals are 6.3-mm size Faston type.

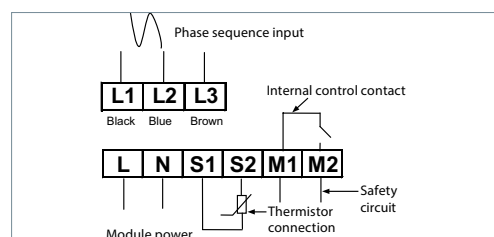

IP rating

The compressor terminal box according to IEC529 is IP54 for all models when correctly sized IP54 rated cable glands are used.

First numeral, level of protection against contact and foreign objects

5 - Dust protected

Second numeral, level of protection against water

4 - Protection against water splashing

Terminal box temperature

The temperature inside the terminal box may not exceed 70°C. Consequently, if the compressor is installed in an enclosure, precautions must be taken to avoid that the temperature around the compressor and in the terminal box would rise too much. The installation of ventilation on the enclosure panels may be necessary. If not, the

electronic protection module may not operate properly. Any compressor damage related to this will not be covered by Danfoss warranty. In the same manner, cables must be selected in a way to insure that terminal box temperature does not exceed 70°C.

Three phase electrical characteristics

Compressor model	LRA	MCC	Max. operating current	Winding resistance	
	A	A	A	Ω	
Motor voltage code 3 200-230V / 3ph / 60 Hz	SH090	203	43	38	0.39
	SH105	267	46	45	0.27
	SH120	267	61	48	0.27
	SH140	304	64	56	0.24
	SH161	315	69	64	0.22
	SH184	351	75	71	0.22
	SH180	320	78	71	0.19
	SH240	485	105	103	0.16
	SH295	560	128	112	0.13
SH380	717	170	155	0.09	
Motor voltage code 4 380-400 V / 3ph / 50 Hz * 460V / 3ph / 60hZ	SH090	98	22	19	1.47
	SH105	142	25	22	1.05
	SH120	142	29	24	1.05
	SH140	147	30	28	0.92
	SH161	158	35	31	0.83
	SH184	197	38.6	36	0.83
	SH180	170	38	34	0.8
	SH240	215	51	49	0.62
	SH295	260	62	56	0.52
SH380	320	79	72	0.42	
SH485	413	90	89	0.23	
Motor voltage code 6 230 V / 3ph / 50 Hz	SH090	157	40	32	0.5
	SH105	223	43	38	0.35
	SH120	223	51	41	0.35
	SH140	236	53	49	0.31
	SH161	236	57	53	0.31
	SH184	236	57	56	0.31
Motor voltage code 7 500 V / 3ph / 50 Hz 575 V / 3 ph / 60 Hz	SH090	84	18	14	2.34
	SH105	103	22	17	1.57
	SH120	103	24	19	1.57
	SH140	122	26	22	1.38
	SH161	136	29	24	1.32
	SH184	135	35	28	1.32
	SH180	135	30	28	1.20
	SH240	175	41	38	0.94
	SH295	210	45	44	0.82
SH380	235	60	55	0.56	
SH485	327	71	71	0.36	
Motor voltage code 9 380 V / 3ph / 60 Hz	SH090	124	26	23	1.05
	SH105	160	32	26	0.72
	SH120	160	35	29	0.72
	SH140	168	37	33	0.62
	SH161	177	41	37	0.57
	SH184	239	51	41	0.57
	SH180	210	46	44	0.52
	SH240	260	60	58	0.42
	SH295	310	72	69	0.36
SH380	360	90	85	0.24	
SH485	491	111	106	0.16	

* 380-415V/3ph/50Hz for SH295 and SH485

LRA (Locked Rotor Amp)

Locked Rotor Amp value is the higher average current as measured on mechanically blocked compressor tested under nominal voltage. The LRA value can be used as rough estimation for

the starting current. However in most cases, the real starting current will be lower. A soft starter can be applied to reduce starting current.

MCC (Maximum Continuous Current)

The MCC is the current at which the motor protection trips under maximum load and low voltage conditions. This MCC value is the maximum at which the compressor can be operated in transient conditions and out of

the application envelope. Above this value, the internal motor protection or external electronic module will cut-out the compressor to protect the motor.

Max. operating Current

The max. operating current is the current when the compressor operates at maximum load conditions and 10% below nominal voltage (+15°C evaporating temperature and +68°C condensing temperature).

Max Oper. A can be used to select cables and contactors.

In normal operation, the compressor current consumption is always less than the Max Oper. A. value.

Winding resistance

Winding resistance is the resistance between phases at 25°C (resistance value +/- 7%). Winding resistance is generally low and it requires adapted tools for precise measurement. Use a digital ohm-meter, a "4 wires" method and measure under stabilised ambient temperature. Winding resistance varies strongly with winding temperature. If the compressor is stabilised at a different value than 25°C, the measured resistance must be corrected using following formula:

$$R_{t_{amb}} = R_{25^{\circ}\text{C}} \frac{a + t_{amb}}{a + t_{25^{\circ}\text{C}}}$$

$t_{25^{\circ}\text{C}}$: reference temperature = 25°C
 t_{amb} : temperature during measurement (°C)
 $R_{25^{\circ}\text{C}}$: winding resistance at 25°C
 R_{amb} : winding resistance at t_{amb}
 Coefficient a = 234.5

Danfoss MCI soft-start controller

The inrush current for the Danfoss SH scroll compressors with motor code 4 (400V /3ph / 50Hz or 460V / 3ph / 60Hz) can be reduced using the Danfoss soft starter. MCI and MCD soft starters are designed to reduce the

starting current of 3-phase AC motors; they can reduce the inrush current by up to 40%, thereby eliminating the detrimental effects of high starting torque surges and costly demand charges from the resultant current spike.

Compressor model	Soft start reference Ambient max. 40°C	Soft start reference Ambient max. 55°C
SH090	MCI15C	MCI15C
SH105-120	MCI25C	MCI25C
SH140-161-184	MCI25C	MCI25C *
SH180	MCI50CM	MCI50CM
SH240	MCI50CM	MCI50CM *
SH295-380	MCI50CM *	MCI50CM *
SH485	MCD201-055	MCD201-055

* by-pass contactor K1 is required

Upon starting, the controller gradually increases the voltage supplied to the motor until full-line voltage has been reached.

For MCI15C, MCI25C and MCI50M, all settings such as initial torque, ramp-up time (less than 0.5 sec) and ramp-down time are preset and do not require any modification.

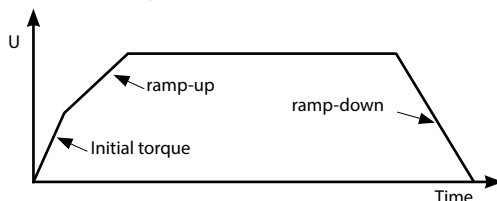

For MCD201-055, the following settings have to be adjusted to ensure a maximum inrush current reduction as well as a starting time less than 0.5 sec.

Frequency	Initial torque (%U)	Ramp-up (seconds)	Ramp down (seconds)
50 Hz	60%	2	0
60 Hz	70%	0.5	0

Input controlled soft start

When the control voltage is applied to A1 - A2, the MCI soft starter will start the motor, according to the settings of the ramp-up time and initial torque adjustments. When the control voltage is switched OFF, the motor will switch off instantaneously.

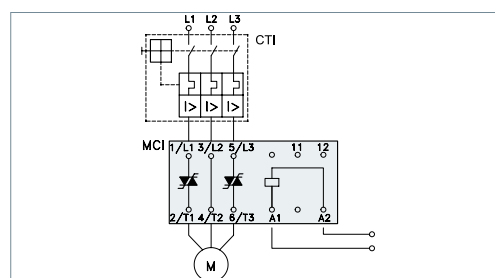

MCI with by-pass contactor

By means of the built-in auxiliary contact (23-24) the by-pass function is easily achieved, see wiring diagram beside.

No heat is generated from the MCI. As the contactor always switches in no-load condition it can be selected on the basis of the thermal current (AC-1).

13-14 contact not applicable with MCI 25C.

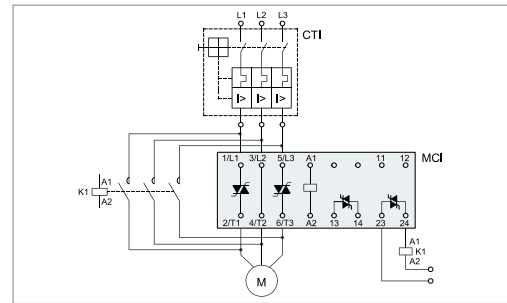

General wiring information

The wiring diagrams below are examples for a safe and reliable compressor wiring. In case an alternative wiring logic is chosen, it is imperative to respect the following rules:

When a safety switch trips, the compressor must stop immediately and must not re-start until the tripping condition is back to normal and the safety switch is closed again. This applies to the LP safety switch, the HP safety switch, the discharge gas thermostat and the motor safety thermostat.

In specific situations, such as winter start operation, an eventual LP control for pump-down cycles may be temporarily bypassed to

allow the system to build pressure. But it remains mandatory for compressor protection to apply an LP safety switch. The LP safety switch must never be bypassed.

Pressure settings for the LP and HP safety switch and pump-down listed in table from section "Low pressure".

When ever possible (ie. PLC control), it is recommended to limit the possibilities of compressor auto restart to less than 3 to 5 times during a period of 12 hours when caused by motor protection or LP safety switch tripping. This control must be managed as a manual reset device.

Suggested wiring diagrams logic

Compressor model SH 090 - 105 - 120 - 140 - 161 - 184

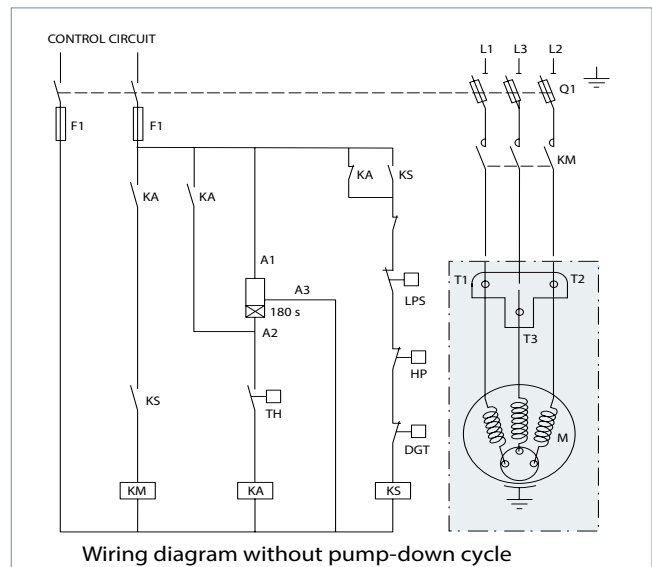
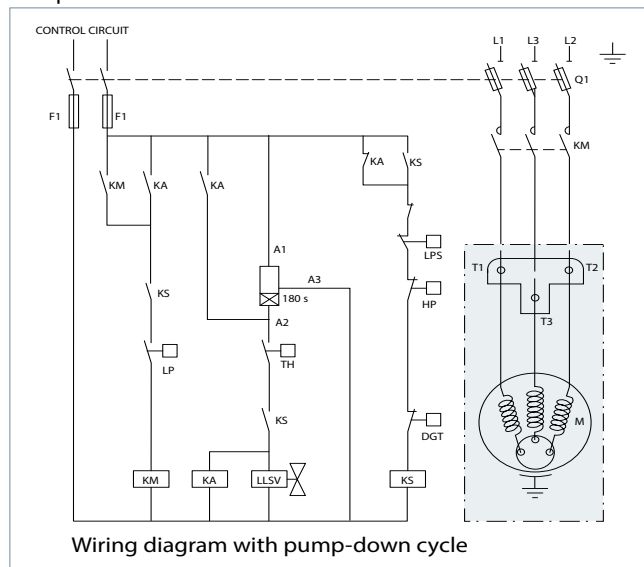

Compressor model SH180-240-295-380

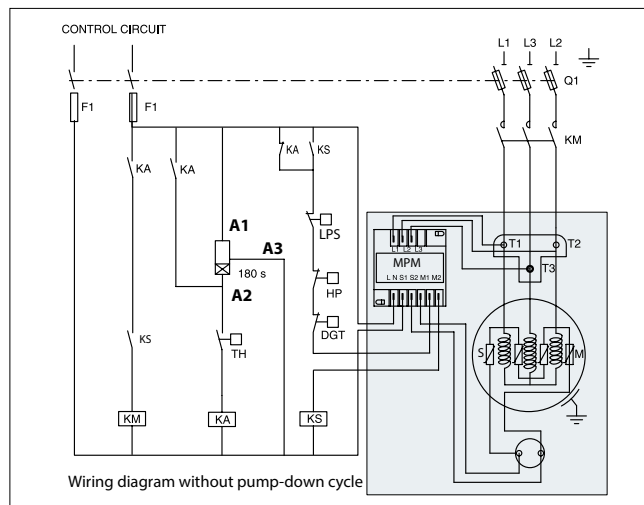
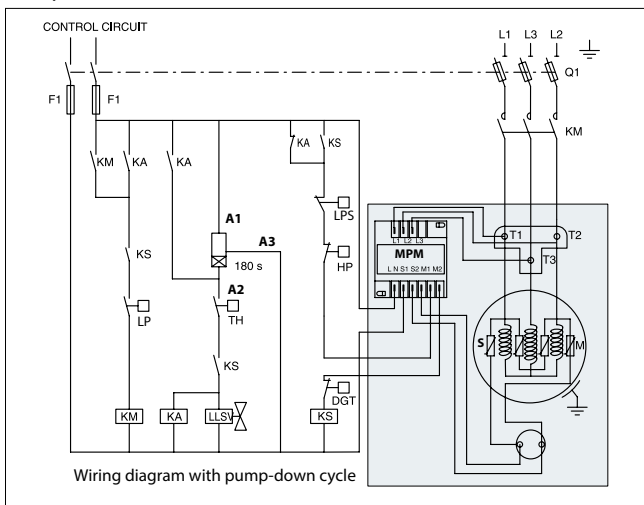

Compressor model SH485

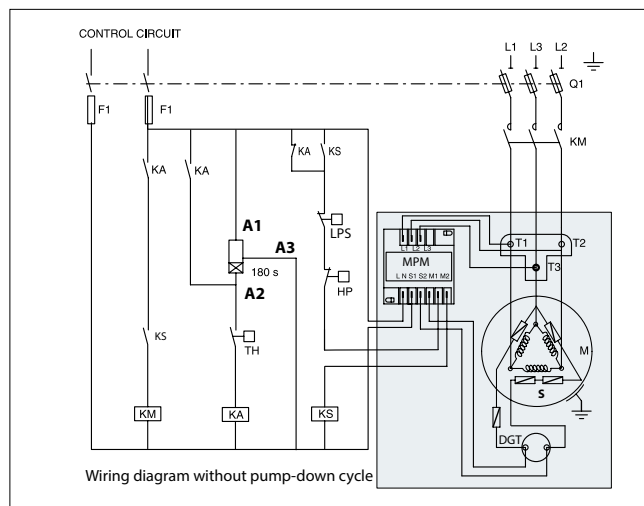
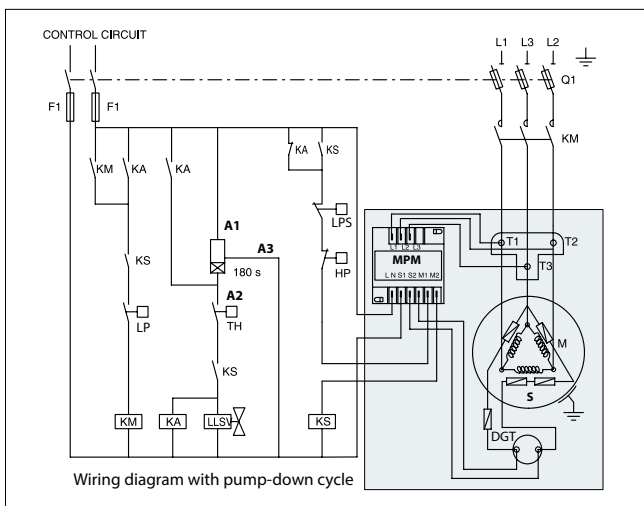

Legend

- | | | | |
|---|-------|---|------|
| Fuses | F1 | Liquid Line Solenoid valve | LLSV |
| Compressor contactor | KM | Discharge gas thermostat / thermistor | DGT |
| Control relay | KA | Fused disconnect | Q1 |
| Safety lock out relay | KS | Motor safety thermostat | thM |
| Optional short cycle timer (3 mins) | 180 s | Compressor motor | M |
| External overload protection | F2 | Motor Protection Module | MPM |
| Pump-down pressure switch | LP | Thermistor chain | S |
| High pressure safety switch | HP | Safety pressure switch | LPS |
| Control device | TH | | |

Motor protection

Compressor model	Overheating protection	Over current protection	Locked rotor protection	Phase reversal protection
SH 090 - 105 - 120 - 140- 161 - 184	<input checked="" type="checkbox"/> Internal motor protection			Internal reverse vent
SH 180	<input checked="" type="checkbox"/> Electronic module located in terminal box			Internal reverse vent
SH240 - 295 - 380-485	<input checked="" type="checkbox"/> Electronic module located in terminal box			

Compressor models SH090-105-120-140-161-184 have been provided with an internal overload motor protection to prevent against excessive current and temperature caused by overloading, low refrigerant flow or phase loss. The cutout current is the MCC value listed in section "Three phase electrical characteristics".

The protector is located in the star point of the motor and, should it be activated, will cut out all three phases. It will be reset automatically.

Compressor models SH180-240-295-380-485 are delivered with a pre installed motor protection module inside the terminal box. This device provides for efficient and reliable protection against overheating and overloading as well as phase loss/reversal.

The motor protector comprises a control module and PTC sensors embedded in the motor winding. The close contact between thermistors and windings ensures a very low level of thermal inertia.

The motor temperature is being constantly measured by a PTC thermistor loop connected on S1-S2. If any thermistor exceeds its response temperature, its resistance increases above the trip level (4,500 Ω) and the output relay then trips – i.e. contacts M1-M2 are open. After cooling to below the response temperature (resistance < 2,750 Ω), a 5-minute time delay is activated.

While not compulsory, an additional external overload is still advisable for either alarm or manual reset.

Then it must be set below MCC value (at max operating current:

- when the motor temperature is too high, then the internal protector will trip
- when the current is too high the external overload protection will trip before the internal protection therefore offering possibility of manual reset.

After this delay has elapsed, the relay is once again pulled in – i.e. contacts M1-M2 are closed. The time delay may be cancelled by means of resetting the mains (L-N -disconnect) for approximately 5 sec.

A red/green twin LED is visible on the module. A solid green LED denotes a fault free condition. A blinking red LED indicates an identifiable fault condition:

PTC overheat

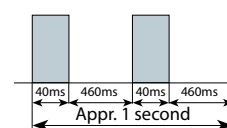

Delay timer active (after PTC over temp.)

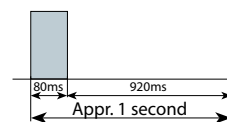

Phase sequence and reverse rotation protection

Use a phase meter to establish the phase orders and connect line phases L1, L2 and L3 to terminals T1, T2 and T3, respectively. The compressor will only operate properly in a single

direction, and the motor is wound so that if the connections are correct, the rotation will also be correct.

Compressor models SH090-105-120-140-161-184, SH180 incorporates an internal reverse vent valve which will react when the compressor is run in reverse and will allow refrigerant to circulate through a by-pass from the suction to the discharge. Although reverse rotation is not destructive for these models, it should be corrected as soon as possible. Repeated reverse rotation longer than 24hours may have negative

impact on the bearings. Reverse rotation will be obvious to the user as soon as power is turned on: the compressor will not build up pressure, the sound level will be abnormally high and power consumption will be minimal. If reverse rotation symptoms occur, shut the compressor down and connect the phases to their proper terminals. If reverse rotation is not halted, the compressor will cycle off-on the motor protection.

Compressor models SH180, 240 to 485 are delivered with an electronic module which provides protection against phase reversal and phase loss at start-up. Apply the recommended wiring diagrams from section "Suggested wiring diagram logic". The circuit should be thoroughly checked in order to determine the cause of the phase problem before re energizing the control circuit.

Should one of these parameters be incorrect, the relay would lock out (contact M1-M2 open). The red led on the module will show the following blink code:

The phase sequencing and phase loss monitoring functions are active during a 5-sec window 1 second after compressor start-up (power on L1-L2-L3).

In case of phase reverse error:

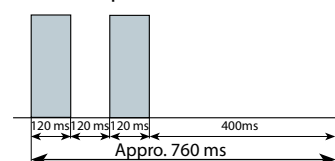

In case of phase loss error:

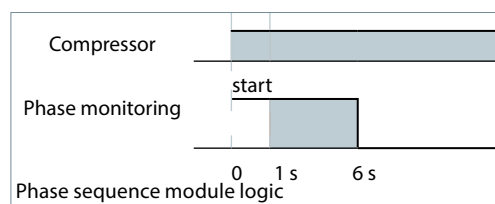
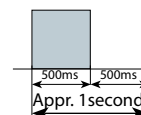

The lockout may be cancelled by resetting the power mains (disconnect L-N) for approximately 5 seconds.

Voltage imbalance

The operating voltage limits are shown in the table section "Motor voltage". The voltage applied to the motor terminals must lie within these table limits during both start-up and normal operations. The maximum allowable voltage

imbalance is 2%. Voltage imbalance causes high amperage over one or several phases, which in turn leads to overheating and possible motor damage. Voltage imbalance is given by the formula:

$$\% \text{ voltage imbalance} = \frac{|V_{avg} - V_{1-2}| + |V_{avg} - V_{1-3}| + |V_{avg} - V_{2-3}|}{2 \times V_{avg}} \times 100$$

Vavg = Mean voltage of phases 1, 2, 3.

V1-3 = Voltage between phases 1 and 3.

V1-2 = Voltage between phases 1 and 2.

V2-3 = Voltage between phases 2 and 3.



Application Guidelines

Approval and certifications

Approvals and certificates

SH scroll compressors comply with the following approvals and certificates.

Certificates are listed on the product datasheets: <http://www.danfoss.com/odsg>

CE 0062 or CE 0038 or CE0871 (European Directive)		All SH models
UL (Underwriters Laboratories)		All 60 Hz SH models
Other approvals / certificates		Contact Danfoss

Pressure Equipment Directive 97/23/EC

Products	SH090-105-120-140-161-184	SH180-240-295-485	SH380
Refrigerating fluids	Group 2	Group 2	Group 2
Category PED	II	II	III
Evaluation module	D1	D1	H
Service temperature - Ts	-35°C < Ts < 55°C	-35°C < Ts < 51°C	-35°C < Ts < 51°C
Service pressure - Ps	33.3 bar(g)	30.2 bar(g)	30.2 bar(g)
Declaration of conformity	contact Danfoss		

Low voltage directive 2006/95/EC

Products	SH090 to 485
Declaration of conformity ref. Low voltage Directive 2006/95/EC	Contact Danfoss

Machines directive 2006/42/EC

Products	SH090 to 485
Manufacturer's declaration of incorporation ref. Machines Directive 2006/42/EC	Contact Danfoss

Internal free volume

Products	Internal free volume without oil (litre)
SH090	12.4
SH105-120-140-161	14.3
SH184	14.6
SH180	31.6
SH240-295	31.0
SH380	34.3
SH485	30.1

The scroll compressor application range is influenced by several parameters which need to be monitored for a safe and reliable operation.

These parameters and the main recommendations for good practice and safety devices are explained hereunder.

- **Refrigerant and lubricants**
- **Motor supply**
- **Compressor ambient temperature**
- **Application envelope** (evaporating temperature, condensing temperature, return gas temperature)

Refrigerant and lubricants

General information

When choosing a refrigerant, different aspects must be taken into consideration:

- Legislation (now and in the future)
- Safety
- Application envelope in relation to expected running conditions
- Compressor capacity and efficiency

- Compressor manufacturer recommendations and Guidelines
- Additional points could influence the final choice:
- Environmental considerations
 - Standardisation of refrigerants and lubricants
 - Refrigerant cost
 - Refrigerant availability

Danfoss Commercial Compressors, along with the whole refrigeration and air conditioning industry, shares today's concern about the environmental issues that are ozone depletion, global warming and overall energy consumption. Usual HCFCs refrigerant fluids such as R22 are known to be implicated in these harmful phenomena, especially ozone depletion due to their chlorinated content. These substances are scheduled to be phased-out from production

and use in coming years, in accordance with the international Montreal Protocol (1984). As a result, new chlorine-free molecules have been recently developed and are now ready to replace former fluids. Among those refrigerants, the HFC blend R410A is admitted by a great majority of manufacturers to be the most promising in terms of environmental impact, stability and efficiency, and is already seen as the R22 replacement.

	Refrigerant	R22	R407C	R410A
Chemical properties	Chlorine content	yes	no	no
	Zeotropic	pure refrigerant	zeotropic mixture	near azeotropic mixture
	Composition	R22	R32/R125/R134a	R32/R125
Environmental impact	ODP	0.05	0	0
	GWP	1500	1526	1725
Thermodynamic properties	Vapour pressure (bar) at 25°C	10.4	11.9	16.5
	Cooling capacity of liquid (kJ/kg.K) at 25°C	1.24	1.54	1.84
	Cooling capacity of vapor (kJ/kg.K) at 1 atm, 25 °C	0.657	0.829	0.833
	Temperature glide (°C)	0	7.4	<0.2

R410A

SH compressors are to be used with R410A refrigerant, with polyolester oil.

- R410A's superior thermodynamical properties compared to R22 and R407C refrigerants allow for today's massive – and necessary – switch to high efficiency systems.
- Zero Ozone Depletion Potential (ODP): R410A does not harm the ozone layer.
- Global warming potential (GWP): R410A shows a relatively high warming potential. However, the GWP index denotes direct warming effect, which is relevant only in case of release to the atmosphere. A more accurate index is T.E.W.I., for Total Equivalent Warming Impact, which takes into account indirect contributions due to running energy costs.

- Because of the higher system efficiency it allows to achieve, R410A is in this regard the best refrigerant.
- As a near-azeotropic mixture, refrigerant R410A behaves like an homogeneous substance, whereas other zeotropic mixtures such as R407C and other blends suffer a temperature glide during phase change that lessens thermal efficiency and makes them difficult to transfer from a container to another.
- Reduced refrigerant mass flow, permitted by a higher heat capacity, induce a lower sound level of the installation as well as more compact and lighter systems.

Application Guidelines

Operating conditions

POE oil	Polyolester oil (POE) is miscible with HFC's (while mineral oil is not), but has to be evaluated regarding lubrication ability in compressors. POE oil has better thermal stability than refrigerant mineral oil.	POE is more hygroscopic and also holds moisture more tight than mineral oil. It also chemically reacts with water leading to acid and alcohol formation.
Motor supply	SH scroll compressors can be operated at nominal voltages as indicated section "Motor voltage". Under-voltage and over-voltage	operation is allowed within the indicated voltage ranges. In case of risk of under-voltage operation, special attention must be paid to current draw.
Compressor ambient temperature	SH compressors can be applied from -35°C to 55°C ambient temperature for SH090-105-120-140-161-184 and 51°C ambient temperature for SH180-240-295-380-485. The compressors are	designed as 100% suction gas cooled without need for additional fan cooling. Ambient temperature has very little effect on the compressor performance.
High ambient temperature	In case of enclosed fitting and high ambient temperature, it is recommended to check the temperature of power wires and conformity to their insulation specification.	In case of safe tripping by the internal compressor overload protection, the compressor must cool down to about 60°C before the overload will reset. A high ambient temperature can strongly delay this cool-down process.
Low ambient temperature	Although the compressor itself can withstand low ambient temperature, the system may require specific design features to ensure safe	and reliable operation. See section 'Specific application recommendations'.

Application envelope

The operating envelope for SH scroll compressors is given in the figure below, where the condensing and evaporating temperatures represent the range for steady-state operation. Under transient conditions, such as start-up and defrost, the compressor may operate outside this envelope for short periods.

- Maximum discharge gas temperature: +135°C,
- A suction superheat below 5 K is not recommended due to the risk of liquid flood back,
- Maximum superheat of 30 K,
- Minimum and maximum evaporating and condensing temperatures as per the operating envelopes.

The operating limits serve to define the envelope within which reliable operations of the compressor are guaranteed:

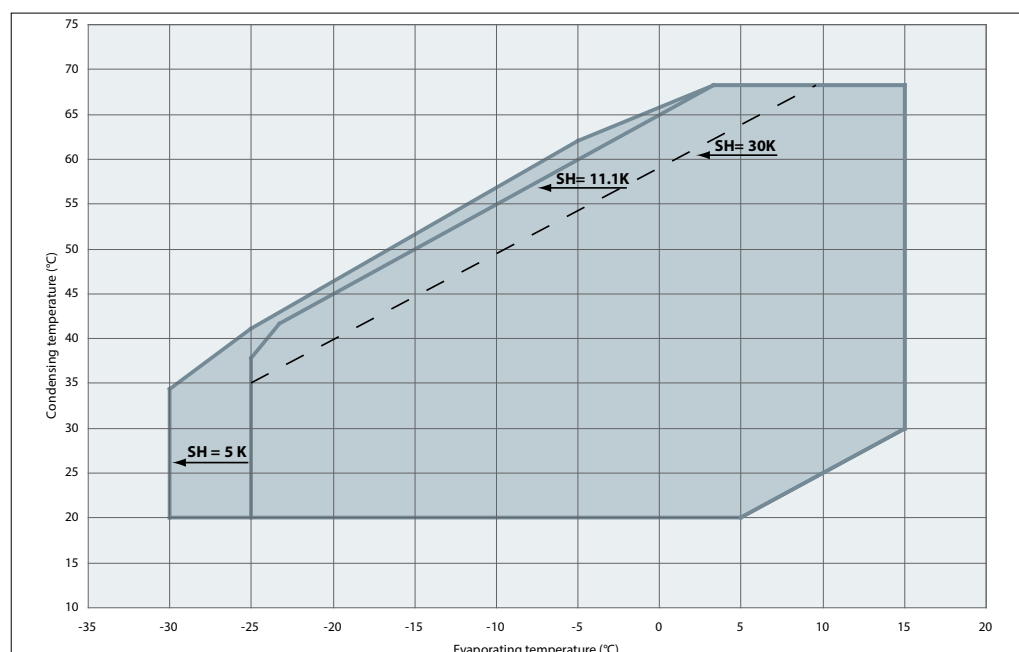

Discharge temperature protection

The discharge gas temperature must not exceed 135°C.

SH485 includes a PTC sensor located in the fixed scroll and wired in series with the motor PTC thermistor chain. Excessive discharge temperature will result in electronic module output relay to trip.

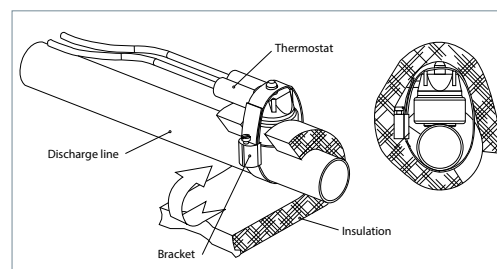

For SH090 to 380, DGT protection is required if the high and low pressure switch settings do not protect the compressor against operations beyond its specific application envelope. Please refer to the examples below, which illustrate where DGT protection is required (Ex.1) and where it is not (Ex.2).

The discharge gas thermostat accessory kit (code 7750009) includes all components required for installation as shown above. The thermostat must be attached to the discharge line within 150 mm from the compressor discharge port and must be thermally insulated and tightly fixed on the pipe.

A discharge gas temperature protection device must be installed on all heat pumps. In reversible air-to-air and air-to-water heat pumps the discharge temperature must be monitored during development test by the equipment manufacturer.

The DGT should be set to open at a discharge gas temperature of 135°C.

⚠ The compressor must not be allowed to cycle on the discharge gas thermostat. Continuous operations beyond the compressor's operating range will cause serious damage to the compressor!

Example 1 (R410A, SH = 11 K)
 LP switch setting:
 LP1 = 3.3 bar (g) (-15.5°C)
 HP switch setting:
 HP1 = 38 bar (g) (62°C)
 Risk of operation beyond the application envelope.
 DGT protection required.

Example 2 (R410A, SH = 11 K)
 LP switch setting:
 LP2 = 4.6 bar (g) (-10.5°C)
 HP switch setting:
 HP2 = 31 bar (g) (52°C)
 No risk of operation beyond the application envelope.
 No DGT protection required.

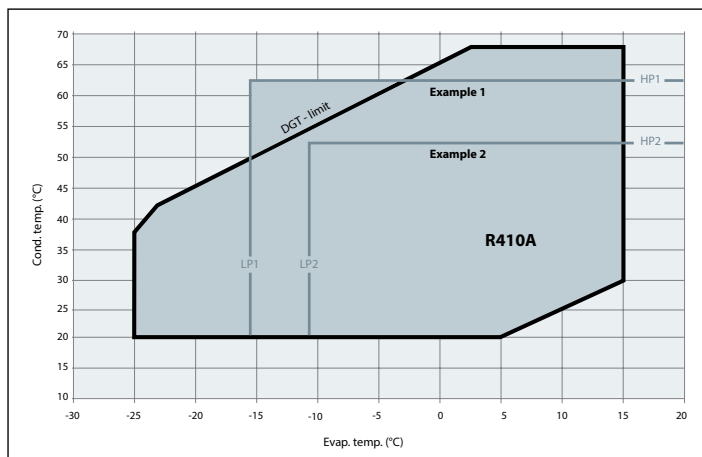

High and low pressure protection

High pressure

A high-pressure (HP) safety switch is required to shut down the compressor should the discharge pressure exceed the values shown in the table section "System pressure test". The high-pressure switch can be set to lower values depending on the application and ambient conditions. The HP

switch must either be placed in a lockout circuit or consist of a manual reset device to prevent cycling around the high-pressure limit. If a discharge valve is used, the HP switch must be connected to the service valve gauge port, which must not be isolated.

Application Guidelines Operating conditions

Internal pressure relief valve The SH380 and SH485 incorporate an internal relief valve set to open between the internal high and low pressure sides of the compressor when the pressure differential between the discharge and suction pressures surpasses 42.4 to 49 bar.

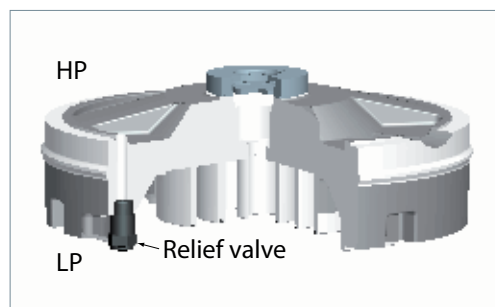

This safety feature prevents the compressor from developing dangerously high pressures should the high pressure cut-out, for whatever reason, fail to shut down the compressor.

Low pressure

A low-pressure (LP) safety switch must be used. Deep vacuum operations of a scroll compressor can cause internal electrical arcing and scroll instability. Danfoss SH scroll compressors exhibit high volumetric efficiency and may draw very low vacuum levels, which could induce such a problem. The minimum low-pressure safety switch (loss-of-charge safety switch) setting is

given in the following table. For systems without pump-down, the LP safety switch must either be a manual lockout device or an automatic switch wired into an electrical lockout circuit. The LP switch tolerance must not allow for vacuum operations of the compressor. LP switch settings for pump-down cycles with automatic reset are also listed in the table below.

Pressure settings		R410A
Working pressure range high side	bar (g)	13.5 - 44.7
Working pressure range low side	bar (g)	1.7 - 11.6
Maximum high pressure safety switch setting	bar (g)	45
Minimum low pressure safety switch setting *	bar (g)	1.5
Minimum low pressure pump-down switch setting **	bar (g)	1.7

* LP safety switch shall never be bypassed and shall have no time delay.

** Recommended pump-down switch settings: 1.5 bar below nominal evap. pressure with minimum of 1.7 bar(g)

Note that these two different low pressure switches also require different settings. The low pressure pump down switch setting must always be within the operating envelope, for example 1.7 bar for R410A. The compressor can be operated full time under such condition.

The minimum low pressure safety switch setting may be outside the normal operating envelope and should only be reached in exceptional (emergency) situations, for example 1.5 bar for R410A.

Cycle rate limit

Danfoss recommends a restart delay timer to limit compressor cycling. The timer prevents reverse compressor rotation, which may occur during brief power interruptions.

There must be no more than 12 starts per hour, a number higher than 12 reduces the service life of the motor-compressor unit. A three-minute (180-sec) time out is recommended.

The system must be designed in a way that guarantees a minimum compressor running time of 2 minutes so as to provide for sufficient motor cooling after start-up along with proper oil return. Note that the oil return may vary since it depends upon system design.

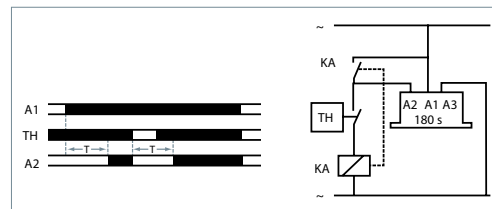

General

Successful application of scroll compressors is dependent on careful selection of the compressor for the application. If the compressor is not correct for the system, it will operate

beyond the limits given in this manual. Poor performance, reduced reliability, or both may result.

Essential piping design recommendations

The working pressure in systems with R410A is about 60% higher than in systems with R22 or R407C. Consequently, all system components and piping must be designed for this higher pressure level.

compared to R22 / R407C systems. Take care not to create too high pressure drops since in R410A systems the negative impact of high pressure drops on the system efficiency is stronger than in R22/R407C systems.

Proper piping practices should be employed to ensure adequate oil return, even under minimum load conditions with special consideration given to the size and slope of the tubing coming from the evaporator. Tubing returns from the evaporator should be designed so as not to trap oil and to prevent oil and refrigerant migration back to the compressor during off-cycles.

Piping should be designed with adequate three-dimensional flexibility. It should not be in contact with the surrounding structure, unless a proper tubing mount has been installed. This protection proves necessary to avoid excess vibration, which can ultimately result in connection or tube failure due to fatigue or wear from abrasion. Aside from tubing and connection damage, excess vibration may be transmitted to the surrounding structure and generate an unacceptable noise level within that structure as well. For more information on noise and vibration, see the section on: "Sound and vibration management".

In systems with R410A, the refrigerant mass flow will be lower compared to R22/R407C systems. To maintain acceptable pressure drops and acceptable minimum gas velocities, the refrigerant piping must be reduced in size

Suction lines

If the evaporator lies above the compressor, as is often the case in split or remote condenser systems, the addition of a pump-down cycle is strongly recommended. If a pump-down cycle were to be omitted, the suction line must have a loop at the evaporator outlet to prevent refrigerant from draining into the compressor during off-cycles.

If the evaporator were situated below the compressor, the suction riser must be trapped so as to prevent liquid refrigerant from collecting at the outlet of the evaporator while the system is idle, which would mislead the expansion valve's sensor (thermal bulb) at start-up.

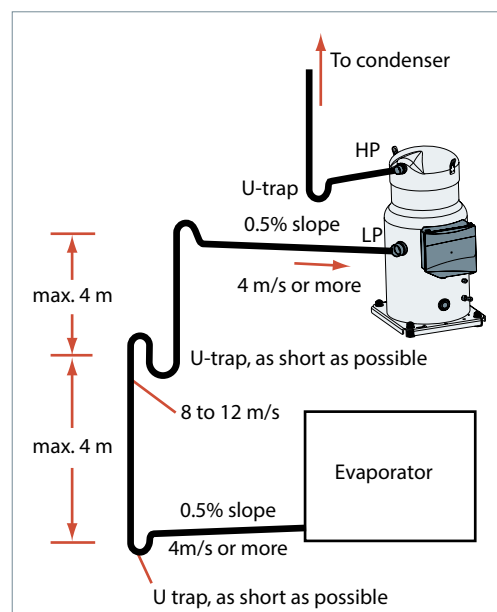

Discharge lines

When the condenser is mounted at a higher position than the compressor, a suitably sized "U"-shaped trap close to the compressor is necessary to prevent oil leaving the compressor from draining back to the discharge side of the compressor during off cycle. The upper loop also helps avoid condensed liquid refrigerant from draining back to the compressor when stopped.

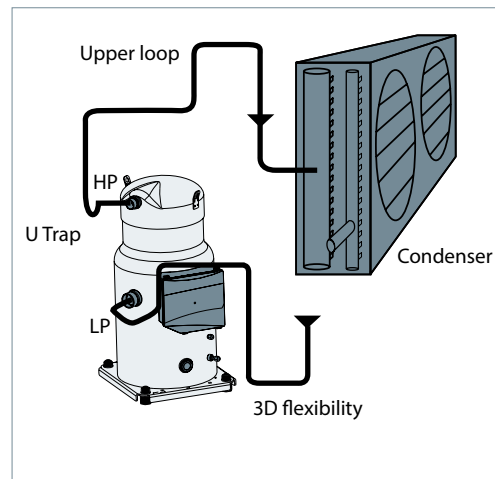
Heat exchangers

To obtain optimum efficiency of the complete refrigerant system, optimised R410A heat exchangers must be used. R410A refrigerant has good heat transfer properties: it is worthwhile designing specific heat exchangers to gain in size and efficiency.

An evaporator with optimised R410A distributor and circuit will give correct superheat at outlet and optimal use of the exchange surface. This is critical for plate evaporators that have generally a shorter circuit and a lower volume than shell and tubes and air cooled coils.

For all evaporator types a special care is required for superheat control leaving the evaporator and oil return.

A sub-cooler circuit in the condenser that creates high sub cooling will increase efficiency at high condensing pressure. In R410A systems the positive effect of sub cooling on system efficiency will be significantly larger than in R22/R407C systems.

Furthermore, for good operation of the expansion device and to maintain good efficiency in the evaporator it is important to have an appropriate sub cooling. Without adequate sub cooling, flash gas will be formed at the expansion device resulting in a high degree of vapour at the expansion device inlet leading to low efficiency.

Refrigerant charge limit

Danfoss SH compressors can tolerate liquid refrigerant up to a certain extent without major problems. However, excessive liquid refrigerant in the compressor is always unfavourable for service life. Besides, the installation cooling capacity may be reduced because of the evaporation taking place in the compressor and/or the suction line instead of the evaporator. System design must be such that the amount of liquid refrigerant in the compressor is limited. In this respect, follow the guidelines given in the section "Essential piping design recommendations" in priority.

Use the tables below to quickly evaluate the required compressor protection in relation with the system charge and the application.

Model	Refrigerant charge limit (kg)
SH090	5.9
SH105-120-140-161-184	7.9
SH180-240-295	13.5
SH380	14.5
SH485	17

Application Guidelines System design recommendations

	BELOW charge limit	ABOVE charge limit
Cooling only systems, Packaged units	<input checked="" type="checkbox"/> No test or additional safeties required	REQ Refrigerant migration and flood back test REQ Sump heater
Cooling only systems with remote condenser and split system units	REC Refrigerant migration and flood back test REC Sump heater	REQ Refrigerant migration and flood back test REQ Sump heater REC Liquid receiver (in association with LLSV and pump down)
Reversible heat pump system	REQ Specific tests for repetitive flood back REQ Sump heater REQ Defrost test	For more details, refer to section "Reversible heat pump system"

No test or additional safeties required
 REC Recommended **REQ** Required

Note: for special conditions such as low ambient temperature, low refrigerant load or brazed plate heat exchangers please refer to corresponding sections.

More detailed information can be found in the paragraphs hereafter.
 Please contact Danfoss Technical Support for any deviation from these guidelines.

Off-cycle migration

Off-cycle refrigerant migration is likely to occur when the compressor is located at the coldest part of the installation, when the system uses a bleed-type expansion device, or if liquid is allowed to migrate from the evaporator into the compressor sump by gravity. If too much liquid refrigerant accumulates in the sump, it will saturate the oil and lead to a flooded start. When the compressor starts running again, the refrigerant evaporates abruptly under the sudden decrease of the bottom shell pressure, causing the oil to foam. In extreme situations, this might result in liquid slugging (liquid entering the scroll elements), which must be avoided as it causes irreversible damage to the compressor.

Danfoss SH scroll compressors can tolerate occasional flooded starts as long as the total system charge does not exceed the maximum compressor refrigerant charge.

A suitable test to evaluate the risk of off-cycle migration is the following:

Stabilise the non running system at 5°C ambient temperature,

Raise the ambient temperature to 20°C and keep it for 10 minutes,

Start the compressor and monitor sump temperature, sight glass indication and sound level.

The presence of liquid in the crankcase can be easily detected by checking the sump level through the oil sight glass. Foam in the oil sump indicates a flooded start.

A noisy start, oil loss from the sump and sump cool down are indications for migration. Depending on the amount of migration graduate measures shall be taken:

- **Sump heater**
- **Liquid line solenoid valve**
- **Pump down cycle**

Sump heater

The surface sump heaters are designed to protect the compressor against off-cycle migration of refrigerant.

When the compressor is idle, the oil temperature in the sump of the compressor must be maintained at no lower than 10 K above the saturation temperature of the refrigerant on the low-pressure side. This requirement ensures that the liquid refrigerant is not accumulating in the sump. A sump heater is only effective if capable of sustaining this level of temperature difference. Tests must be conducted to ensure that the appropriate oil temperature is maintained under all ambient conditions (temperature and wind). Note that below -5°C ambient temperature and a wind speed of above 5m/second, we recommend that the heaters be thermally insulated in order to limit the surrounding energy losses.

Since the total system charge may be undefined, a sump heater is recommended on all stand-alone compressors and split systems. In addition, any system containing a refrigerant charge in excess of the maximum recommended system charge for compressors requires a sump heater. A sump heater is also required on all reversible cycle applications.

At initial start-up or after power shortage, it is recommended to energize surface sump heater to remove refrigerant 6 hours in advance. A quicker start-up is possible by "jogging" the compressor to evacuate refrigerant in the compressor. Start the compressor for 1 second, then wait for 1 to 2 minutes. After 3 or 4 jogs the compressor can be started. This operation must be repeated for each compressor individually:

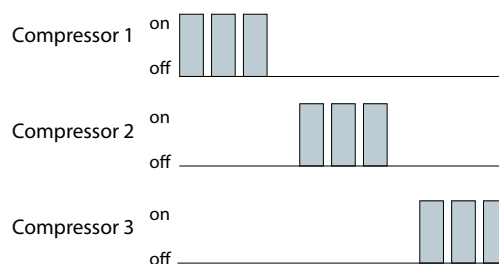

The heater must be energized whenever the compressor is off to avoid liquid refrigerant entering the compressor.

Provide separate electrical supply for the heaters so that they remain energized even when the machine is out of service (e.g. seasonal shutdown).

Surface sump heater accessories are available from Danfoss (see section "Accessories").

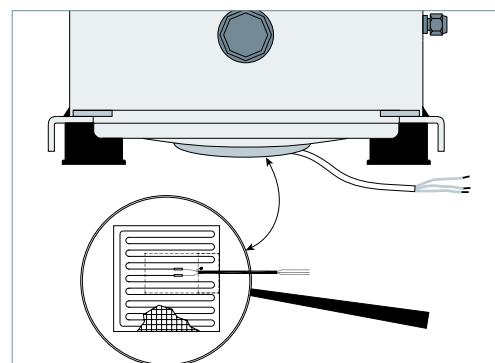
Liquid line solenoid valve (LLSV)

A LLSV may be used to isolate the liquid charge on the condenser side, thereby preventing against charge transfer or excessive migration to the compressor during off-cycles. The quantity of

refrigerant on the low-pressure side of the system can be further reduced by using a pump-down cycle in association with the LLSV.

Pump-down cycle

A pump-down cycle represents one of the most effective ways to protect against the off-cycle migration of liquid refrigerant. Once the system has reached its set point and is about to shut off, the LLSV on the condenser outlet closes. The compressor then pumps the majority of the refrigerant charge into the condenser and receiver before the system stops on the low pressure pump-down switch. This step reduces the amount of charge on the low side in order to prevent off-cycle migration. The recommended low-pressure pump-down switch setting is 1.5

bar below the nominal evaporating pressure. It shall not be set lower than 2.3 bar(g). For suggested wiring diagrams, please see section "Suggested wiring diagrams logic".

In certain conditions, the discharge valve in the SH090 - 105 - 120 - 140 - 161 - 184 compressor may not completely seal and result in compressor restarts during pump down applications. An external, non-bleeding check valve may need to be installed.

Tests for pump down cycle approval:

- As the pump-down switch setting is inside the application envelope, tests should be carried out to check unexpected cut-out during transient conditions (i.e. defrost – cold starting). When unwanted cut-outs occur, the low pressure pump-down switch can be delayed. In this case a low pressure safety switch without any delay timer is mandatory.
- While the thermostat is off, the number of pressure switch resets should be limited to avoid short cycling of the compressor. Use dedicated wiring and an additional relay which allows for one shot pump-down.

The pump-down allows to store all the refrigerant in the high pressure side circuit. On unitary or close-coupled systems, where the system refrigerant charge is expected to be both correct and definable the entire system charge may be stored in the condenser during pump-down if all components have been properly sized.

Other application needs a liquid receiver to store the refrigerant.

Receiver dimensioning requires special attention. The receiver shall be large enough to contain part of the system refrigerant charge but it shall not be dimensioned too large. A large receiver easily leads to refrigerant overcharging during maintenance operation.

Liquid flood back

During normal operation, refrigerant enters the compressor as a superheated vapour. Liquid flood back occurs when a part of the refrigerant entering the compressor is still in liquid state.

Danfoss SH scroll compressors can tolerate occasional liquid flood back. However, system

design must be such that repeated and excessive flood back is not possible.

A continuous liquid flood back will cause oil dilution and, in extreme situations, lead to lack of lubrication and high rate of oil leaving the compressor.

Liquid flood back test - Repetitive liquid flood back testing must be carried out under expansion valve threshold operating conditions: a high pressure ratio and minimum evaporator load, along with the measurement of suction superheat, oil sump temperature and discharge gas temperature.

During operations, liquid flood back may be detected by measuring either the oil sump temperature or the discharge gas temperature. If at any time during operations, the oil sump temperature drops to within 10K or less above

the saturated suction temperature, or should the discharge gas temperature be less than 35K above the saturated discharge temperature, this indicates liquid flood back.

Continuous liquid flood back can occur with a wrong dimensioning, a wrong setting or malfunction of the expansion device or in case of evaporator fan failure or blocked air filters.

A suction accumulator providing additional protection as explained hereunder can be used to solve light continuous liquid flood back.

Suction accumulator: a suction accumulator offers protection against refrigerant flood back at start-up, during operations or defrosting by trapping the liquid refrigerant upstream from the compressor. The suction accumulator also protects against off-cycle migration by providing additional internal free volume to the low side of the system.

A suction accumulator must be carefully dimensioned, taking into account the refrigerant charge as well as the gas velocity in the suction line.

The accumulator should not be sized for less than 50 % of the total system charge. Tests must be conducted to determine the actual refrigerant holding capacity needed for the application.

Depending on the operating conditions it may happen that the recommended connections of the accumulator are one size smaller than the suction line.

Low ambient application
Low ambient start-up

Under cold ambient conditions (<0°C), upon start-up the pressure in the condenser may be so low that a sufficient pressure differential across the expansion device cannot be developed to properly feed the evaporator.

As a result, the compressor may go into a deep vacuum, which can lead to compressor failure due to internal arcing and instability in the scroll wraps. Under no circumstances should the compressor be allowed to operate under vacuum. The low-pressure control must be set in accordance with the table section "Low pressure"

in order to prevent this from happening.

Early feeding of the evaporator and management of the discharge pressure could help to attenuate these effects.

Low pressure differentials can also cause the expansion device to "hunt" erratically, which might cause surging conditions within the evaporator, with liquid spillover into the compressor. This effect is most pronounced during low load conditions, which frequently occur during low ambient conditions.

Low ambient operations

The Danfoss SH scroll compressor requires a minimum pressure differential of 6 to 7 bar between the suction and discharge pressures to force the orbiting scroll down against the oil film on the thrust bearing. Anything less than this differential and the orbiting scroll can lift up, causing a metal-to-metal contact. It is therefore necessary to maintain sufficient discharge pressure in order to ensure this pressure differential. Care should be taken during low ambient operations when heat removal from air-cooled condensers is greatest and head pressure control may be required for low ambient temperature applications. Operation under low pressure differential may be observed by a significant increase in the sound power level generated by the compressor.

It is recommended that the unit be tested and monitored at minimum load and low ambient conditions as well. The following considerations should be taken into account to ensure proper system operating characteristics.

Expansion device: The expansion device should be sized to ensure proper control of the refrigerant flow into the evaporator. An oversized valve may result in erratic control. This consideration is especially important in manifolded units where low load conditions may require the frequent cycling of compressors. This can lead to liquid refrigerant entering the compressor if the expansion valve does not provide stable refrigerant super-heat control under varying loads.

The superheat setting of the expansion device should be sufficient to ensure proper superheat

levels during low loading periods. A minimum of 5 K stable superheat is required.

Head pressure control under low ambient conditions: Several possible solutions are available to prevent the risk of compressor to vacuum and low pressure differential between the suction and discharge pressures.

In air-cooled machines, cycling the fans with a head pressure controller will ensure that the fans remain off until the condensing pressure has reached a satisfactory level. Variable speed fans can also be used to control the condensing pressure. In water-cooled units, the same can be performed using a water regulator valve that is also operated by head pressure, thereby ensuring that the water valve does not open until the condensing pressure reaches a satisfactory level.

The minimum condensing pressure must be set at the minimum saturated condensing temperature shown in the application envelopes.

Under very low ambient conditions, in which testing has revealed that the above procedures might not ensure satisfactory condensing and suction pressures, the use of a head pressure control valve is recommended. Note: This solution requires extra refrigerant charge, which can introduce other problems. A non-return valve in the discharge line is recommended and special care should be taken when designing the discharge line.

For further information, please contact Danfoss.

Application Guidelines
Specific application recommendations
Sump heaters

Sump heaters are strongly recommended on all systems where the compressor is exposed to low ambient temperatures, especially split and remote condenser installations. The sump heater

will minimize refrigerant migration caused by the large temperature gradient between the compressor and the remainder of the system, please refer to section "Accessories".

Low load operation

The compressors should be run for a minimum period in order to ensure that the oil has sufficient time to properly return to the

compressor sumps and that the motor has sufficient time to cool under conditions of lowest refrigerant mass flows.

Brazed plate heat exchangers

A brazed plate heat exchanger needs very little internal volume to satisfy the set of heat transfer requirements. Consequently, the heat exchanger offers very little internal volume for the compressor to draw vapour from on the suction side. The compressor can then quickly enter into a vacuum condition. It is therefore important that the expansion device is sized correctly and that a sufficient pressure differential across the expansion device is available to ensure adequate refrigerant feed into the evaporator. This aspect is of special concern when operating the unit under low ambient and load conditions. For further information on these conditions, please refer to the previous sections.

Due to the small volume of the brazed plate heat exchanger, no pump-down cycle is normally required. The suction line running from the heat exchanger to the compressor must be trapped to avoid refrigerant migration to the compressor.

When using a brazed plate condenser heat exchanger, a sufficient free volume for the discharge gas to accumulate is required in order to avoid excess pressure build-up. At least one meter of discharge line is necessary to generate this volume. To help reduce the gas volume immediately after start-up even further, the supply of cooling water to the heat exchanger may be opened before the compressor starts up so as to remove superheat and condense the incoming discharge gas more quickly.

Electronic expansion valve

The use of an electronic expansion valve requires a specific compressor start / stop control.

A specific compressor start sequence control has to be set when an electronic expansion valve (EXV) is used. The sequence must be adjusted according to the EXV step motor speed to allow time for the EXV to open before the compressor starts to avoid running under vacuum conditions.

The EXV should be closed at compressor stop not to let refrigerant in liquid phase entering the

compressor. Ensure that the EXV closes when the supply voltage to the controller is interrupted (ie power cut off) by the use of a battery back up.

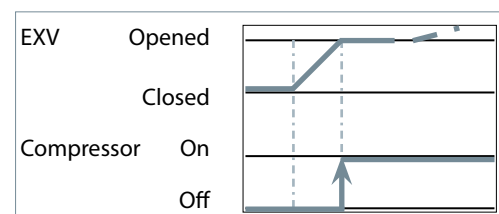
Reversible heat pump systems

Transients are likely to occur in reversible heat pump systems, i.e. a changeover cycle from cooling to heating, defrost or low-load short cycles. These transient modes of operation may lead to liquid refrigerant carry-over (or flood back) or excessively wet refrigerant return conditions. As such, reversible cycle applications require specific precautions for ensuring a long compressor life and satisfactory operating characteristics. Regardless of the refrigerant

charge in the system, specific tests for repetitive flood back are required to confirm whether or not a suction accumulator needs to be installed.

The following considerations cover the most important issues when dealing with common applications. Each application design however should be thoroughly tested to ensure acceptable operating characteristics.

Application Guidelines
Specific application recommendations
Sump heaters

Sump heaters are mandatory on reversible cycle applications given the high probability of liquid migration back to the compressor sump

during off-cycles due to the outdoor location of most units and operations during low ambient conditions.

Discharge temperature thermostat

Heat pumps frequently utilize high condensing temperatures in order to achieve a sufficient temperature rise in the medium being heated. At the same time, they often require low evaporating pressures to obtain sufficient temperature differentials between the evaporator and the outside temperature. This situation may result in high discharge temperature; as such, it is mandatory that a discharge gas thermostat be installed on the discharge line to protect

the compressor from excessive temperatures. Operating the compressor at too high discharge temperatures can result in mechanical damage to the compressor as well as thermal degradation of the compressor lubricating oil and a lack of sufficient lubrication. The discharge gas thermostat should be set to shut down the compressor in the event discharge gas rises above 135°C.

Discharge line, reversing valve, solenoid valves

The Danfoss SH scroll compressor is a high volumetric machine and, as such, can rapidly build up pressure in the discharge line if gas in the line becomes obstructed even for a very short period of time which situation may occur with slow-acting reversing valves in heat pumps. Discharge pressures exceeding the operating envelope may result in nuisance high-pressure switch cutouts and place excess strain on both the bearings and motor.

position. At the same time, it is important that the selection and sizing of the reversing or 4-way valve ensure that the valve switches quickly enough to prevent against too high discharge pressure and nuisance high-pressure cutouts.

To prevent such occurrences, it is important that a 1-meter minimum discharge line length be allowed between the compressor discharge port and the reversing valve or any other restriction. This gives sufficient free volume for the discharge gas to collect and to reduce the pressure peak during the time it takes for the valve to change

Check with the valve manufacturer for optimal sizing and recommended mounting positions.

In applications with heat recovery or condenser partialisation, servo piloted solenoid valve has to be properly sized or associated with a second small valve in parallel, in order to avoid quick discharge pressure drops when opening. This phenomenon could lead to hammering effects and create constraints on the non return valve integrated in discharge fitting (SH180 to 485).

Defrost and reverse cycle

The Danfoss SH scroll compressor has the ability to withstand a certain amount of liquid refrigerant dynamic slug.

For further details, please refer to Parallel application guidelines FRCC.PC.008.

When compressors are installed in parallel, in order to limit liquid amount handled per compressor when beginning and ending defrost, it is recommended to avoid running part load (keep all compressors running or keep them stopped when moving 4-way valves).

EXV can also be opened when compressors are stopped and before 4 way valve is moving in order to decrease pressure difference. Opening degree and time have to be set in order to keep a minimum pressure difference for 4 way valve moving. Each application design however should be thoroughly tested to ensure acceptable operating characteristics.

Suction line accumulator

The use of a suction line accumulator is strongly recommended in reversible-cycle applications. This because of the possibility of a substantial quantity of liquid refrigerant remaining in the evaporator, which acts as a condenser during the heating cycle.

Sustained and repeated liquid slugging and flood back can seriously impair the oil's ability to lubricate the compressor bearings. This situation can be observed in wet climates where it is necessary to frequently defrost the outdoor coil in an air source heat pump. In such cases a suction accumulator becomes mandatory.

This liquid refrigerant can then return to the compressor, either flooding the sump with refrigerant or as a dynamic liquid slug when the cycle switches back to a defrost cycle or to normal cooling operations.

Water utilizing systems

Apart from residual moisture in the system after commissioning, water could also enter the refrigeration circuit during operation. Water in the system shall always be avoided. Not only because it can quickly lead to electrical failure, sludge in sump and corrosion but in particular because it can cause serious safety risks.

Common causes for water leaks are corrosion and freezing.

Corrosion: Materials in the system shall be compliant with water and protected against corrosion.

Freezing: When water freezes into ice its volume expands which can damage heat exchanger walls and cause leaks. During off periods water inside heat exchangers could start freezing when ambient temperature is lower than 0°C. During on periods ice banking could occur when the circuit is running continuously at too low load. Both situations should be avoided by connecting a pressure and thermostat switch in the safety line.

Starting sound level

During start-up transients it is natural for the compressor sound level to be slightly higher than during normal running. SH scroll compressors exhibit very little increased start-up transient sound. If a compressor is miswired, the compressor will run in reverse. Reverse

compressor rotation is characterised by an objectionable sound. To correct reverse rotation, disconnect power and switch any two of the three power leads at the unit contactor. Never switch leads at the compressor terminals.

Running sound level

Compressor acoustic hoods have been developed to meet specific extra-low noise requirements.

2 to 4 dBA. Surface sump accessories are available from Danfoss (see section "Accessories").

An additional bottom hood provided in surface sump heater accessories for SH180-240-295-380-485 models provides an additional attenuation of

The acoustic hoods and bottom insulations incorporate sound proofing materials and offer excellent high and low frequency attenuation.

Model	50 Hz		60 Hz		Acoustic hood code number
	Sound power dB(A)	Attenuation dBA ①	Sound power dB(A)	Attenuation dBA ①	
SH090	70	6	72	6	120Z0034
SH105	71.5	6	74	6	120Z0035
SH120	72.5	6	75	6	120Z0035
SH140 *	72.5	6	76	6	120Z0035
SH161 *	73.5	6	77	6	120Z0035
SH184	75	6	78	6	120Z0135
SH180	80	6	85	4	120Z0022
SH240	82	6	86	4	120Z0022
SH295	82	6	86	4	120Z0022
SH380 **	83	6	87	4	120Z0022
SH485	89	4	91	4	120Z0022

Sound power and attenuation are given at ARI conditions, measured in free space
 Data given for motor code 4 compressor, for full data details refer to online datasheet generator: www.danfoss.com/odsg

* For SH140 code 3 and SH161 code 3 use acoustic hood reference 120Z0135

** For SH380 code 3 use acoustic hood reference 120Z0579

① Attenuation given with acoustic hood only

Materials are UL approved and RoHS compliant

Stopping sound level

SH compressors are equipped with a discharge valve which closes at compressor shut down and thus prevents the compressor from running backwards. This reduces the stopping sound to a metallic click caused by the closing valve.

When the pressure difference or gas flow at shut down should be very low, this can delay the discharge valve from closing and lead to a longer noise duration.

Sound generation in a refrigeration or air conditioning system

Typical sound and vibration in refrigeration and air conditioning systems encountered by design and service engineers may be broken down into the following three source categories.

Mechanical vibrations: these generally extend along the parts of the unit and structure.

Gas pulsation: this tends to travel through the cooling medium, i.e. the refrigerant.

Sound radiation: this generally takes an airborne path.

The following sections focus on the causes and methods of mitigation for each of the above sources.

Compressor sound radiation

For sound radiating from the compressor, the emission path is airborne and the sound waves are travelling directly from the machine in all directions.

The Danfoss SH scroll compressor is designed to be quiet and the frequency of the sound generated is pushed into the higher ranges, which not only are easier to reduce but also do not generate the penetrating power of lower-frequency sound.

Use of sound-insulation materials on the inside of unit panels is an effective means of substantially reducing the sound being transmitted to the outside. Ensure that no components capable of transmitting sound/vibration within the unit come into direct contact with any non-insulated parts on the walls of the unit.

Due to the unique Danfoss design of a full-suction gas-cooled motor, compressor body insulation across its entire operating range is possible. Acoustic hoods are available from Danfoss as accessories. They have been developed to meet specific extra low noise requirements. They incorporate sound proofing materials and offer excellent high and low frequency alternative.

These hoods are quick and easy to install and do not increase the overall size of the compressors to a great extent.

Refer to section "Running sound level" for sound attenuation and code numbers.

Mechanical vibrations

Vibration isolation constitutes the primary method for controlling structural vibration. Danfoss SH scroll compressors are designed to produce minimal vibration during operations. The use of rubber isolators on the compressor base plate or on the frame of a manifolded unit is very effective in reducing vibration being transmitted from the compressor(s) to the unit. Once the supplied rubber grommets have been properly mounted, vibrations transmitted from the compressor base plate to the unit are held to a strict minimum. In addition, it is extremely important that the frame supporting the mounted compressor be of sufficient mass and stiffness to help dampen any residual vibration potentially transmitted to the frame. For further

information on mounting requirements, please refer to the section on mounting assembly.

Note: for parallel assemblies see specific recommendations in Danfoss SH parallel application guidelines FRCC.PC.008 (rigid mounting).

The tubing should be designed so as to both reduce the transmission of vibrations to other structures and withstand vibration without incurring any damage. Tubing should also be designed for three-dimensional flexibility. For more information on piping design, please see the section entitled "Essential piping design recommendations".

Gas pulsation

The Danfoss SH scroll compressor has been designed and tested to ensure that gas pulsation has been optimised for the most commonly encountered air conditioning pressure ratio. On heat pump installations and other installations where the pressure ratio lies beyond the typical range, testing should be conducted

under all expected conditions and operating configurations to ensure that minimum gas pulsation is present. If an unacceptable level is identified, a discharge muffler with the appropriate resonant volume and mass should be installed. This information can be obtained from the component manufacturer.

Each SH compressor is shipped with printed Instructions for installation. These instructions can also be downloaded from our website:

www.danfoss.com or directly from:
<http://instructions.cc.danfoss.com>

Compressor handling and storage

Each Danfoss SH scroll compressor is equipped with two lift rings on the top shell. Always use both these rings when lifting the compressor. Use lifting equipment rated and certified for the weight of the compressor. A spreader bar rated for the weight of the compressor is highly recommended to ensure a better load distribution. The use of lifting hooks closed with a clasp and certified to lift the weight of the compressor is also highly recommended. Always respect the appropriate rules concerning lifting objects of the type and weight of these compressors. Maintain the compressor in an upright position during all handling manoeuvres (maximum of 15° from vertical).

⚠ When the compressor is mounted as part of an installation, never use the lift rings on the compressor to lift the installation. The risk is run that the lugs could separate from the compressor or that the compressor could separate from the base frame with extensive damage and possible personal injury as a result.

Never apply force to the terminal box with the intention of moving the compressor, as the force placed upon the terminal box can cause extensive damage to both the box and the components contained inside.

⚠ Never use only one lifting lug to lift the compressor. The compressor is too heavy for the single lug to handle, and the risk is run that the lug could separate from the compressor with extensive damage and possible personal injury as a result.

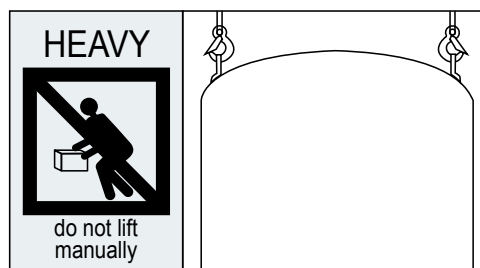

Store the compressor not exposed to rain, corrosive or flammable atmosphere and between -35°C and 51°C when charged with R410A refrigerant and between -35°C and 70°C when charged with nitrogen.

Compressor mounting

Maximum inclination from the vertical plane while operating must not exceed three degrees.

Mounting of SH090-105-120-140-161-184

Compressors SH090-105-120-140-161-184 come delivered with four rubber mounting grommets and metal sleeve liners that serve to isolate the compressor from the base frame. These grommets must always be used to mount the compressor in a single application. The grommets must be compressed until contact between the flat washer and the steel mounting sleeve is established. The grommets attenuate to a great extent the transmission of compressor vibrations to the base frame.

The required bolt size for the SH 090 -105-120-140-161-184 compressors is HM8-40. This bolt must be tightened to a torque of 15 Nm.

For parallel assemblies see specific recommendations in Danfoss SH parallel application guidelines (rigid mounting).

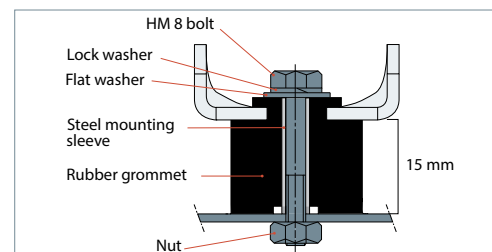

When a surface sump heater is used, it must be applied after the grommets are mounted on

compressor feet, in order to avoid surface sump heater damage.

Mounting of SH180-240-295-380-485

Compressors SH180-240-295-380-485 come delivered with rigid mounting spacers for parallel mounting.

If used in single applications, the compressor must be mounted with the flexible grommets as available in accessory conversion kit 8156138. The grommets must be compressed until contact

between the flat washer and the steel mounting sleeve is established. The grommets attenuate to a great extent the transmission of compressor vibrations to the base frame.

The required bolt size for the SH180-240-295-380-485 compressors is HM8-55. This bolt must be tightened to a torque of 21 Nm.

1 manifoldable compressor with rigid spacers

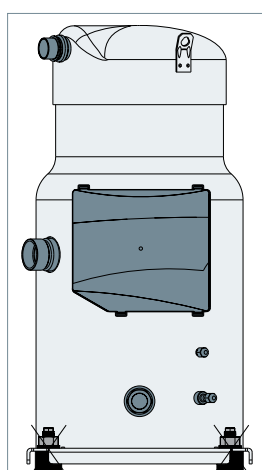

Rigid spacers to remove

1 single compressor with rubber grommets

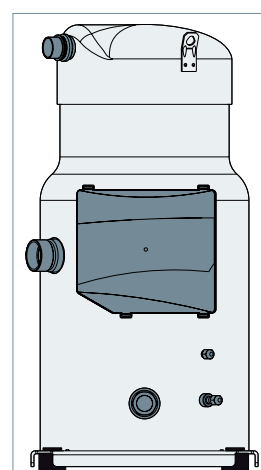

Rubber grommets from kit 8156138

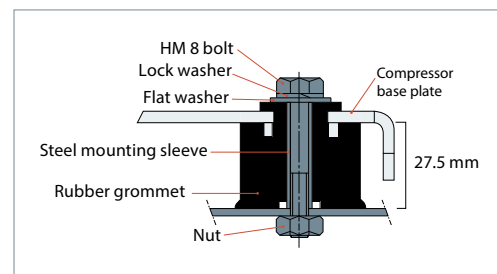
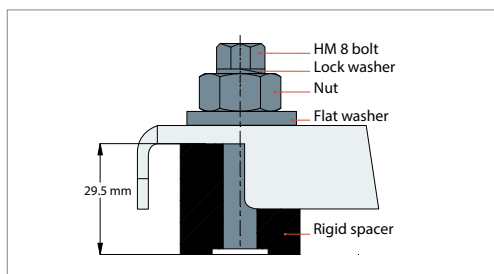

Compressor holding charge

Each compressor is shipped with a nominal dry nitrogen holding charge between 0.3 and 0.7 bar and is sealed with elastomer plugs.

Before the suction and discharge plugs are removed, the nitrogen holding charge must be released via the suction schrader valve to avoid an oil mist blowout. Remove the suction plug

first and the discharge plug afterwards. The plugs shall be removed only just before connecting the compressor to the installation in order to avoid moisture from entering the compressor. When the plugs are removed, it is essential to keep the compressor in an upright position so as to avoid oil spillage.

System cleanliness

The refrigerant compression system, regardless of the type of compressor used, will only provide high efficiency and good reliability, along with a long operating life, if the system contains solely the refrigerant and oil it was designed for. Any other substances within the system will not improve performance and, in most cases, will be highly detrimental to system operations.

The presence of non-condensable substances and system contaminants such as metal shavings, solder and flux, have a negative impact on compressor service life. Many of these contaminants are small enough to pass through a mesh screen and can cause considerable damage within a bearing assembly.

The use of highly hygroscopic polyolester oil in R410A compressors requires that the oil be exposed to the atmosphere as little as possible.

System contamination is one of main factors affecting equipment reliability and compressor service life. It is important therefore to take system cleanliness into account when assembling a refrigeration system.

During the manufacturing process, circuit contamination may be caused by:

- Brazing and welding oxides
- Filings and particles from the removal of burrs in pipe-work
- Brazing flux
- Moisture and air.

Consequently, when building equipment and assemblies, the precautions listed in the following paragraphs must be taken.

Tubing

Only use clean and dehydrated refrigeration-grade copper tubing. Tube-cutting must be carried out so as not to deform the tubing roundness and to ensure that no foreign debris remains within the tubing. Only refrigerant grade fittings should be used and these must be of

both a design and size to allow for a minimum pressure drop through the completed assembly. Follow the brazing instructions on next pages. Never drill holes into parts of the pipe-work where filings and particles can not be removed.

Brazing and soldering

Do not bend the compressor discharge or suction lines or force system piping into the compressor connections, because this will increase stresses that are a potential cause of failure. Recommended brazing procedures and material, are described section "Compressor connection".

These operations must be performed by a qualified personnel in compliance with all pertinent practices and safety procedures.

Copper to copper connections

When brazing copper-to-copper connections, the use of copper/phosphorus brazing alloy containing 5% silver or more with a melting

temperature of below 800°C is recommended. No flux is required during brazing.

Dissimilar metals connection

When manipulating dissimilar metals such as copper and brass or steel, the use of silver solder (5% or more) and anti-oxidant flux is necessary.

Please contact Danfoss Technical support for any deviation from this guidelines.

Compressor connection

When brazing the compressor fittings, do not overheat the compressor shell, which could severely damage certain internal components due to excessive heating. Use of a heat shield and/or a heat-absorbent compound is highly recommended. Due to the relatively sizable tubing and fitting diameters a double-tipped torch using acetylene is recommended for brazing operation on Danfoss SH scroll compressors.

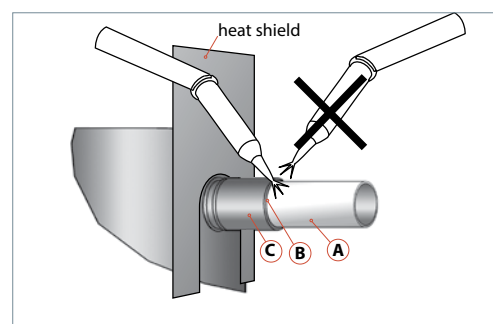

For brazing the suction and discharge connections, the following procedure is advised:

- Make sure that no electrical wiring is connected to the compressor.
- Protect the terminal box and compressor painted surfaces from torch heat damage (see diagram).
- Remove the Teflon gaskets when brazing rotolock connectors with solder sleeves.
- Use only clean refrigeration-grade copper tubing and clean all connections.
- Use brazing material with a minimum of 5% silver content.
- Purge nitrogen or CO₂ through the compressor in order to prevent against oxidation and flammable conditions. The compressor should not be exposed to the open air for extended periods.
- Use of a double-tipped torch is recommended.
- Apply heat evenly to area A until the brazing temperature is reached. Move the torch to area B and apply heat evenly until the brazing temperature has been reached there as well, and then begin adding the brazing material. Move the torch evenly around the joint, in applying only enough brazing material to flow the full circumference of the joint.
- Move the torch to area C only long enough to draw the brazing material into the joint, but not into the compressor.

- Remove all remaining flux once the joint has been soldered with a wire brush or a wet cloth. Remaining flux would cause corrosion of the tubing.

In addition, for discharge connections equipped with a non return valve integrated in discharge fitting (SH180 to SH485) the direction of the torch has to be as described on the picture, and maximum brazing time should be less than 2 minutes to avoid NRVI damages.

Ensure that no flux is allowed to enter into the tubing or compressor. Flux is acidic and can cause substantial damage to the internal parts of the system and compressor.

The polyolester oil used in SH compressors is highly hygroscopic and will rapidly absorb moisture from the air. The compressor must therefore not be left open to the atmosphere for a long period of time. The compressor fitting plugs shall be removed just before brazing the compressor. The compressor should always be the last component brazed into the system

⚠ Before eventual unbrazing the compressor or any system component, the refrigerant charge must be removed from both the high- and low-pressure sides. Failure to do so may result in serious personal injury. Pressure gauges must be used to ensure all pressures are at atmospheric level.

For more detailed information on the appropriate materials required for brazing or soldering, please contact the product manufacturer or distributor. For specific applications not covered herein, please contact Danfoss for further information.

System pressure test

Always use an inert gas such as nitrogen for pressure testing. Never use other gasses such as oxygen, dry air or acetylene as these may form

an inflammable mixture. Do not exceed the following pressures:

Maximum compressor test pressure (low side)	30.2 bar (g) for SH180 to 485 33.3 bar(g) for SH090 to 184
Maximum compressor test pressure (high side)	45 bar (g)
Maximum pressure difference between high and low side of the compressor	37 bar

Application Guidelines

Installation

Pressurize the system on HP side first then LP side to prevent rotation of the scroll. Never let the pressure on LP side exceed the pressure on HP side with more than 5 bar.

if an external non return valve is present on the discharge line, we advise to pressurize the system not quicker than 4.8 bar/s to allow pressure equalization between LP and HP side over scroll elements.

On SH180-240-295-380-485 models which have an internal non return valve in discharge fitting or

Leak detection

Leak detection must be carried out using a mixture of nitrogen and refrigerant or nitrogen and helium, as indicated in the table below. Never use other gasses such as oxygen, dry air

or acetylene as these may form an inflammable mixture.

Pressurize the system on HP side first then LP side.

Leak detection with refrigerant	Leak detection with a mass spectrometer
Nitrogen and R410A	Nitrogen and Helium

Note 1: Leak detection with refrigerant may be forbidden in some countries. Check local regulations.

Note 2: The use of leak detecting additives is not recommended as they may affect the lubricant properties.

Vacuum evacuation and moisture removal

Moisture obstructs the proper functioning of the compressor and the refrigeration system.

SH compressors are delivered with < 100 ppm moisture level. The required moisture level in the circuit after vacuum dehydration must be < 100 ppm for systems with an SH.

Air and moisture reduce service life and increase condensing pressure, and cause excessively high discharge temperatures, which can destroy the lubricating properties of the oil. Air and moisture also increase the risk of acid formation, giving rise to copper plating. All these phenomena can cause mechanical and electrical compressor failure.

- Never use the compressor to evacuate the system.
- Connect a vacuum pump to both the LP and HP sides.
- Evacuate the system to a pressure of 500 µm Hg (0.67 mbar) absolute.

For these reasons it is important to perform a vacuum dehydration on the system to remove all residual moisture from the pipe-work after assembly;

Do not use a megohm meter nor apply power to the compressor while it is under vacuum as this may cause internal damage.

Filter driers

A properly sized and type of drier is required. Important selection criteria include the driers water content capacity, the system refrigeration capacity and the system refrigerant charge. The drier must be able to reach and maintain a moisture level of 50 ppm end point dryness (EPD).

The drier is to be oversized rather than under sized. When selecting a drier, always take into account its capacity (water content capacity), the system refrigeration capacity and the system refrigerant charge.

For new installations with SH compressors with polyolester oil, Danfoss recommends using the Danfoss DML (100% molecular sieve) solid core filter drier. Molecular sieve filter driers with loose beads from third party suppliers shall be avoided. For servicing of existing installations where acid formation is present the Danfoss DCL (solid core) filter driers containing activated alumina are recommended.

After burn out, remove and replace the liquid line filter drier and install a Danfoss type DAS burn-out drier of the appropriate capacity. Refer to the DAS drier instructions and technical information for correct use of the burnout drier on the liquid line.

Refrigerant charging

For the initial charge the compressor must not run and eventual service valves must be closed. Charge refrigerant as close as possible to the nominal system charge before starting the compressor. This initial charging operation must be done in liquid phase. The best location is on the liquid line between the condenser outlet and the filter drier. Then during commissioning, when needed, a complement of charge can be done in liquid phase: slowly throttling liquid in on the low pressure side as far away as possible from the compressor suction connection while compressor is running. The refrigerant charge quantity must be suitable for both summer and winter operations.

Vacuum or charge from one side can seal the scrolls and result in a non-starting compressor. When servicing, always ensure that LP/HP pressures are balanced before starting the compressor.

Be sure to follow all government regulations regarding refrigerant reclamation and storage.

For more detailed information see "Recommended refrigerant system charging practice" news bulletin FRCC.EN.050.

Insulation resistance and dielectric strength

Insulation resistance must be higher than 1 megohm when measured with a 500 volt direct current megohm tester.

values to ground and higher leakage current readings. Such readings do not indicate a faulty compressor.

Each compressor motor is tested at the factory with a high potential voltage (hi-pot) that exceeds the UL requirement both in potential and in duration. Leakage current is less than 5 mA.

In testing insulation resistance, Danfoss recommends that the system be first operated briefly to distribute refrigerant throughout the system. Following this brief operation, retest the compressor for insulation resistance or current leakage.

SH scroll compressors are configured with the pump assembly at the top of the shell, and the motor below. As a result, the motor can be partially immersed in refrigerant and oil. The presence of refrigerant around the motor windings will result in lower resistance

Never reset a breaker or replace a fuse without first checking for a ground fault (a short circuit to ground). Be alert for sounds of arcing inside the compressor.

Commissioning

The system must be monitored after initial start-up for a minimum of 60 minutes to ensure proper operating characteristics such as:

- Proper metering device operation and desired superheat readings
- Suction and discharge pressure are within acceptable levels
- Correct oil level in compressor sump indicating proper oil return

- Low foaming in sight glass and compressor sump temperature 10K above saturation temperature to show that there is no refrigerant migration taking place
- Acceptable cycling rate of compressors, including duration of run times
- Current draw of individual compressors within acceptable values (max operating current)
- No abnormal vibrations and noise.

Oil level checking and top-up

In installations with good oil return and line runs up to 20 m, no additional oil is required. If installation lines exceed 20 m, additional oil may be needed. 1 or 2% of the total system refrigerant charge (in weight) can be used to roughly define the required oil top-up quantity but in any case the oil charge has to be adjusted based on the oil level in the compressor sight glass.

When the compressor is running under stabilised conditions the oil level must be visible in the sight glass.

The presence of foam filling in the sight glass indicates large concentration of refrigerant in the oil and / or presence of liquid returning to the compressor.

The oil level can also be checked a few minutes after the compressor stops.

When the compressor is off, the level in the sight glass can be influenced by the presence of refrigerant in the oil.

Always use original Danfoss POE oil 160SZ from new cans.

Top-up the oil while the compressor is idle. Use the schrader connector or any other accessible connector on the compressor suction line and a suitable pump. See News bulletin "Lubricants filling in instructions for Danfoss Commercial Compressors".

Packaging
Single pack

Compressor models	Length (mm)	Width (mm)	Height (mm)	Gross weight (kg)
SH090	565	470	718	69
SH105	565	470	718	76
SH120	565	470	718	76
SH140	565	470	718	79
SH161	565	470	718	81
SH184	565	470	718	84
SH180	760	600	900	122
SH240	760	600	900	122
SH295	760	600	900	125
SH380	760	600	900	172
SH485	760	600	900	189

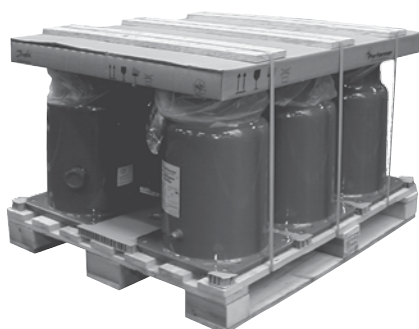
Industrial pack

Compressor models	Nbr*	Length (mm)	Width (mm)	Height (mm)	Gross weight (kg)	Static stacking pallets
SH090	8	1150	950	680	494	2
SH105	8	1150	950	750	544	2
SH120	8	1150	950	750	544	2
SH140	8	1150	950	750	566	2
SH161	8	1150	950	750	582	2
SH184	8	1150	950	750	606	2
SH180	6	1150	965	768	685	2
SH240	6	1150	965	768	683	2
SH295	6	1150	965	768	702	2
SH380	4	1150	965	800	671	2
SH485	4	1150	965	800	737	2

* nbr: number of compressors per pack

Ordering information

Danfoss SH scroll compressors can be ordered in either industrial packs or in single packs. Please use the code numbers from below tables for ordering.

Compressors SH180 to 485 with rigid mounting spacers are dedicated for parallel mounting. For use in single applications the rigid spacers must be replaced by flexible grommets which are available as accessory kit 8156138, see section "Accessories".

Single pack

Compressor model	Connections	Mounting feet	Motor protection	Code no.				
				3	4	6	7	9
				200-230/3/60	460/3/60 380-400/3/50	230/3/50	575/3/60 500/3/50	380/3/60
SH090	Brazed	Flexible	Internal	120H0001	120H0003	120H0005	120H0007	120H0009
SH105	Brazed	Flexible	Internal	120H0209	120H0211	120H0213	120H0215	120H0217
SH120	Brazed	Flexible	Internal	120H0011	120H0013	120H0015	120H0017	120H0019
SH140	Brazed	Flexible	Internal	120H0199	120H0201	120H0203	120H0205	120H0207
SH161	Brazed	Flexible	Internal	120H0021	120H0023	120H0025	120H0027	120H0029
SH184	Brazed	Flexible	Internal	120H0359	120H0361	120H0363	120H0365	120H0367
SH180	Brazed	Rigid	Module 24V AC *	120H0265	120H0267	-	120H0269	120H0271
	Brazed	Rigid	Module 110-240V *	120H0273	120H0275	-	120H0277	120H0279
SH240	Brazed	Rigid	Module 24V AC *	120H0289	120H0291	-	120H0293	120H0295
	Brazed	Rigid	Module 110-240V *	120H0297	120H0299	-	120H0301	120H0303
SH295	Brazed	Rigid	Module 24V AC*	120H0851	120H0825	-	120H0833	120H0841
	Brazed	Rigid	Module 110-240V*	120H0853	120H0827	-	120H0835	120H0843
SH380	Brazed	Rigid	Module 24V AC *	120H0151	120H0253	-	120H0257	120H0261
	Brazed	Rigid	Module 110-240V *	120H0152	120H0255	-	120H0259	120H0263
SH485	Brazed	Rigid	Module 24V AC *	-	120H1062	-	120H1099	120H1072
	Brazed	Rigid	Module 110-240V *	-	120H1064	-	120H1098	120H1074

* Electronic motor protection, module located in terminal box

Industrial pack



Compressor model	Connections	Mounting feet	Motor protection	Code no.		
				3	4	9
				200-230/3/60	400/3/50 460/3/60	380/3/60
SH090	Brazed	Flexible	Internal	120H0002	120H0004	120H0010
SH105	Brazed	Flexible	Internal	120H0210	120H0212	120H0218
SH120	Brazed	Flexible	Internal	120H0012	120H0014	120H0020
SH140	Brazed	Flexible	Internal	120H0200	120H0202	120H0208
SH161	Brazed	Flexible	Internal	120H0022	120H0024	120H0030
SH184	Brazed	Flexible	Internal	120H0360	120H0362	120H0368
SH180	Brazed	Rigid	Module 24V AC *	120H0266	120H0268	120H0272
	Brazed	Rigid	Module 110-240V *	120H0274	120H0276	120H0280
SH240	Brazed	Rigid	Module 24V AC *	120H0290	120H0292	120H0296
	Brazed	Rigid	Module 110-240V *	120H0298	120H0300	120H0304
SH295	Brazed	Rigid	Module 24V AC*	120H0852	120H0826	120H0842
	Brazed	Rigid	Module 110-240V*	120H0854	120H0828	120H0844
SH380	Brazed	Rigid	Module 24V AC *	120H0250	120H0254	120H0262
	Brazed	Rigid	Module 110-240V *	120H0252	120H0256	120H0264
SH485	Brazed	Rigid	Module 24V AC *	-	120H1063	120H1073
	Brazed	Rigid	Module 110-240V *	-	120H1065	120H1075

* Electronic motor protection, module located in terminal box

Solder sleeve adapter set

Type	Code n°	Description	Application	Packaging	Pack size
	120Z0125	Rotolock adaptor set (1"3/4 ~ 1"1/8) , (1"1/4 ~ 7/8")	SH090	Multipack	8
	120Z0405	Rotolock adaptor set (1"3/4 ~ 1"3/8) , (1"1/4 ~ 7/8")	SH105 to 184	Multipack	8
	7765006 *	Rotolock adaptor set (1"3/4 ~ 1"3/8) , (1"1/4 ~ 7/8")	SH105 to 184	Multipack	6
	7765028	Rotolock adaptor set (2"1/4 ~ 1"5/8) , (1"3/4 ~ 1"1/8)	SH180-240-295-380	Multipack	6
	120Z0504	Rotolock adaptor set (2"1/4 ~ 1"5/8), (1"3/4 ~ 1"3/8)	SH485	Multipack	6

* diameter restriction

Rotolock adapter

Type	Code n°	Description	Application	Packaging	Pack size
	120Z0367	Adaptor (1"1/4 Rotolock - 7/8" ODS)	Models with 7/8" ODF	Multipack	10
	120Z0364	Adaptor (1"3/4 Rotolock - 1"1/8 ODS)	Models with 1"1/8 ODF	Multipack	10
	120Z0431	Adaptor (1"3/4 Rotolock - 1"3/8 ODS)	Models with 1"3/8 ODF	Multipack	10
	120Z0432	Adaptor (2"1/4 Rotolock - 1"5/8 ODS)	Models with 1"5/8 ODF	Multipack	10

Gaskets

Type	Code n°	Description	Application	Packaging	Pack size
G09	8156131	Gasket, 1"1/4	Models with 1"1/4 rotolock connection	Multipack	10
G09	7956002	Gasket, 1"1/4	Models with 1"1/4 rotolock connection	Industry pack	50
G07	8156132	Gasket, 1"3/4	Models with 1"3/4 rotolock connection	Multipack	10
G07	7956003	Gasket, 1"3/4	Models with 1"3/4 rotolock connection	Industry pack	50
G08	8156133	Gasket, 2"1/4	Models with 2"1/4 rotolock connection	Multipack	10
G08	7956004	Gasket, 2"1/4	Models with 2"1/4 rotolock connection	Industry pack	50
	8156013	Gasket set 1"1/4 - 1"3/4 - 2"1/4, OSG gaskets black and white	All Rotolock models	Multipack	10

Solder sleeve

Type	Code n°	Description	Application	Packaging	Pack size
P02	8153004	Solder sleeve P02 (1"3/4 Rotolock - 1"1/8 ODF)	Models with 1"3/4 rotolock connection	Multipack	10
P02	7953005	Solder sleeve P02 (1"3/4 Rotolock - 1"1/8 ODF)	Models with 1"3/4 rotolock connection	Industry pack	50
P03	8153006	Solder sleeve P03 (2"1/4 Rotolock - 1"5/8 ODF)	Models with 2"1/4 rotolock connection	Multipack	10
P03	7953006	Solder sleeve P03 (2"1/4 Rotolock - 1"5/8 ODF)	Models with 2"1/4 rotolock connection	Industry pack	50
P04	8153008	Solder sleeve P04 (1"1/4 Rotolock - 3/4" ODF)	Models with 1"1/4 rotolock connection	Multipack	10
P04	7953007	Solder sleeve P04 (1"1/4 Rotolock - 3/4" ODF)	Models with 1"1/4 rotolock connection	Industry pack	50
P05	8153012	Rotolock connector P05 (1"1/4 Rotolock - 7/8" ODF)	Models with 1"1/4 rotolock connection	Multipack	10
P05	7953008	Rotolock connector P05 (1"1/4 Rotolock - 7/8" ODF)	Models with 1"1/4 rotolock connection	Industry pack	50
P07	8153013	Solder sleeve P07 (1"3/4 Rotolock - 7/8" ODF)	Models with 1"3/4 rotolock connection	Multipack	10
P07	7953010	Solder sleeve P07 (1"3/4 Rotolock - 7/8" ODF)	Models with 1"3/4 rotolock connection	Industry pack	50
P08	8153005	Solder sleeve P08 (2"1/4 Rotolock - 1"3/8 ODF)	Models with 2"1/4 rotolock connection	Multipack	10
P10	8153003	Solder sleeve P10 (1"3/4 Rotolock - 1"3/8 ODF)	Models with 1"3/4 rotolock connection	Multipack	10

Rotolock nut

Type	Code n°	Description	Application	Packaging	Pack size
	8153123	Rotolock nut,1"1/4	Models with 1-1/4" rotolock connection	Multipack	10
	7953002	Rotolock nut,1"1/4	Models with 1-1/4" rotolock connection	Industry pack	50
	8153124	Rotolock nut,1"3/4	Models with 1-3/4" rotolock connection	Multipack	10
	7953003	Rotolock nut,1"3/4	Models with 1-3/4" rotolock connection	Industry pack	50
	8153126	Rotolock nut,2"1/4	Models with 2-1/4" rotolock connection	Multipack	10
	120Z0047	Rotolock nut,2"1/4	Models with 2-1/4" rotolock connection	Industry pack	50

Rotolock service valve set

Type	Code n°	Description	Application	Packaging	Pack size
	7703008	Valve set, V02 (1"3/4 ~ 1"1/8), V05 (1"1/4 ~ 7/8")	SH090	Multipack	6
	120Z0403	Valve set, V02 (1"3/4 ~ 1"1/8), V05 (1"1/4 ~ 7/8")	SH090	Multipack	8
	7703392	Valve set, V10 (1"3/4 ~ 1"3/8), V05 (1"1/4 ~ 7/8")	SH105 to 184	Multipack	6
	7703383	Valve set, V03 (2"1/4 ~ 1"5/8), V02 (1"3/4 ~ 1"1/8)	SH180 to 380	Multipack	4
	120Z0547	Valve set, V03 (2"1/4 ~ 1"5/8), V10 (1"3/4 ~ 1"3/8)	SH485	Multipack	4

* diameter restriction

3-phase soft start equipment

Type	Code n°	Description	Application	Packaging	Pack size
MCI 15 C	7705006	Electronic soft start kit, MCI 15 C	SH090	Single pack	1
MCI 25 C	7705007	Electronic soft start kit, MCI 25 C	SH105-120-140-161-184	Single pack	1
MCI 50 CM	037N0401	Electronic soft start kit, MCI 50 C	SH 180-240-295-380	Single pack	1
MCD201-055	175G5205	Electronic soft starter MCD201-055-T6-CV1	SH485	Single pack	1

Motor protection modules

Type	Code n°	Description	Application	Packaging	Pack size
	120Z0584	Electronic motor protection module, 24 V AC	SH180-240-295-380-485	Single pack	1
	120Z0585	Electronic motor protection module, 110-240 V		Single pack	1

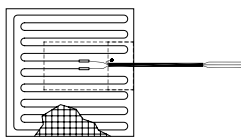
Surface sump heaters

	Code no.	Accessory description	Application	Packaging	Pack size
	120Z0388	80W 24V surface sump heater CE and UL	SH090-105-120-140-161-184	Multipack	8
	120Z0389	80W 230V surface sump heater CE and UL		Multipack	8
	120Z0390	80W 400V surface sump heater CE and UL		Multipack	8
	120Z0391	80W 460V surface sump heater CE and UL		Multipack	8
	120Z0402	80W 575V surface sump heater CE and UL		Multipack	8
	120Z0360	56W 24V surface sump heater + bottom insulation, CE and UL	SH180-240-295-380-485	Multipack	6
	120Z0376	56W 230V surface sump heater + bottom insulation, CE and UL		Multipack	6
	120Z0377	56W 400V surface sump heater + bottom insulation, CE and UL		Multipack	6
	120Z0378	56W 460V surface sump heater + bottom insulation, CE and UL		Multipack	6
	120Z0379	56W 575V surface sump heater + bottom insulation, CE and UL		Multipack	6

Discharge temperature protection

Type	Code No	Description	Application	Packaging	Pack Size
	7750009	Discharge thermostat kit	SH090 to SH380	Multipack	10
	7973008	Discharge thermostat kit	SH090 to SH380	Industry pack	50

Mounting hardware

Type	Code No	Description	Application	Packaging	Pack Size
	120Z0066	Mounting kit for scroll compressors. Grommets, sleeves, bolts, washers	SH090-184	Single pack	1
	8156138	Mounting kit for scroll compressors. Grommets, sleeves, bolts, washers	SH180-485	Single pack	1
	7777045	Mounting kit for 1 scroll compressors including 4 hexagon rigid spacer, 4 sleeves, 4 bolts, 4 washers	SH180-485 in parallel installation	Single pack	1
	120Z0495	Mounting kit for 1 scroll compressor including 4 triangle rigid spacer, 4 sleeves, 4 bolts, 4 washers	SH180-485 in parallel installation	Single pack	1

Acoustic hoods

Type	Code No	Description	Application	Packaging	Pack Size
	120Z0034	Acoustic hood for scroll compressor	SH090	Single pack	1
	120Z0035	Acoustic hood for scroll compressor	SH105-120-140-161 (except SH161 - 140 code 3)	Single pack	1
	120Z0135	Acoustic hood for scroll compressor	SH184-SH161 code 3 -SH140 code 3	Single pack	1
	120Z0022	Acoustic hood for scroll compressor	SH 180-240-295-380*-485	Single pack	1
	120Z0579	Acoustic hood for scroll compressor	SH 380 code 3	Single pack	1
	120Z0353	Bottom insulation for scroll compressor	SH180-240-295-380-485	Single pack	1

* except code 3

Terminal boxes, covers and T-block connectors

Type	Code No	Description	Application	Packaging	Pack Size
	120Z0413	Terminal box cover	SH184-140 and 161 code 3	Single pack	1
	8156135	Service kit for terminal box 96 x 115 mm, including 1 cover, 1 clamp	SH090-105-120-140-161 (except SH140-3 and SH161-3)	Multipack	10
	8173230	T block connector 52 x 57 mm	SH090-105-120-140-161 (except 140-3 and 161-3)	Multipack	10
	8173021	T block connector 60 x 75 mm	SH140-3,161-3,184-180-240-295-380 (except 240-3, 295-3)	Multipack	10
	8173331	T block connector 80 x 80 mm	SH240-295-380 code 3-485	Multipack	10
	120Z0458	Terminal box 210 x 190 mm, incl. cover	SH180-240-295-380-485	Single pack	1
	120Z0462	Terminal box 210 x 190, incl. cover and module wiring for 258 x 208 and 186 x 198 terminal box replacement	SH180-240-295-380*-485	Single pack	1
	120Z0150	Terminal box cover	SH380 code 3	Single pack	1

* except code 3

Lubricant

Type	Code No	Description	Application	Packaging	Pack Size
160SZ	7754023	POE lubricant, 1 litre can	All models	Multipack	12
160SZ	120Z0571	POE lubricant, 2.5 litre can	All models	Multipack	4

Miscellaneous

Type	Code No	Description	Application	Packaging	Pack Size
	8156019	Sight glass with gaskets (black and white)	All models	Multipack	4
	8156129	Gasket for oil sight glass, 1"1/8 (white teflon)	All models	Multipack	10
	7956005	Gasket for oil sight glass, 1"1/8 (white teflon)	All models	Multipack	50
	8154001	Danfoss Commercial Compressors blue spray paint	All models	Single pack	1

Previous Version

- Page 6: Nomenclature
- Page 14: Motor voltage
- Page 15: SH240-295-380-485
- Page 19: Compressor model SH240-295-380
- Page 20: PTC overheat & Delay timer active
- Page 21: In case of phase reverse error & In case of phase loss error
- Page 26: R410A pressure settings
- Page 44: Packaging (single pack)

- Page 48: Motor protection modules

Current Version

- Page 6: Updated Motor protection in nomenclature.
- Page 14: Updated code4 for voltage range 50 Hz in motor voltage.
- Page 15: Added SH180 with SH240-295-380-485 & updated SH380 code3.
- Page 19: Added SH180 with compressor model SH240-295-380.
- Page 20: Updated drawings for PTC overheat & Delay timer active.
- Page 21: Updated drawings for In case of phase reverse error & In case of phase loss error.
- Page 26: Updated R410A pressure settings. 2.3 bar(g) is replaced by 1.7 bar(g).
- Page 44: Updated length dimensions in packaging (single pack).
- Replaced "230 V" by "110-240 V"
- Replaced "115-230 V" by "110-240 V"
- Page 48: Updated Motor protection modules in accessories.

Danfoss Commercial Compressors

is a worldwide manufacturer of compressors and condensing units for refrigeration and HVAC applications. With a wide range of high quality and innovative products we help your company to find the best possible energy efficient solution that respects the environment and reduces total life cycle costs.

We have 40 years of experience within the development of hermetic compressors which has brought us amongst the global leaders in our business, and positioned us as distinct variable speed technology specialists. Today we operate from engineering and manufacturing facilities spanning across three continents.

 <p>Danfoss Scrolls</p>	 <p>Danfoss Inverter Scrolls</p>	 <p>Danfoss Turbocor Compressors</p>
 <p>Secop Compressors for Danfoss</p>	 <p>Danfoss Maneurop Reciprocating Compressors</p>	 <p>Danfoss Optyma Condensing Units</p>

Our products can be found in a variety of applications such as rooftops, chillers, residential air conditioners, heatpumps, coldrooms, supermarkets, milk tank cooling and industrial cooling processes.

<http://cc.danfoss.com>

Danfoss Commercial Compressors, BP 331, 01603 Trévoux Cedex, France | +334 74 00 28 29



Danfoss can accept no responsibility for possible errors in catalogues, brochures and other printed material. Danfoss reserves the right to alter its products without notice. This also applies to products already on order provided that such alterations can be made without subsequential changes being necessary in specifications already agreed. All trademarks in this material are property of the respective companies. Danfoss and the Danfoss logotype are trademarks of Danfoss A/S. All rights reserved.