

Copeland Scroll™ Compressor ZBKQ for Refrigeration Applications



Product Catalogue

COPELAND™

EMERSON™

Table of contents

Features and benefits	03
Nomenclature	05
Bill of material	05
Operating envelopes	06
Product line-up	08
Performance data	09
Technical data	46
Dimensional drawings	49
Electrical wiring diagram	64
Quick application guide	66
Available models list	76
Contact list	80



Emerson is the world’s leading compressor manufacturer and is committed to maximizing system efficiency and protecting the environment. We offer a wide range of solutions for commercial refrigeration applications. The Copeland Scroll™ ZB Compressor is widely recognized in the refrigeration market for its reliability and low running cost in high and medium temperature applications. The newly released ZB large refrigeration scroll compressor expands the current ZB product line to 30 HP and is optimized for medium temperature applications for best-in-class seasonal energy efficiency. ZB refrigeration scrolls offer customers an excellent solution to replacing traditional semi-hermetic compressors and lead the transition to scroll technology.

Features and benefits

Robust and reliable

Copeland Scroll compressors have 70% fewer moving parts than reciprocating compressors and feature a scroll Compliance mechanism which makes them particularly robust and reliable under severe conditions including liquid slugging.

Dual compliance

Compliance means sealing between the orbiting and fixed scroll involutes. Dual compliance means the sealing is on both the axial and radial directions. This prevents refrigerant leak back across successive scroll pressure pockets. Compliance design also allows the scroll involutes to separate in both the radial and axial directions. This allows debris or liquid refrigerant to pass through the scroll involutes without damaging the compressor. Benefits of Dual Compliance are:

- Increased efficiency
- Better liquid handling capability
- Better handling of debris

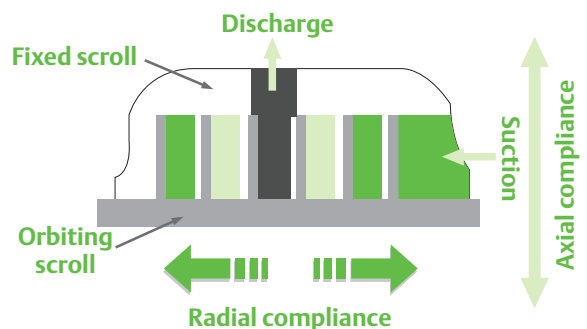

Scroll wear in

The scroll involutes of Copeland scroll compressor wear in, rather than wear out. So unlike in other compressor technologies among similar categories, there is no constant degradation of performance with time due to wear out.

Lower sound, vibration and pulsation

The compression process in a scroll set is symmetrical and continuous. This inherently reduces the sound, vibration and pulsation. This eliminates the need for use of vibration absorbers and suction or discharge mufflers in most of the applications. In further, ZB scroll compressors are engineered to produce smooth sound spectrum which improves the quality of sound.

Unloaded start

The scroll sets separate at the instant of compressor shutdown. This allows the scroll set internal pressures to equalize on compressor stops. In addition to this, the scroll sets are not engaged at the instant of starting. Scroll sets engage only after few milliseconds of startup. This allows easier startup of ZB scroll compressors. Due to this design feature, typically a start assist kit is not required even on single phase compressors.

DU bearings

A space age bearing material comprising of porous bronze with PTFE-lead overlay. These bearings are used in ZB scroll compressors in the scroll drive and main bearings. DU bearings work with exceptionally low friction between the load bearing surfaces. In addition, DU bearings can operate safely for a short time with loss of lubrication. This situations could happen on compressor applications due to oil pump out during a flooded start or heavy oil dilution after a defrost cycle.

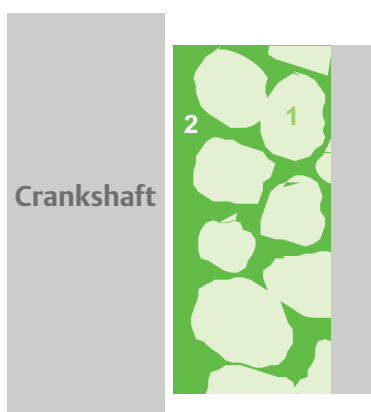

Compactness

Copeland Scroll have the advantage of light weight and compactness with small footprint, making them ideal for the usage in condensing units, compact refrigeration systems or special process units. Weight and dimensions for refrigeration equipment is reduced accordingly.

High efficiency all year round

Copeland ZB Scroll is designed for medium-high temperature refrigeration and process cooling applications. Motor, scroll and bearing are optimized for high seasonal efficiency, which helps end user reduce life cycle cost all year round.

Multiple refrigerants

ZB compressors are approved for R404A, R507, R22, R134a, R407F, R448A and R449A refrigerants.

Nomenclature

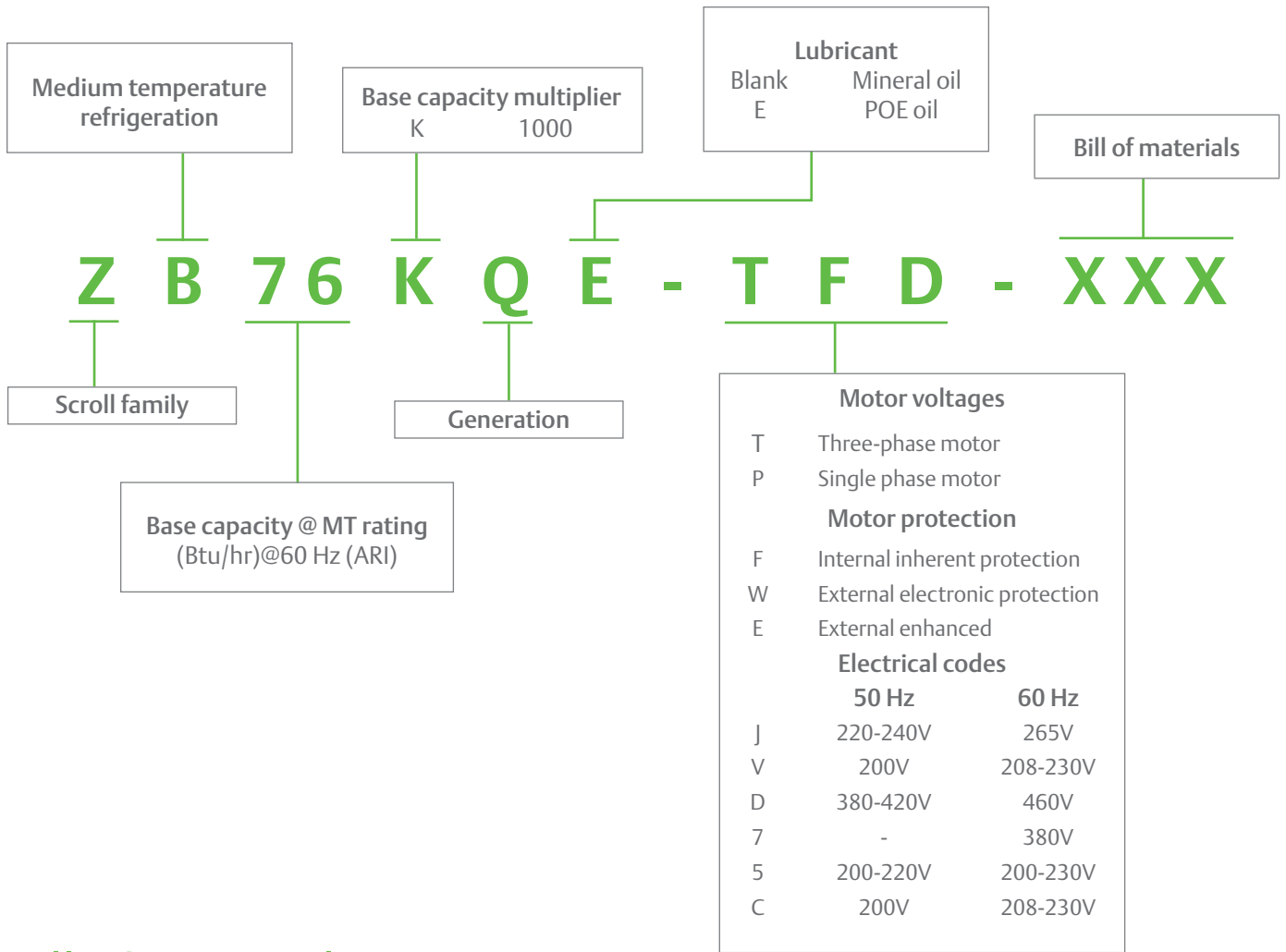

Bill of material

Compressor model	Motor code	BOM number	Stub tube connection	Rotalock connection	Oil sight glass	Schrader valve
ZB15KQ/E ZB19KQ/E ZB21KQ/E ZB29KQ/E ZB38KQ/E ZB45KQ/E ZB48KQ/E	TFD, TF5, TF7, PFV, PFJ	558	✓		✓	
		559		✓	✓	
ZB58KQ/E ZB66KQ/E ZB76KQ/E ZB88KQ ZB95KQ/E ZB114KQ/E	TFD, TF5, TF7 (TW5/7 for ZB95/114)	550	✓		✓	✓
		551		✓	✓	✓
ZB130KQ/E	TED, TE7, TEC	550	✓		✓	✓
		551		✓	✓	✓
ZB150KQ/E ZB190KQ/E ZB220KQ/E	TWD, TW7, TWC	522	✓		✓	✓
		523		✓	✓	✓

(1) PFJ is available for ZB15-ZB29 only
 (2) PFV is available for ZB15-ZB38 only

Operating envelopes

ZB15KQE~ZB76KQE

R404A

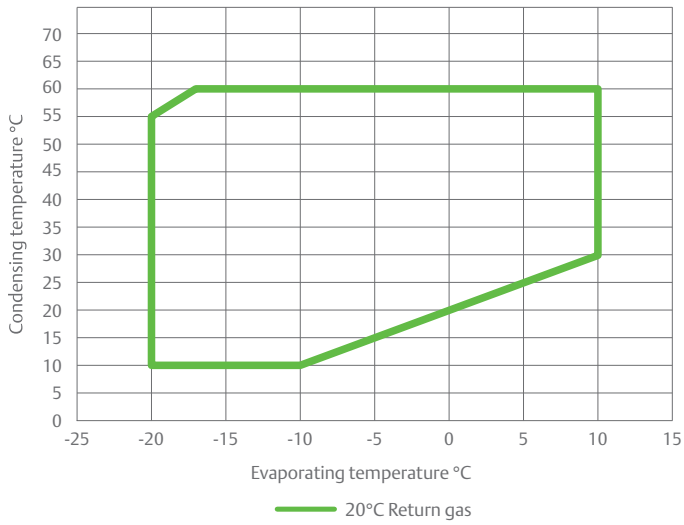

ZB95KQE~ZB114KQE, ZB130KQE

R404A

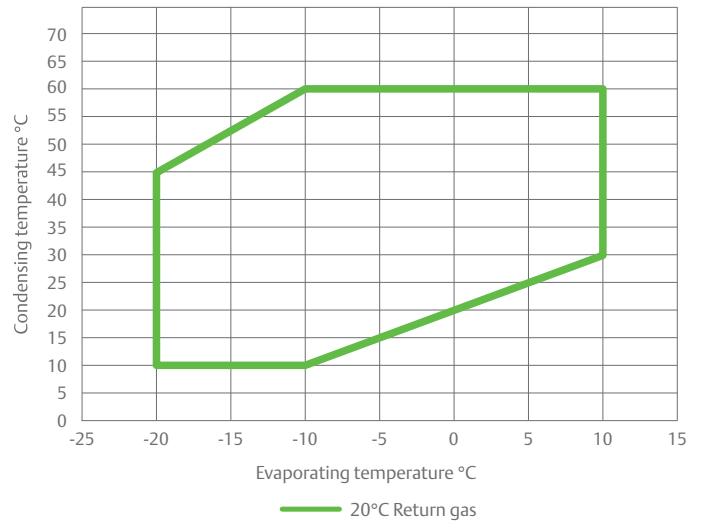

ZB190KQE~ZB220KQE

R404A

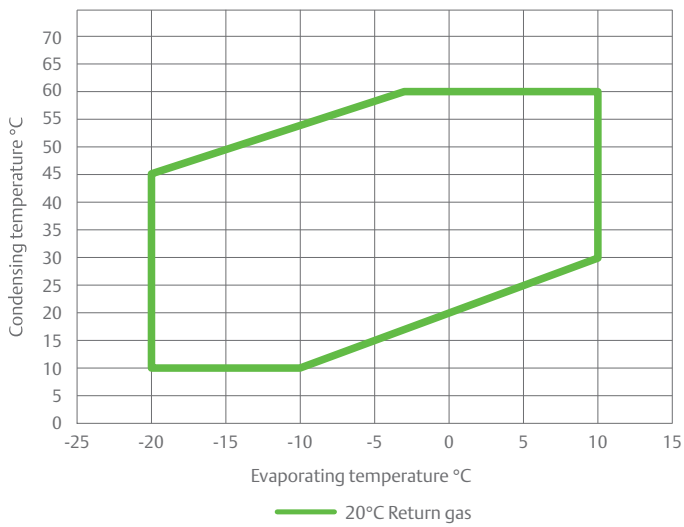

ZB15KQE~ZB76KQE, ZB130KQE~ZB220KQE

R134a

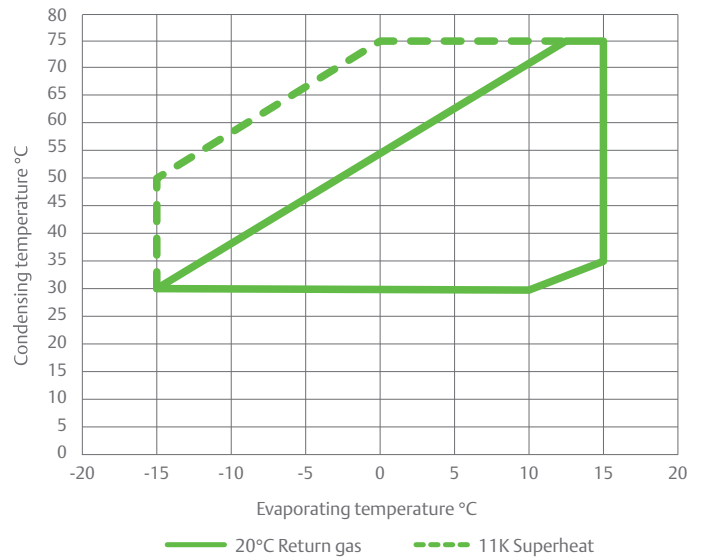

Operating envelopes

ZB15KQ~ZB88KQ, ZB130KQ~ZB220KQ R22

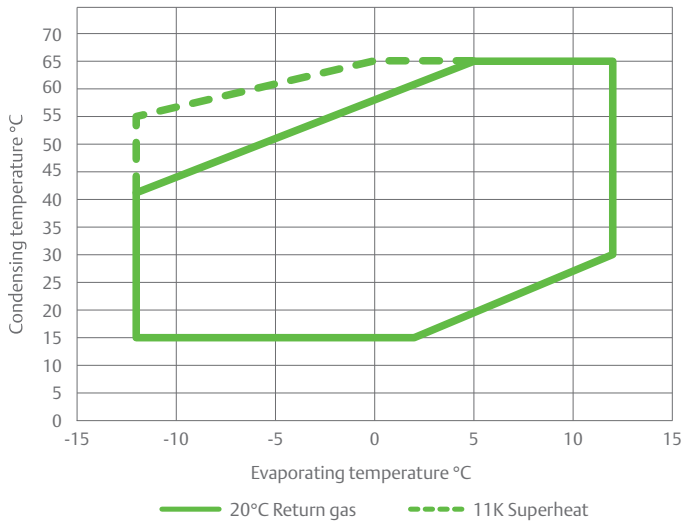

ZB95KQ~ZB114KQ (TFD only) R22

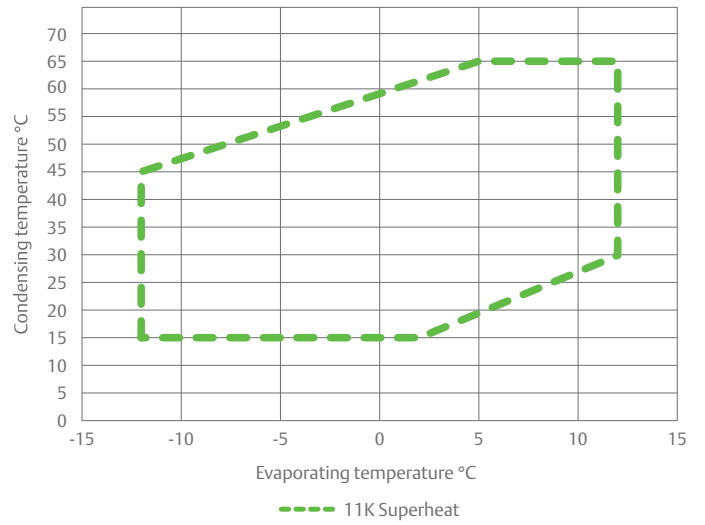

ZB95KQ~ZB114KQ (TW7/TW5) R22

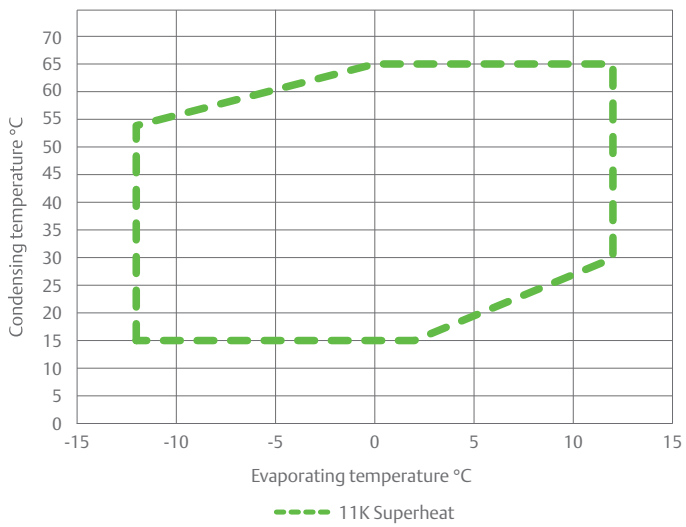

Product line-up

Capacity, kW

R404A - 50 Hz

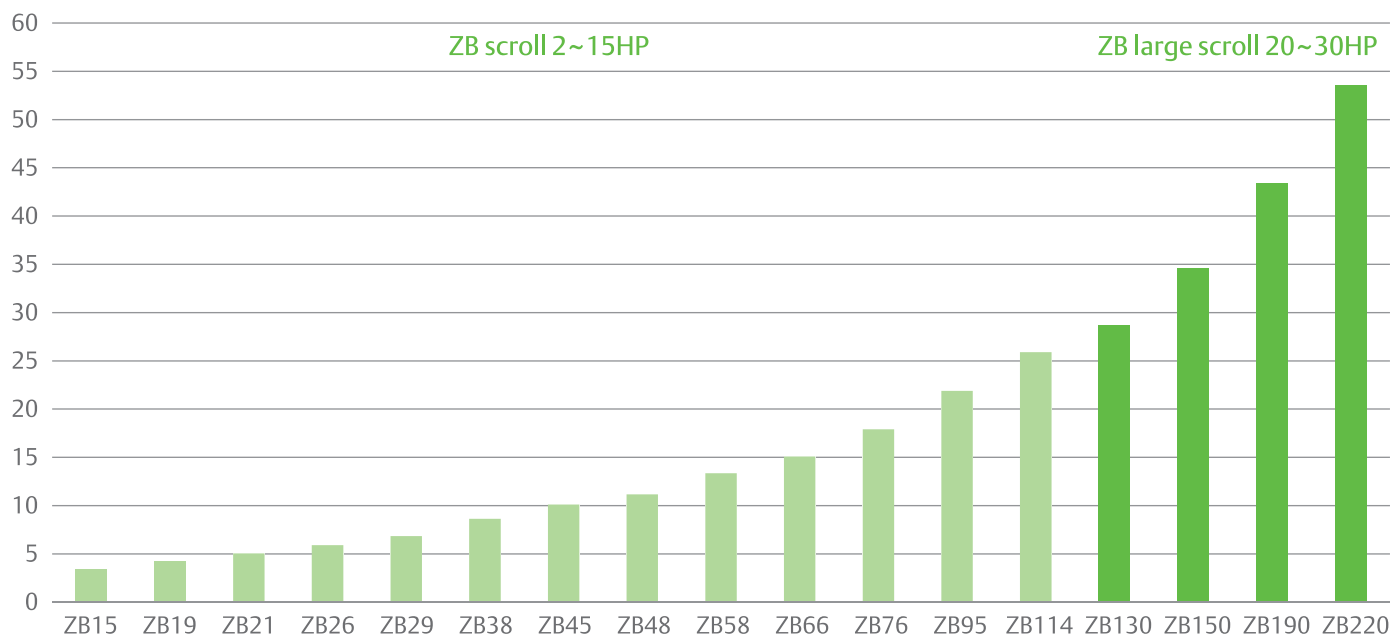

Capacity, kW

R404A - 60 Hz

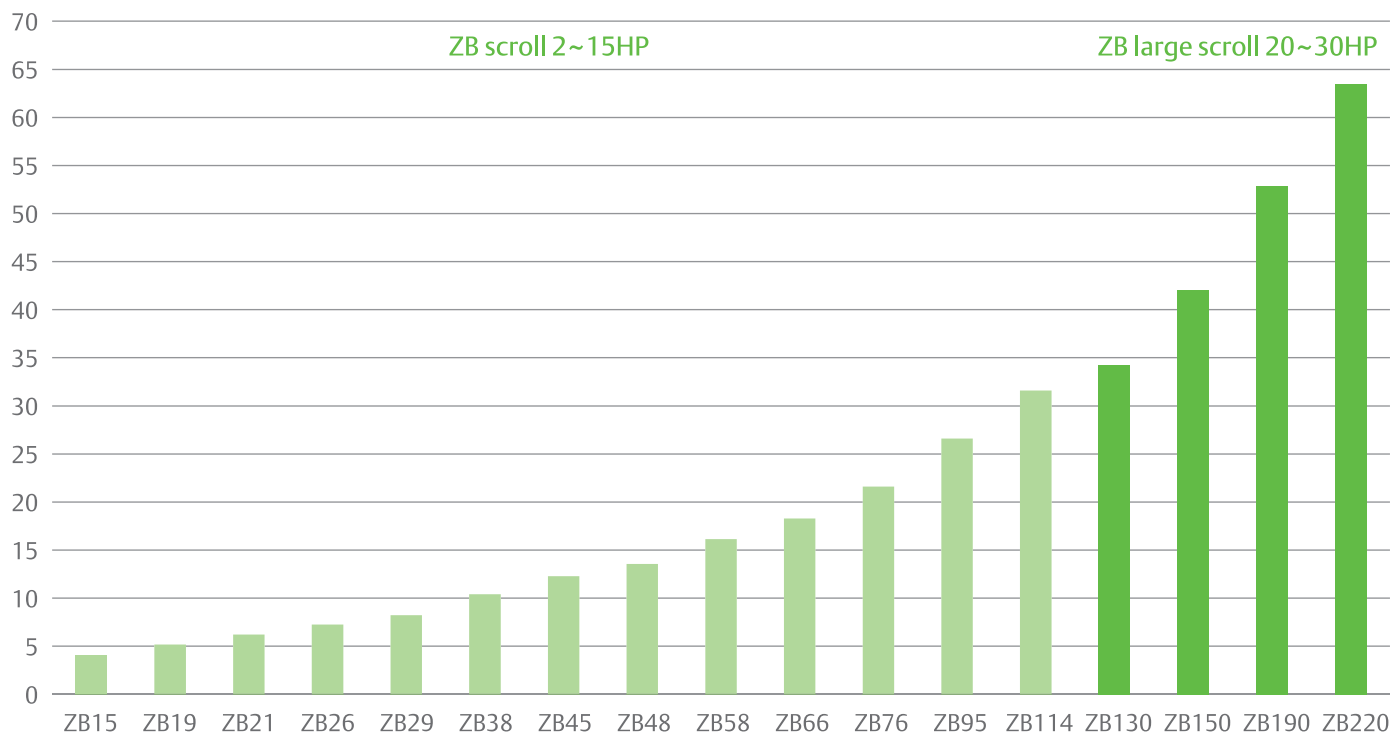

Notes: Based on medium temperature cold room conditions: -10°C evaporating, 45°C condensing, 20°C return gas, 0K sub-cooling

Performance data

Q=Capacity (kW) P=Power input (kW) 1-Phase

R22
50 Hz

Model		Condensing temperature °C	Evaporating temperature (°C)						
			-12	-10	-5	0	5	10	12.5
ZB15KQ	Q	15	4.0	4.4	5.3	6.3			
		20	3.9	4.2	5.1	6.1	7.2		
		30	3.6	3.9	4.7	5.6	6.7	7.9	8.6
		40	3.3	3.5	4.3	5.2	6.1	7.3	7.9
		50	2.7	2.9	3.9	4.6	5.5	6.6	7.2
		55		2.7	3.4	4.4	5.2	6.2	6.8
		60			3.2	3.9	4.9	5.8	6.4
	65				3.6	4.5	5.4	5.9	
	P	15	0.9	0.9	0.9	0.9			
		20	1.0	1.0	1.0	1.0	1.0		
		30	1.2	1.2	1.2	1.2	1.2	1.2	1.2
		40	1.4	1.4	1.4	1.4	1.4	1.4	1.4
		50	1.7	1.7	1.7	1.7	1.7	1.7	1.7
		55		1.9	1.9	1.9	1.9	1.9	1.9
60				2.1	2.1	2.1	2.1	2.1	
65				2.4	2.3	2.3	2.3		
ZB19KQ	Q	15	4.7	5.0	6.1	7.3			
		20	4.5	4.8	5.9	7.0	8.3		
		30	4.1	4.5	5.4	6.5	7.7	9.1	9.9
		40	3.7	4.1	4.9	5.9	7.1	8.4	9.1
		50	3.1	3.4	4.4	5.3	6.4	7.6	8.3
		55		3.1	3.9	5.0	6.0	7.2	7.8
		60			3.6	4.5	5.6	6.7	7.4
	65				4.2	5.2	6.3	6.8	
	P	15	1.0	1.0	1.0	1.0			
		20	1.1	1.1	1.1	1.1	1.1		
		30	1.3	1.3	1.3	1.3	1.3	1.3	1.3
		40	1.6	1.6	1.6	1.6	1.6	1.6	1.6
		50	1.9	1.9	1.9	1.9	1.9	1.9	1.9
		55		2.2	2.1	2.1	2.1	2.1	2.1
60				2.4	2.4	2.4	2.4	2.3	
65				2.7	2.6	2.6	2.6		
ZB21KQ	Q	15	5.9	6.3	7.7	9.1			
		20	5.6	6.1	7.4	8.8	10.5		
		30	5.2	5.6	6.8	8.2	9.7	11.5	12.5
		40	4.7	5.1	6.2	7.5	8.9	10.6	11.5
		50	3.9	4.2	5.6	6.7	8.0	9.6	10.4
		55		4.0	4.9	6.3	7.6	9.0	9.9
		60			4.6	5.7	7.1	8.5	9.3
	65				5.2	6.6	7.9	8.6	
	P	15	1.4	1.4	1.4	1.4			
		20	1.5	1.5	1.5	1.5	1.6		
		30	1.8	1.8	1.8	1.8	1.8	1.9	1.9
		40	2.2	2.2	2.2	2.2	2.2	2.2	2.2
		50	2.7	2.7	2.7	2.7	2.7	2.7	2.7
		55		3.0	3.0	3.0	3.0	3.0	2.9
60				3.3	3.3	3.3	3.3	3.3	
65				3.7	3.7	3.6	3.6		

*20°C Return gas temperature in non-shaded region

*11K Suction superheat in shaded region

*0K Subcooling

Performance data

Q=Capacity (kW) P=Power input (kW) 1-Phase

R22
50 Hz

Model		Condensing temperature °C	Evaporating temperature (°C)						
			-12	-10	-5	0	5	10	12.5
ZB26KQ	Q	15	6.8	7.3	8.8	10.5			
		20	6.5	7.0	8.5	10.2	12.1		
		30	6.0	6.5	7.9	9.4	11.2	13.3	14.5
		40	5.4	5.9	7.2	8.6	10.3	12.2	13.3
		50	4.4	4.9	6.4	7.8	9.3	11.0	12.1
		55		4.6	5.7	7.3	8.7	10.4	11.4
		60			5.3	6.6	8.2	9.8	10.7
	65				6.0	7.6	9.1	10.0	
	P	15	1.5	1.5	1.5	1.5			
		20	1.6	1.6	1.6	1.6	1.7		
		30	1.9	1.9	1.9	2.0	2.0	2.0	2.0
		40	2.4	2.4	2.3	2.4	2.4	2.4	2.4
		50	2.9	2.9	2.9	2.9	2.9	2.9	2.9
		55		3.2	3.2	3.2	3.2	3.2	3.2
60				3.6	3.6	3.5	3.5	3.5	
65				4.0	3.9	3.9	3.9		
ZB29KQ	Q	15	7.9	8.6	10.3	12.1			
		20	7.6	8.3	10.0	11.8	13.8		
		30	7.0	7.7	9.3	11.1	13.1	15.4	16.7
		40	6.4	7.0	8.5	10.2	12.1	14.3	15.6
		50	5.4	5.9	7.7	9.2	10.9	13.0	14.3
		55		5.7	6.9	8.6	10.3	12.3	13.5
		60			6.5	7.8	9.6	11.5	12.7
	65				7.4	9.0	10.8	11.8	
	P	15	1.6	1.7	1.7	1.8			
		20	1.8	1.8	1.9	1.9	1.9		
		30	2.1	2.1	2.2	2.2	2.3	2.3	2.3
		40	2.5	2.5	2.6	2.6	2.7	2.7	2.7
		50	3.0	3.1	3.1	3.1	3.2	3.2	3.2
		55		3.3	3.4	3.4	3.5	3.5	3.5
60				3.7	3.8	3.8	3.8	3.9	
65				4.2	4.2	4.2	4.2		

*20°C Return gas temperature in non-shaded region

* 11K Suction superheat in shaded region

*0K Subcooling

Performance data

Q=Capacity (kW) P=Power input (kW) 3-Phase

R22

50 Hz

Model		Condensing temperature °C	Evaporating temperature (°C)						
			-12	-10	-5	0	5	10	12.5
ZB15KQ	Q	15	4.1	4.4	5.3	6.2			
		20	3.9	4.3	5.1	6.1	7.2		
		30	3.6	3.9	4.7	5.7	6.7	7.9	8.5
		40	3.2	3.5	4.3	5.2	6.1	7.3	7.9
		50	2.7	2.9	3.8	4.6	5.5	6.5	7.1
		55		2.7	3.4	4.3	5.1	6.1	6.7
		60			3.1	3.9	4.8	5.7	6.2
	P	15	0.8	0.8	0.8	0.8			
		20	0.9	0.9	0.9	0.9	1.0		
		30	1.1	1.1	1.1	1.1	1.2	1.2	1.2
		40	1.4	1.4	1.4	1.4	1.4	1.4	1.4
		50	1.7	1.7	1.7	1.7	1.7	1.8	1.7
		55		1.9	1.9	1.9	1.9	1.9	1.9
		60			2.1	2.1	2.2	2.2	2.2
ZB19KQ	Q	15	4.7	5.1	6.1	7.2			
		20	4.5	4.9	5.9	7.0	8.2		
		30	4.1	4.5	5.5	6.5	7.7	9.1	9.8
		40	3.7	4.1	4.9	5.9	7.1	8.4	9.1
		50	3.1	3.3	4.4	5.3	6.3	7.5	8.2
		55		3.1	3.9	5.0	5.9	7.1	7.7
		60			3.6	4.4	5.5	6.6	7.2
	P	15	0.9	0.9	0.9	0.9			
		20	1.0	1.0	1.0	1.0	1.1		
		30	1.2	1.2	1.3	1.3	1.3	1.3	1.3
		40	1.5	1.5	1.6	1.6	1.6	1.6	1.6
		50	1.9	1.9	1.9	2.0	2.0	2.0	2.0
		55		2.1	2.2	2.2	2.2	2.2	2.2
		60			2.4	2.4	2.5	2.5	2.5
ZB21KQ	Q	15	5.9	6.4	7.7	9.1			
		20	5.7	6.2	7.4	8.8	10.4		
		30	5.2	5.7	6.9	8.2	9.7	11.5	12.4
		40	4.7	5.1	6.2	7.5	8.9	10.5	11.5
		50	3.8	4.2	5.5	6.7	8.0	9.5	10.3
		55		3.9	4.9	6.2	7.5	8.9	9.7
		60			4.6	5.6	6.9	8.3	9.1
	P	15	1.2	1.2	1.2	1.2			
		20	1.3	1.3	1.3	1.4	1.4		
		30	1.6	1.6	1.6	1.7	1.7	1.7	1.7
		40	2.0	2.0	2.0	2.0	2.1	2.1	2.1
		50	2.5	2.5	2.5	2.5	2.6	2.6	2.6
		55		2.8	2.8	2.8	2.9	2.9	2.9
		60			3.1	3.2	3.2	3.2	3.2
	65				3.5	3.6	3.6	3.5	

*20°C Return gas temperature in non-shaded region

*11K Suction superheat in shaded region

*0K Subcooling

Performance data

Q=Capacity (kW) P=Power input (kW) 3-Phase

R22
50 Hz

Model		Condensing temperature °C	Evaporating temperature (°C)						
			-12	-10	-5	0	5	10	12.5
ZB26KQ	Q	15	6.9	7.5	9.0	10.7			
		20	6.7	7.2	8.7	10.4	12.4		
		30	6.1	6.7	8.1	9.7	11.6	13.9	15.2
		40	5.6	6.1	7.4	8.8	10.6	12.7	14.0
		50	4.6	5.1	6.6	7.9	9.5	11.4	12.6
		55		4.8	5.9	7.4	8.9	10.7	11.8
		60			5.5	6.7	8.3	10.0	11.0
	65				6.2	7.7	9.2	10.2	
	P	15	1.2	1.2	1.2	1.2			
		20	1.4	1.4	1.4	1.4	1.4		
		30	1.7	1.7	1.7	1.7	1.8	1.8	1.7
		40	2.2	2.2	2.2	2.2	2.2	2.2	2.2
		50	2.8	2.8	2.8	2.8	2.8	2.8	2.7
		55		3.2	3.1	3.1	3.1	3.1	3.1
60				3.6	3.6	3.5	3.5	3.4	
65				4.0	4.0	3.9	3.9		
ZB29KQ	Q	15	7.9	8.6	10.3	12.2			
		20	7.6	8.3	9.9	11.8	13.9		
		30	7.0	7.6	9.2	11.0	13.0	15.4	16.6
		40	6.3	6.8	8.3	10.0	11.9	14.1	15.4
		50	5.1	5.6	7.4	8.9	10.7	12.7	13.8
		55		5.3	6.5	8.4	10.0	11.9	13.0
		60			6.1	7.5	9.3	11.1	12.1
	65				6.9	8.6	10.3	11.2	
	P	15	1.5	1.5	1.5	1.6			
		20	1.6	1.6	1.7	1.7	1.8		
		30	2.1	2.0	2.1	2.1	2.2	2.2	2.2
		40	2.5	2.5	2.6	2.6	2.6	2.7	2.7
		50	3.2	3.2	3.2	3.2	3.3	3.3	3.3
		55		3.5	3.6	3.6	3.6	3.7	3.6
60				4.0	4.0	4.1	4.1	4.1	
65				4.5	4.5	4.5	4.5		
ZB38KQ	Q	15	9.8	10.6	12.7	15.1			
		20	9.5	10.2	12.4	14.7	17.3		
		30	8.7	9.4	11.4	13.7	16.2	19.1	20.7
		40	7.8	8.5	10.3	12.4	14.8	17.6	19.1
		50	6.4	7.0	9.2	11.1	13.3	15.8	17.2
		55		6.5	8.1	10.4	12.4	14.8	16.2
		60			7.6	9.3	11.5	13.8	15.1
	65				8.6	10.7	12.8	14.0	
	P	15	1.9	1.9	1.9	2.0			
		20	2.1	2.1	2.1	2.2	2.3		
		30	2.6	2.6	2.6	2.7	2.7	2.8	2.8
		40	3.2	3.2	3.2	3.3	3.3	3.4	3.4
		50	4.0	4.0	4.0	4.1	4.1	4.1	4.1
		55		4.5	4.5	4.5	4.6	4.6	4.6
60				5.0	5.1	5.1	5.1	5.1	
65				5.7	5.7	5.7	5.7		

*20°C Return gas temperature in non-shaded region

*11K Suction superheat in shaded region

*0K Subcooling

Performance data

Q=Capacity (kW) P=Power input (kW) 3-Phase

R22
50 Hz

Model		Condensing temperature °C	Evaporating temperature (°C)						
			-12	-10	-5	0	5	10	12.5
ZB45KQ	Q	15	11.8	12.8	15.4	18.4			
		20	11.4	12.3	14.8	17.7	21.1		
		30	10.5	11.4	13.7	16.4	19.5	23.1	25.1
		40	9.5	10.3	12.5	15.0	17.8	21.1	23.0
		50	7.7	8.4	11.1	13.4	16.0	19.0	20.7
		55		7.8	9.8	12.5	15.0	17.9	19.4
		60			9.0	11.2	14.0	16.7	18.2
	65				10.2	12.8	15.4	16.8	
	P	15	2.1	2.1	2.2	2.2			
		20	2.3	2.4	2.4	2.5	2.6		
		30	3.0	3.0	3.0	3.1	3.1	3.2	3.2
		40	3.7	3.7	3.8	3.8	3.8	3.9	3.9
		50	4.7	4.7	4.7	4.7	4.7	4.8	4.8
		55		5.2	5.3	5.3	5.3	5.3	5.3
60				5.9	5.9	5.9	5.9	5.9	
65				6.6	6.6	6.6	6.6		
ZB48KQ	Q	15	13.0	14.0	16.9	20.2			
		20	12.5	13.5	16.3	19.5	23.2		
		30	11.5	12.5	15.1	18.1	21.5	25.4	27.6
		40	10.4	11.3	13.7	16.5	19.6	23.2	25.3
		50	8.4	9.3	12.2	14.7	17.6	20.9	22.7
		55		8.6	10.8	13.8	16.5	19.6	21.4
		60			9.9	12.3	15.4	18.3	20.0
	65				11.2	14.1	16.9	18.5	
	P	15	2.3	2.3	2.4	2.5			
		20	2.6	2.6	2.7	2.7	2.8		
		30	3.3	3.3	3.3	3.4	3.4	3.5	3.6
		40	4.1	4.1	4.1	4.2	4.2	4.2	4.3
		50	5.1	5.1	5.2	5.2	5.2	5.2	5.2
		55		5.8	5.8	5.8	5.8	5.8	5.8
60				6.5	6.5	6.5	6.5	6.5	
65				7.3	7.2	7.2	7.2		
ZB58KQ	Q	15	15.4	16.7	20.2	24.2			
		20	14.7	15.9	19.4	23.3	27.8		
		30	13.3	14.5	17.8	21.5	25.7	30.5	33.2
		40	11.9	13.0	16.1	19.6	23.6	28.1	30.5
		50	9.3	10.4	14.2	17.5	21.2	25.3	27.6
		55		9.3	12.3	16.2	19.8	23.8	26.0
		60			11.0	14.3	18.3	22.2	24.3
	65				12.8	16.6	20.3	22.4	
	P	15	2.7	2.8	2.8	2.9			
		20	3.1	3.1	3.2	3.2	3.3		
		30	3.9	3.9	3.9	4.0	4.1	4.2	4.3
		40	4.9	4.9	4.9	4.9	5.0	5.1	5.1
		50	6.1	6.1	6.1	6.1	6.1	6.2	6.2
		55		6.9	6.9	6.8	6.8	6.9	6.9
60				7.7	7.7	7.6	7.7	7.7	
65				8.6	8.6	8.5	8.6		

*20°C Return gas temperature in non-shaded region

*11K Suction superheat in shaded region

*0K Subcooling

Performance data

Q=Capacity (kW) P=Power input (kW) 3-Phase

R22
50 Hz

Model		Condensing temperature °C	Evaporating temperature (°C)						
			-12	-10	-5	0	5	10	12.5
ZB66KQ	Q	15	17.2	18.7	22.6	27.2			
		20	16.6	18.0	21.8	26.2	31.2		
		30	15.3	16.6	20.1	24.2	28.9	34.2	37.1
		40	14.0	15.2	18.5	22.2	26.5	31.4	34.1
		50	11.4	12.5	16.6	20.1	24.0	28.4	30.9
		55		11.6	14.7	18.8	22.6	26.8	29.2
		60			13.5	16.9	21.1	25.1	27.3
	65				15.5	19.5	23.3	25.4	
	P	15	2.8	2.9	2.9	3.0			
		20	3.3	3.4	3.4	3.5	3.6		
		30	4.3	4.3	4.4	4.4	4.5	4.7	4.8
		40	5.3	5.4	5.4	5.5	5.6	5.7	5.8
		50	6.7	6.7	6.7	6.8	6.8	6.9	7.0
		55		7.6	7.6	7.6	7.6	7.7	7.7
60				8.5	8.5	8.5	8.5	8.6	
65				9.6	9.6	9.6	9.6		
ZB76KQ	Q	15	20.3	22.0	26.8	32.3			
		20	19.5	21.2	25.7	31.0	36.9		
		30	18.0	19.5	23.7	28.6	34.0	40.2	43.5
		40	16.4	17.9	21.8	26.2	31.2	36.9	39.9
		50	13.4	14.7	19.5	23.6	28.2	33.4	36.2
		55		13.6	17.2	22.2	26.6	31.5	34.2
		60			15.8	19.9	24.9	29.6	32.1
	65				18.2	23.0	27.5	29.9	
	P	15	3.0	3.0	3.1	3.1			
		20	3.7	3.7	3.8	3.8	4.0		
		30	5.0	5.0	5.0	5.1	5.2	5.5	5.6
		40	6.3	6.3	6.4	6.4	6.5	6.7	6.8
		50	7.9	8.0	8.0	8.0	8.1	8.2	8.3
		55		9.0	9.0	9.0	9.1	9.2	9.2
60				10.2	10.2	10.2	10.2	10.3	
65				11.6	11.6	11.5	11.6		
ZB88KQ	Q	15	23.6	25.4	30.5	36.2			
		20	22.7	24.6	29.6	35.2	41.3		
		30	20.9	22.6	27.5	32.9	38.9	45.4	48.8
		40	18.8	20.4	25.0	30.1	35.8	42.0	45.3
		50	15.1	16.6	22.1	26.8	32.1	38.0	41.1
		55		15.3	19.3	25.0	30.0	35.7	38.7
		60			17.7	22.2	27.8	33.2	36.1
	65				20.1	25.4	30.5	33.2	
	P	15	3.9	4.0	4.1	4.4			
		20	4.5	4.5	4.6	4.8	5.1		
		30	5.7	5.7	5.8	5.9	6.1	6.4	6.6
		40	7.1	7.2	7.2	7.3	7.4	7.6	7.8
		50	8.9	9.0	9.0	9.1	9.2	9.3	9.4
		55		10.0	10.1	10.2	10.2	10.3	10.4
60				11.3	11.4	11.4	11.5	11.5	
65				12.7	12.7	12.8	12.8		

*20°C Return gas temperature in non-shaded region

*11K Suction superheat in shaded region

*0K Subcooling

Performance data

Q=Capacity (kW) P=Power input (kW) 3-Phase

R22
50 Hz

Model		Condensing temperature °C	Evaporating temperature (°C)						
			-12	-10	-5	0	5	10	12.5
ZB95KQ	Q	15	25.4	27.4	33.2	40.0			
		20	24.4	26.4	31.8	38.2	45.6		
		30	22.4	24.2	29.4	35.2	41.8	49.4	53.6
		40	19.6	21.5	26.5	32.1	38.3	45.2	49.0
		50			22.5	28.1	34.1	40.7	44.3
		55				25.4	31.5	38.0	41.5
		60					28.4	34.9	38.4
	65					24.6	31.3	34.8	
	P	15	4.7	4.7	5.0	5.3			
		20	5.2	5.2	5.4	5.7	6.0		
		30	6.5	6.5	6.6	6.7	6.9	7.2	7.4
		40	8.0	8.1	8.2	8.3	8.4	8.5	8.6
		50			10.1	10.2	10.3	10.4	10.4
		55				11.4	11.5	11.5	11.5
60						12.7	12.8	12.8	
65					14.0	14.1	14.2		
ZB114KQ	Q	15	30.5	33.0	39.7	47.3			
		20	29.4	31.8	38.4	45.9	54.3		
		30	26.8	29.1	35.4	42.5	50.5	59.4	64.2
		40	23.2	25.6	31.7	38.6	46.1	54.5	59.1
		50			27.1	33.7	41.0	49.0	53.3
		55				30.9	38.1	45.9	50.1
		60					34.9	42.5	46.6
	65					31.4	38.9	42.9	
	P	15	5.7	5.8	6.0	6.3			
		20	6.3	6.4	6.6	6.8	7.1		
		30	7.8	7.8	7.9	8.1	8.3	8.6	8.8
		40	9.6	9.6	9.7	9.8	10.0	10.2	10.4
		50			12.0	12.1	12.2	12.3	12.4
		55				13.5	13.5	13.6	13.7
60						15.0	15.1	15.2	
65					16.7	16.8	16.8		

*20°C Return gas temperature in non-shaded region

*11K Suction superheat in shaded region

*0K Subcooling

Performance data

Q=Capacity (kW) P=Power input (kW) 3-Phase

R22
50 Hz

Model		Condensing temperature °C	Evaporating temperature (°C)						
			-12	-10	-5	0	5	10	12
ZB130KQ	Q	15	33.7	36.4	43.9	52.5			
		20	32.2	34.8	42.1	50.4	60.0		
		25	30.7	33.3	40.4	48.5	57.7		
		30	29.2	31.8	38.7	46.6	55.5	65.5	69.9
		35	27.7	30.2	37.0	44.7	53.3	62.9	67.0
		40	26.1	28.5	35.2	42.7	51.0	60.2	64.1
		45	24.1	26.6	33.3	40.5	48.5	57.4	61.1
		50	21.9	24.4	31.1	38.2	45.9	54.3	58.0
		55	19.3	21.8	28.4	35.5	43.0	51.1	54.5
	60			25.4	32.3	39.7	47.5	50.8	
	65				28.7	36.0	43.5	46.6	
	P	15	5.8	5.8	5.9	6.1			
		20	6.6	6.6	6.8	6.9	7.1		
		25	7.4	7.4	7.6	7.8	8.0		
		30	8.2	8.3	8.4	8.6	8.8	9.0	9.1
		35	9.2	9.2	9.4	9.5	9.7	9.9	10.0
		40	10.1	10.2	10.3	10.5	10.7	10.9	11.0
		45	11.2	11.3	11.4	11.6	11.8	12.0	12.0
50		12.4	12.5	12.6	12.8	13.0	13.1	13.2	
55		13.7	13.8	14.0	14.1	14.3	14.5	14.5	
60			15.5	15.6	15.8	16.0	16.0		
65				17.3	17.5	17.7	17.7		
ZB150KQ	Q	15	40.1	43.3	52.4	63.3			
		20	38.1	41.1	49.7	59.9	72.0		
		25	36.4	39.3	47.4	57.0	68.3		
		30	34.8	37.6	45.4	54.5	65.1	77.6	83.2
		35	33.2	36.0	43.5	52.1	62.2	74.0	79.3
		40	31.5	34.2	41.6	49.9	59.5	70.6	75.6
		45	29.3	32.1	39.5	47.6	56.8	67.4	72.1
		50	26.8	29.6	37.2	45.1	53.9	64.1	68.6
		55	23.7	26.6	34.1	42.3	50.9	60.7	65.0
	60			30.7	38.7	47.5	57.0	61.1	
	65				34.7	43.6	52.9	56.9	
	P	15	7.2	7.3	7.5	7.7			
		20	8.2	8.3	8.5	8.8	9.0		
		25	9.3	9.4	9.5	9.8	10.0		
		30	10.4	10.4	10.6	10.8	11.0	11.3	11.4
		35	11.5	11.6	11.7	11.9	12.1	12.3	12.4
		40	12.7	12.8	12.9	13.1	13.3	13.5	13.5
		45	14.1	14.2	14.3	14.5	14.6	14.8	14.8
50		15.7	15.8	15.9	16.0	16.1	16.3	16.3	
55		17.5	17.6	17.7	17.8	17.9	18.0	18.1	
60			19.8	19.9	19.9	20.0	20.1		
65				22.2	22.3	22.4	22.4		

*20°C Return gas temperature in non-shaded region

*11K Suction superheat in shaded region

*0K Subcooling

Performance data

Q=Capacity (kW) P=Power input (kW) 3-Phase

R22
50 Hz

Model		Condensing temperature °C	Evaporating temperature (°C)						
			-12	-10	-5	0	5	10	12
ZB190KQ	Q	15	47.4	51.1	61.6	73.8			
		20	45.9	49.7	60.0	72.0	85.8		
		25	44.3	48.0	58.2	69.9	83.4		
		30	42.5	46.1	56.0	67.5	80.7	95.8	102.4
		35	40.5	44.0	53.7	64.9	77.7	92.4	98.8
		40	38.3	41.7	51.1	62.0	74.4	88.7	94.9
		45	35.8	39.1	48.4	58.8	70.8	84.6	90.7
		50	33.2	36.4	45.4	55.4	67.0	80.3	86.1
		55	30.5	33.5	41.9	51.9	62.9	75.7	81.3
	60			38.5	47.7	58.6	70.8	76.1	
	65				43.7	54.1	65.6	70.7	
	P	15	8.9	9.0	9.4	10.0			
		20	10.0	10.1	10.4	10.8	11.5		
		25	11.2	11.2	11.5	11.8	12.4		
		30	12.6	12.6	12.7	13.0	13.5	14.2	14.6
		35	14.1	14.1	14.2	14.4	14.8	15.4	15.7
		40	15.9	15.8	15.9	16.0	16.3	16.9	17.1
		45	17.8	17.8	17.7	17.8	18.1	18.5	18.8
50		20.0	19.9	19.9	19.9	20.1	20.4	20.6	
55		22.4	22.3	22.2	22.2	22.3	22.6	22.8	
60			24.8	24.8	24.9	25.1	25.2		
65				27.6	27.7	27.8	28.0		
ZB220KQ	Q	15	58.9	63.4	75.9	90.5			
		20	57.5	61.9	74.1	88.2	104.6		
		25	55.8	60.1	72.0	85.7	101.6		
		30	53.8	58.1	69.7	83.0	98.3	115.8	123.5
		35	51.5	55.8	67.2	80.1	94.9	111.7	119.1
		40	48.9	53.1	64.4	77.0	91.2	107.4	114.5
		45	45.7	49.9	61.2	73.5	87.3	102.9	109.7
		50	42.1	46.3	57.7	69.7	83.1	98.1	104.6
		55	37.9	42.2	53.3	65.6	78.5	93.0	99.2
	60			48.8	60.6	73.6	87.5	93.5	
	65				55.4	68.3	81.7	87.5	
	P	15	11.2	11.4	11.9	12.6			
		20	12.5	12.6	13.0	13.6	14.4		
		25	13.9	14.0	14.3	14.8	15.5		
		30	15.4	15.5	15.8	16.2	16.8	17.5	17.9
		35	17.1	17.2	17.5	17.8	18.3	19.0	19.3
		40	19.0	19.1	19.4	19.7	20.1	20.7	20.9
		45	24.1	26.6	33.3	40.5	22.2	22.7	22.9
50		21.9	24.4	31.1	38.2	24.5	24.9	25.2	
55		19.3	21.8	28.4	35.5	27.0	27.5	27.7	
60			25.4	32.3	29.8	30.3	30.5		
65				28.7	32.9	33.5	33.7		

*20°C Return gas temperature in non-shaded region

*11K Suction superheat in shaded region

*0K Subcooling

Performance data

Q=Capacity (kW) P=Power input (kW) 1-Phase

R404A

50 Hz

Model		Condensing temperature °C	Evaporating temperature (°C)						
			-20	-15	-10	-5	0	5	10
ZB15KQE	Q	10	3.7	4.5	5.5				
		20	3.4	4.1	4.9	5.9	7.0		
		30	3.0	3.6	4.4	5.3	6.2	7.3	8.6
		40	2.6	3.2	3.8	4.6	5.4	6.4	7.5
		50	2.2	2.6	3.2	3.8	4.5	5.4	6.3
	P	60		2.1	2.5	3.0	3.6	4.3	5.1
		10	0.7	0.7	0.7				
		20	0.9	0.9	0.9	0.9	0.9		
		30	1.2	1.2	1.2	1.2	1.2	1.2	1.1
		40	1.4	1.5	1.5	1.5	1.5	1.5	1.4
ZB19KQE	Q	50	1.8	1.8	1.8	1.8	1.8	1.8	1.8
		60		2.3	2.3	2.3	2.3	2.3	2.2
		10	4.2	5.1	6.2				
		20	3.9	4.7	5.7	6.8	8.2		
		30	3.5	4.2	5.1	6.1	7.3	8.6	10.1
	P	40	3.0	3.7	4.4	5.3	6.3	7.5	8.8
		50	2.5	3.0	3.7	4.4	5.3	6.2	7.3
		60		2.4	2.9	3.4	4.1	4.9	5.8
		10	0.9	0.9	0.9				
		20	1.1	1.1	1.1	1.1	1.1		
ZB21KQE	Q	30	1.4	1.4	1.4	1.4	1.4	1.4	1.4
		40	1.8	1.8	1.8	1.8	1.8	1.8	1.8
		50	2.3	2.3	2.3	2.3	2.3	2.2	2.2
		60		2.9	2.9	2.9	2.9	2.8	2.8
		10	5.4	6.6	8.0				
	P	20	4.9	6.0	7.3	8.7	10.4		
		30	4.4	5.4	6.5	7.8	9.3	11.0	12.9
		40	3.8	4.7	5.6	6.8	8.1	9.5	11.2
		50	3.2	3.9	4.7	5.6	6.7	8.0	9.4
		60		3.0	3.6	4.4	5.3	6.3	7.4
ZB26KQE	Q	10	1.2	1.2	1.2				
		20	1.5	1.5	1.5	1.5	1.5		
		30	1.8	1.8	1.8	1.8	1.8	1.8	1.8
		40	2.3	2.3	2.3	2.3	2.3	2.3	2.2
		50	2.9	2.9	2.9	2.9	2.9	2.9	2.8
	P	60		3.7	3.7	3.7	3.6	3.6	3.6
		10	6.0	7.3	8.9				
		20	5.4	6.6	8.1	9.8	11.8		
		30	4.7	5.8	7.1	8.7	10.4	12.5	14.8
		40	4.0	4.9	6.1	7.4	9.0	10.8	12.9
ZB29KQE	Q	50	3.1	3.9	4.9	6.0	7.4	8.9	10.8
		60		2.8	3.6	4.5	5.7	7.0	8.5
		10	1.5	1.5	1.4				
		20	1.9	1.9	1.8	1.8	1.7		
		30	2.4	2.3	2.3	2.2	2.2	2.1	2.0
	P	40	3.0	3.0	2.9	2.8	2.7	2.6	2.5
		50	3.8	3.7	3.6	3.6	3.4	3.3	3.2
		60		4.7	4.6	4.5	4.4	4.2	4.0
		10	7.1	8.7	10.6				
		20	6.5	7.9	9.6	11.6	13.8		
ZB29KQE	Q	30	5.7	7.1	8.6	10.3	12.3	14.5	17.0
		40	4.9	6.1	7.4	8.9	10.7	12.6	14.8
		50	4.0	5.0	6.2	7.4	8.9	10.5	12.4
		60		3.8	4.8	5.8	7.0	8.3	9.8
		10	1.6	1.7	1.7				
	P	20	1.9	2.0	2.0	2.0	2.1		
		30	2.3	2.4	2.4	2.4	2.4	2.5	2.5
		40	2.8	2.9	2.9	2.9	2.9	3.0	3.0
		50	3.4	3.5	3.5	3.5	3.5	3.6	3.6
		60		4.2	4.2	4.3	4.3	4.3	4.3

*20°C Return gas temperature in non-shaded region

*11K Suction superheat in shaded region

*0K Subcooling

Performance data

Q=Capacity (kW) P=Power input (kW) 3-Phase

R404A

50 Hz

Model		Condensing temperature °C	Evaporating temperature (°C)						
			-20	-15	-10	-5	0	5	10
ZB15KQE	Q	10	3.7	4.5	5.5				
		20	3.3	4.1	5.0	6.0	7.2		
		30	2.9	3.6	4.4	5.3	6.3	7.5	8.8
		40	2.4	3.0	3.7	4.5	5.4	6.4	7.5
		50	1.9	2.4	3.0	3.6	4.3	5.2	6.1
		60		1.7	2.2	2.7	3.3	3.9	4.6
	P	10	0.8	0.8	0.7				
		20	1.0	1.0	1.0	0.9	0.9		
		30	1.3	1.3	1.2	1.2	1.2	1.2	1.2
		40	1.7	1.6	1.6	1.6	1.5	1.5	1.5
ZB19KQE	Q	10	4.4	5.4	6.5				
		20	4.0	4.9	5.9	7.1	8.5		
		30	3.6	4.4	5.3	6.4	7.6	9.0	10.5
		40	3.1	3.8	4.6	5.5	6.6	7.8	9.2
		50	2.6	3.2	3.8	4.6	5.5	6.5	7.7
		60		2.5	3.0	3.6	4.3	5.1	6.1
	P	10	0.9	0.9	0.9				
		20	1.2	1.2	1.2	1.2	1.2		
		30	1.5	1.5	1.5	1.5	1.5	1.5	1.5
		40	1.9	1.9	1.9	1.9	1.8	1.8	1.8
ZB21KQE	Q	10	5.3	6.4	7.8				
		20	4.8	5.9	7.1	8.6	10.2		
		30	4.3	5.3	6.4	7.6	9.1	10.8	12.6
		40	3.7	4.6	5.5	6.6	7.9	9.3	11.0
		50	3.1	3.8	4.6	5.5	6.6	7.8	9.2
		60		2.9	3.6	4.3	5.2	6.1	7.3
	P	10	1.1	1.1	1.1				
		20	1.4	1.4	1.4	1.4	1.4		
		30	1.8	1.8	1.8	1.8	1.8	1.8	1.7
		40	2.2	2.2	2.2	2.2	2.2	2.2	2.2
ZB26KQE	Q	10	6.1	7.5	9.1				
		20	5.6	6.9	8.3	10.0	11.9		
		30	5.0	6.1	7.4	8.9	10.6	12.6	14.8
		40	4.4	5.3	6.4	7.7	9.2	10.9	12.8
		50	3.6	4.4	5.4	6.4	7.7	9.1	10.7
		60		3.4	4.2	5.0	6.0	7.2	8.5
	P	10	1.3	1.3	1.3				
		20	1.6	1.6	1.6	1.6	1.6		
		30	2.1	2.1	2.1	2.1	2.1	2.0	2.0
		40	2.6	2.6	2.6	2.6	2.6	2.6	2.5
ZB29KQE	Q	10	7.1	8.7	10.6				
		20	6.5	8.0	9.6	11.6	13.8		
		30	5.8	7.1	8.6	10.3	12.3	14.6	17.1
		40	5.1	6.2	7.5	9.0	10.7	12.6	14.9
		50	4.2	5.1	6.2	7.5	8.9	10.6	12.4
		60		4.0	4.8	5.8	7.0	8.3	9.8
	P	10	1.5	1.5	1.5				
		20	1.9	1.9	1.9	1.9	1.9		
		30	2.3	2.4	2.3	2.3	2.3	2.3	2.3
		40	3.0	3.0	3.0	3.0	2.9	2.9	2.9
	50	3.8	3.8	3.7	3.7	3.7	3.7	3.6	
	60		4.8	4.7	4.7	4.7	4.6	4.6	

*20°C Return gas temperature in non-shaded region

*11K Suction superheat in shaded region

*0K Subcooling

Performance data

Q=Capacity (kW) P=Power input (kW) 3-Phase

R404A

50 Hz

Model		Condensing temperature °C	Evaporating temperature (°C)						
			-20	-15	-10	-5	0	5	10
ZB38KQE	Q	10	9.0	11.0	13.3				
		20	8.2	10.0	12.2	14.6	17.4		
		30	7.4	9.0	10.9	13.0	15.5	18.4	21.6
		40	6.4	7.8	9.4	11.3	13.5	15.9	18.7
		50	5.3	6.5	7.8	9.4	11.2	13.3	15.7
		60		5.0	6.1	7.3	8.8	10.5	12.4
	P	10	1.9	1.9	1.9				
		20	2.4	2.4	2.4	2.4	2.4		
		30	3.0	3.0	3.0	3.0	2.9	2.9	2.9
		40	3.7	3.7	3.7	3.7	3.7	3.7	3.6
50		4.7	4.7	4.7	4.7	4.7	4.6	4.6	
60			6.0	6.0	5.9	5.9	5.9	5.8	
ZB45KQE	Q	10	10.5	12.8	15.6				
		20	9.6	11.8	14.2	17.1	20.4		
		30	8.6	10.5	12.7	15.3	18.2	21.5	25.3
		40	7.5	9.1	11.0	13.2	15.8	18.7	21.9
		50	6.2	7.6	9.2	11.0	13.1	15.6	18.4
		60		5.8	7.1	8.6	10.3	12.2	14.5
	P	10	2.1	2.1	2.1				
		20	2.7	2.7	2.7	2.7	2.7		
		30	3.4	3.4	3.4	3.3	3.3	3.3	3.3
		40	4.2	4.2	4.2	4.2	4.2	4.2	4.1
50		5.4	5.4	5.4	5.3	5.3	5.2	5.2	
60			6.8	6.8	6.7	6.7	6.6	6.6	
ZB48KQE	Q	10	11.5	14.1	17.1				
		20	10.6	12.9	15.7	18.8	22.4		
		30	9.5	11.6	14.0	16.8	20.0	23.7	27.8
		40	8.2	10.0	12.1	14.5	17.3	20.5	24.1
		50	6.8	8.3	10.1	12.1	14.4	17.1	20.2
		60		6.4	7.8	9.4	11.3	13.5	16.0
	P	10	2.3	2.3	2.3				
		20	2.9	2.9	2.9	2.9	2.9		
		30	3.7	3.7	3.7	3.7	3.7	3.6	3.6
		40	4.7	4.7	4.7	4.6	4.6	4.6	4.5
50		5.9	5.9	5.9	5.9	5.8	5.8	5.7	
60			7.5	7.4	7.4	7.4	7.3	7.2	
ZB58KQE	Q	10	13.8	16.8	20.3				
		20	12.5	15.3	18.5	22.3	26.6		
		30	11.1	13.7	16.6	20.0	23.8	28.2	33.2
		40	9.5	11.9	14.5	17.5	20.8	24.6	28.9
		50	7.4	9.7	12.0	14.6	17.5	20.7	24.4
		60		6.9	9.0	11.3	13.7	16.4	19.3
	P	10	3.0	3.1	3.1				
		20	3.6	3.7	3.8	3.9	3.9		
		30	4.5	4.5	4.6	4.7	4.7	4.7	4.6
		40	5.6	5.6	5.7	5.7	5.8	5.8	5.7
50		7.2	7.1	7.1	7.1	7.1	7.1	7.1	
60			9.1	9.0	8.9	8.9	8.8	8.7	
ZB66KQE	Q	10	15.7	19.2	23.4				
		20	14.3	17.5	21.2	25.5	30.4		
		30	12.8	15.6	18.8	22.6	26.9	31.9	37.6
		40	11.1	13.5	16.4	19.6	23.3	27.5	32.4
		50	9.1	11.3	13.7	16.4	19.5	23.0	27.0
		60		8.7	10.7	12.9	15.4	18.2	21.4
	P	10	3.4	3.5	3.6				
		20	4.1	4.2	4.3	4.4	4.5		
		30	5.0	5.1	5.2	5.3	5.4	5.5	5.6
		40	6.2	6.3	6.3	6.4	6.5	6.5	6.6
50		7.8	7.9	7.9	7.9	7.9	8.0	8.0	
60			9.9	9.9	9.9	9.8	9.8	9.8	

*20°C Return gas temperature in non-shaded region

*11K Suction superheat in shaded region

*0K Subcooling

Performance data

Q=Capacity (kW) P=Power input (kW) 3-Phase

R404A

50 Hz

Model		Condensing temperature °C	Evaporating temperature (°C)						
			-20	-15	-10	-5	0	5	10
ZB76KQE	Q	10	18.4	22.4	27.2				
		20	16.7	20.4	24.7	29.7	35.5		
		30	14.9	18.3	22.2	26.6	31.7	37.5	44.0
		40	12.9	15.9	19.4	23.3	27.7	32.7	38.3
		50	10.6	13.3	16.2	19.5	23.3	27.5	32.2
		60		10.1	12.6	15.3	18.3	21.8	25.6
	P	10	3.9	4.0	4.1				
		20	4.8	4.9	5.0	5.1	5.1		
		30	5.8	5.9	6.0	6.1	6.2	6.3	6.3
		40	7.2	7.3	7.4	7.5	7.6	7.6	7.7
		50	9.1	9.1	9.2	9.2	9.3	9.3	9.3
		60		11.5	11.4	11.4	11.4	11.4	11.4
ZB95KQE	Q	10	22.8	27.7	33.7				
		20	20.8	25.3	30.5	36.7	43.9		
		30	18.6	22.7	27.4	32.8	39.0	46.2	54.5
		40	15.6	19.6	23.9	28.6	33.9	40.0	47.1
		50		15.5	19.5	23.8	28.4	33.6	39.4
		60			14.0	17.9	21.9	26.3	31.2
	P	10	4.9	5.1	5.2				
		20	6.0	6.1	6.3	6.5	6.6		
		30	7.4	7.5	7.7	7.8	7.9	8.0	8.1
		40	9.4	9.4	9.5	9.6	9.7	9.8	9.8
		50		11.9	11.9	11.9	12.0	12.0	12.0
		60			15.1	15.0	15.0	14.9	14.9
ZB114KQE	Q	10	27.4	33.3	40.3				
		20	24.9	30.4	36.7	44.1	52.5		
		30	21.9	27.0	32.8	39.4	46.8	55.4	65.1
		40	18.3	23.1	28.3	34.1	40.7	48.2	56.7
		50		18.3	23.0	28.2	34.0	40.5	47.8
		60			16.8	21.4	26.4	31.9	38.1
	P	10	5.9	6.1	6.2				
		20	7.2	7.4	7.5	7.7	7.9		
		30	8.9	9.1	9.2	9.3	9.5	9.6	9.8
		40	11.2	11.3	11.3	11.4	11.5	11.6	11.7
		50		14.2	14.2	14.1	14.1	14.1	14.2
		60			17.9	17.7	17.6	17.5	17.4

*20°C Return gas temperature in non-shaded region

*11K Suction superheat in shaded region

*0K Subcooling

Performance data

Q=Capacity (kW) P=Power input (kW) 3-Phase

R404A

50 Hz

Model		Condensing temperature °C	Evaporating temperature (°C)						
			-20	-15	-10	-5	0	5	10
ZB130KQE	Q	10	30.4	36.4	43.6				
		15	28.5	34.3	41.2	49.4			
		20	26.8	32.4	39.0	46.8	55.9		
		25	25.2	30.6	36.9	44.3	52.9	62.8	
		30	23.7	28.9	34.9	41.9	50.0	59.2	69.8
		35	22.2	27.2	32.9	39.5	47.0	55.6	65.5
		40	20.6	25.4	30.8	37.0	44.0	52.0	61.1
		45	19.0	23.6	28.7	34.4	40.9	48.2	56.6
		50		21.6	26.3	31.6	37.6	44.3	51.9
	P	10	5.5	5.6	5.7				
		15	6.4	6.5	6.6	6.7			
		20	7.3	7.4	7.5	7.6	7.8		
		25	8.2	8.3	8.4	8.6	8.7	8.8	
		30	9.1	9.2	9.4	9.5	9.7	9.8	9.8
		35	10.1	10.3	10.4	10.6	10.7	10.8	10.9
		40	11.2	11.4	11.5	11.7	11.8	11.9	12.0
		45	12.5	12.6	12.7	12.9	13.0	13.1	13.2
		50		14.0	14.1	14.2	14.4	14.5	14.5
ZB150KQE	Q	10	35.8	43.6	52.7				
		15	34.2	41.7	50.3	60.3			
		20	32.5	39.7	47.9	57.4	68.2		
		25	30.8	37.6	45.4	54.4	64.6	76.3	
		30	29.1	35.4	42.8	51.3	61.0	72.0	84.4
		35	27.3	33.2	40.1	48.1	57.2	67.5	79.3
		40	25.5	31.0	37.4	44.8	53.3	63.0	74.0
		45	23.7	28.7	34.6	41.4	49.3	58.3	68.6
		50			31.8	38.0	45.2	53.5	63.0
	P	10	7.8	8.2	8.8				
		15	8.6	8.9	9.4	10.1			
		20	9.5	9.7	10.1	10.6	11.4		
		25	10.6	10.7	10.9	11.3	12.0	12.9	
		30	11.7	11.8	12.0	12.3	12.7	13.5	14.5
		35	13.0	13.1	13.2	13.4	13.8	14.3	15.1
		40	14.4	14.5	14.7	14.8	15.1	15.5	16.1
		45	15.9	16.1	16.3	16.4	16.6	16.9	17.4
		50			18.1	18.2	18.4	18.6	19.0
P	55				20.3	20.4	20.6	20.9	
	60					22.7	22.9	23.1	

*20°C Return gas temperature in non-shaded region

*11K Suction superheat in shaded region

*0K Subcooling

Performance data

Q=Capacity (kW) P=Power input (kW) 3-Phase

R404A

50 Hz

Model		Condensing temperature °C	Evaporating temperature (°C)						
			-20	-15	-10	-5	0	5	10
ZB190KQE	Q	10	44.9	54.6	66.0				
		15	42.8	52.2	63.0	75.5			
		20	40.7	49.6	60.0	71.8	85.4		
		25	38.6	47.0	56.8	68.1	80.9	95.5	
		30	36.4	44.3	53.6	64.2	76.3	90.1	105.7
		35	34.2	41.6	50.2	60.2	71.6	84.6	99.3
		40	32.0	38.8	46.8	56.1	66.7	78.9	92.6
		45	29.7	36.0	43.3	51.9	61.7	73.0	85.9
		50			39.8	47.6	56.6	67.0	78.9
	55				43.2	51.4	60.9	71.8	
	60					46.1	54.6	64.5	
	P	10	9.8	10.3	11.1				
		15	10.9	11.2	11.8	12.7			
		20	12.0	12.2	12.7	13.3	14.4		
		25	13.3	13.5	13.8	14.3	15.0	16.2	
		30	14.7	14.9	15.1	15.4	16.0	16.9	18.2
		35	16.3	16.5	16.6	16.9	17.3	18.0	19.0
		40	18.1	18.3	18.4	18.6	18.9	19.4	20.2
45		20.0	20.3	20.5	20.6	20.9	21.2	21.8	
50				22.7	22.9	23.1	23.4	23.8	
55				25.5	25.7	25.9	26.3		
60					28.6	28.8	29.1		
ZB220KQE	Q	10	55.4	67.4	81.4				
		15	52.9	64.4	77.8	93.2			
		20	50.3	61.3	74.0	88.7	105.4		
		25	47.6	58.1	70.1	84.0	99.9	117.9	
		30	45.0	54.7	66.1	79.2	94.2	111.3	130.5
		35	42.2	51.4	62.0	74.3	88.4	104.4	122.5
		40	39.4	47.9	57.8	69.2	82.3	97.3	114.4
		45	36.6	44.4	53.5	64.0	76.2	90.1	106.0
		50			49.1	58.7	69.9	82.7	97.4
	55				53.3	63.4	75.1	88.6	
	60					56.9	67.4	79.7	
	P	10	11.9	12.4	13.4				
		15	13.1	13.5	14.2	15.3			
		20	14.5	14.7	15.2	16.1	17.3		
		25	16.0	16.2	16.6	17.2	18.1	19.5	
		30	17.8	17.9	18.2	18.6	19.3	20.4	21.9
		35	19.7	19.9	20.0	20.4	20.9	21.7	22.9
		40	21.8	22.0	22.2	22.4	22.8	23.4	24.4
45		24.0	24.4	24.6	24.9	25.1	25.6	26.3	
50				27.4	27.6	27.9	28.2	28.7	
55				30.7	30.9	31.2	31.6		
60					34.4	34.7	35.0		

*20°C Return gas temperature in non-shaded region

*11K Suction superheat in shaded region

*0K Subcooling

Performance data

Q=Capacity (kW) P=Power input (kW) 1&3-Phase

R134a

50 Hz

Model		Condensing temperature °C	Evaporating temperature (°C)						
			-15	-10	-5	0	5	10	15
ZB15KQE	Q	30	1.9	2.4	3.0	3.7	4.5	5.4	
		35	1.8	2.3	2.9	3.5	4.3	5.2	
		45	1.6	2.0	2.6	3.2	3.9	4.7	5.6
		55		1.7	2.2	2.7	3.4	4.1	4.9
		65			1.8	2.3	2.9	3.5	4.2
		75				1.9	2.4	3.0	3.5
	P	30	0.8	0.8	0.8	0.8	0.8	0.8	
		35	0.8	0.8	0.8	0.9	0.9	0.9	
		45	1.0	1.0	1.0	1.1	1.1	1.1	1.1
		55		1.3	1.3	1.3	1.3	1.3	1.3
65				1.6	1.6	1.6	1.6	1.6	
ZB19KQE	Q	30	2.2	2.8	3.5	4.3	5.2	6.3	
		35	2.0	2.7	3.3	4.1	5.0	6.0	
		45	1.8	2.3	3.0	3.7	4.5	5.4	6.4
		55		2.0	2.5	3.1	3.9	4.7	5.7
		65			2.1	2.7	3.3	4.1	4.9
		75				2.2	2.7	3.4	4.0
	P	30	0.9	0.9	0.9	0.9	0.9	0.9	
		35	1.0	1.0	1.0	1.0	1.0	1.0	
		45	1.2	1.2	1.2	1.2	1.2	1.2	1.2
		55		1.5	1.5	1.5	1.5	1.5	1.5
65				1.8	1.8	1.9	1.9	1.9	
ZB21KQE	Q	30	2.8	3.5	4.4	5.4	6.5	7.9	
		35	2.7	3.3	4.2	5.1	6.2	7.5	
		45	2.3	2.9	3.7	4.6	5.6	6.8	8.1
		55		2.5	3.2	4.0	4.9	6.0	7.2
		65			2.7	3.4	4.2	5.1	6.2
		75				2.7	3.5	4.3	5.1
	P	30	1.1	1.1	1.1	1.1	1.1	1.1	
		35	1.2	1.2	1.2	1.2	1.2	1.2	
		45	1.5	1.5	1.5	1.5	1.5	1.5	1.5
		55		1.8	1.8	1.8	1.9	1.9	1.9
65				2.2	2.3	2.3	2.3	2.3	
ZB26KQE	Q	30	3.2	4.1	5.1	6.2	7.6	9.1	
		35	3.0	3.9	4.8	5.9	7.2	8.7	
		45	2.6	3.3	4.3	5.3	6.5	7.8	9.4
		55		2.9	3.7	4.6	5.7	6.9	8.3
		65			3.1	3.9	4.9	5.9	7.1
		75				3.2	4.0	5.0	5.9
	P	30	1.2	1.2	1.2	1.2	1.2	1.3	
		35	1.3	1.3	1.4	1.4	1.4	1.4	
		45	1.7	1.7	1.7	1.7	1.7	1.7	1.7
		55		2.1	2.1	2.1	2.1	2.1	2.1
65				2.6	2.6	2.6	2.6	2.6	
ZB29KQE	Q	30	3.9	4.8	5.9	7.2	8.8	10.5	
		35	3.5	4.5	5.6	6.9	8.3	10.1	
		45	3.1	3.9	5.0	6.1	7.5	9.0	10.1
		55		3.3	4.2	5.3	6.6	8.0	9.0
		65			4.0	4.5	5.6	6.8	7.7
		75				3.6	4.6	5.6	6.3
	P	30	1.4	1.4	1.4	1.4	1.4	1.4	
		35	1.5	1.6	1.6	1.6	1.6	1.6	
		45	1.9	1.9	2.0	2.0	2.0	2.0	2.0
		55		2.4	2.4	2.4	2.4	2.5	2.5
65				3.0	3.0	3.0	3.0	3.1	
75				3.8	3.8	3.8	3.8		

*20°C Return gas temperature in non-shaded region

*11K Suction superheat in shaded region

*0K Subcooling

Performance data

Q=Capacity (kW) P=Power input (kW) 1&3-Phase

R134a

50 Hz

Model		Condensing temperature °C	Evaporating temperature (°C)						
			-15	-10	-5	0	5	10	15
ZB38KQE	Q	30	4.7	5.9	7.4	9.1	11.1	13.3	
		35	4.3	5.6	7.0	8.6	10.5	12.7	
		45	3.8	4.9	6.3	7.8	9.4	11.4	13.7
		55		4.2	5.4	6.7	8.3	10.1	12.1
		65			4.6	5.7	7.1	8.7	10.4
		75				4.6	5.8	7.2	8.9
	P	30	1.7	1.7	1.7	1.8	1.8	1.8	
		35	1.9	1.9	1.9	2.0	2.0	2.0	
		45	2.3	2.4	2.4	2.4	2.4	2.5	2.5
		55		3.0	3.0	3.0	3.0	3.0	3.1
65				3.7	3.7	3.7	3.8	3.8	
ZB45KQE	Q	30	5.7	7.1	8.9	10.9	13.3	15.9	
		35	5.2	6.8	8.5	10.4	12.7	15.2	
		45	4.5	5.8	7.5	9.3	11.4	13.7	16.3
		55		5.0	6.3	8.0	10.0	12.1	14.4
		65			5.3	6.7	8.4	10.3	12.3
		75				5.4	6.8	8.5	10.1
	P	30	2.0	2.0	2.0	2.0	2.0	2.0	
		35	2.2	2.2	2.2	2.2	2.3	2.3	
		45	2.7	2.7	2.8	2.8	2.8	2.8	2.8
		55		3.4	3.4	3.5	3.5	3.5	3.5
65				4.3	4.3	4.3	4.4	4.4	
ZB48KQE	Q	30	6.4	8.1	9.9	12.2	14.7	17.6	
		35	5.9	7.7	9.5	11.6	14.0	16.9	
		45	5.2	6.6	8.5	10.4	12.6	15.1	17.3
		55		5.7	7.2	9.0	11.1	13.4	15.3
		65			6.1	7.6	9.5	11.5	13.1
		75				6.2	7.8	9.6	10.9
	P	30	2.3	2.3	2.3	2.3	2.3	2.4	
		35	2.5	2.6	2.6	2.6	2.6	2.7	
		45	3.2	3.2	3.2	3.2	3.3	3.3	3.4
		55		4.0	4.0	4.0	4.0	4.1	4.2
65				5.0	5.0	5.0	5.1	5.1	
ZB58KQE	Q	30	7.5	9.2	11.2	13.4	15.9	18.6	
		35	6.3	8.7	10.6	12.7	15.1	17.7	
		45	5.4	6.9	9.4	11.3	13.5	15.8	18.3
		55		5.9	7.5	9.3	11.7	13.8	16.0
		65			6.2	7.8	9.7	11.6	13.5
		75				6.1	7.7	9.6	10.9
	P	30	2.7	2.7	2.8	2.8	2.9	2.9	
		35	3.0	3.0	3.1	3.1	3.2	3.2	
		45	3.7	3.8	3.8	3.9	3.9	3.9	3.8
		55		4.6	4.7	4.7	4.8	4.8	4.7
65				5.6	5.7	5.8	5.8	5.7	
ZB66KQE	Q	30	8.6	10.5	12.8	15.3	18.2	21.2	
		35	7.2	10.0	12.1	14.6	17.3	20.2	
		45	6.2	7.9	10.7	12.9	15.5	18.1	20.9
		55		6.7	8.5	10.6	13.4	15.7	18.3
		65			7.0	8.9	11.0	13.3	15.4
		75				7.0	8.8	11.0	12.5
	P	30	3.0	3.0	3.1	3.2	3.2	3.3	
		35	3.4	3.4	3.4	3.5	3.5	3.6	
		45	4.2	4.2	4.3	4.3	4.3	4.3	4.3
		55		2.4	5.2	5.3	5.3	5.3	5.2
65				6.3	6.4	6.5	6.5	6.4	
75				7.7	7.8	7.8	7.8		

*20°C Return gas temperature in non-shaded region

*11K Suction superheat in shaded region

*0K Subcooling

Performance data

Q=Capacity (kW) P=Power input (kW) 1&3-Phase

R134a

50 Hz

Model		Condensing temperature °C	Evaporating temperature (°C)						
			-15	-10	-5	0	5	10	15
ZB76KQE	Q	30	9.8	12.1	14.7	17.6	20.9	24.4	
		35	8.2	11.4	13.9	16.7	19.8	23.2	
		45	7.1	9.0	12.3	14.8	17.7	20.7	24.0
		55		7.7	9.7	12.2	15.3	18.0	20.9
		65			8.1	10.1	12.6	15.2	17.7
		75				8.0	10.1	12.5	14.3
	P	30	3.5	3.6	3.6	3.7	3.8	3.8	
		35	3.9	4.0	4.0	4.1	4.2	4.2	
		45	4.9	4.9	5.0	5.0	5.1	5.1	5.0
		55		6.0	6.1	6.2	6.2	6.2	6.1
		65			7.4	7.5	7.5	7.5	7.4
		75				9.0	9.1	9.1	9.0

*20°C Return gas temperature in non-shaded region

*11K Suction superheat in shaded region

*0K Subcooling

Performance data

Q=Capacity (kW) P=Power input (kW) 1-Phase

R22
60 Hz

Model		Condensing temperature °C	Evaporating temperature (°C)						
			-12	-10	-5	0	5	10	12.5
ZB15KQ	Q	15	5.8	6.3	7.5	8.9			
		20	5.5	5.9	7.1	8.4	9.9		
		30	4.3	4.7	5.7	6.8	8.1	9.6	10.4
		40	3.9	4.3	5.2	6.2	7.4	8.8	9.6
		50	3.2	3.5	4.6	5.6	6.7	8.0	8.7
		55		3.2	3.9	4.9	5.8	6.8	7.4
		60			3.4	4.2	5.1	6.1	6.6
	65				3.6	4.5	5.3	5.7	
	P	15	1.1	1.1	1.1	1.1			
		20	1.2	1.2	1.2	1.2	1.2		
		30	1.4	1.4	1.4	1.4	1.4	1.4	1.4
		40	1.7	1.7	1.7	1.7	1.7	1.7	1.7
		50	2.1	2.0	2.0	2.0	2.0	2.0	2.0
		55		2.6	2.6	2.6	2.6	2.6	2.6
60				2.9	2.9	2.9	2.9	2.9	
65				3.2	3.2	3.2	3.2		
ZB19KQ	Q	15	5.6	6.1	7.3	8.7			
		20	5.4	5.8	7.1	8.4	10.0		
		30	5.0	5.4	6.5	7.8	9.3	11.0	12.0
		40	4.5	4.9	6.0	7.1	8.5	10.1	11.0
		50	3.7	4.1	5.3	6.4	7.7	9.2	10.0
		55		3.8	4.7	6.0	7.2	8.6	9.4
		60			4.4	5.4	6.8	8.1	8.9
	65				5.0	6.3	7.5	8.3	
	P	15	1.3	1.3	1.3	1.3			
		20	1.4	1.4	1.4	1.4	1.4		
		30	1.7	1.7	1.7	1.7	1.7	1.7	1.7
		40	2.0	2.0	2.0	2.0	2.0	2.0	2.0
		50	2.5	2.5	2.5	2.5	2.5	2.5	2.4
		55		2.8	2.7	2.7	2.7	2.7	2.7
60				3.1	3.0	3.0	3.0	3.0	
65				3.4	3.4	3.3	3.3		
ZB21KQ	Q	15	7.1	7.6	9.2	11.0			
		20	6.8	7.4	8.9	10.6	12.6		
		30	6.2	6.8	8.2	9.8	11.7	13.9	15.1
		40	5.7	6.2	7.5	9.0	10.7	12.8	13.9
		50	4.6	5.1	6.7	8.1	9.7	11.5	12.6
		55		4.8	6.0	7.6	9.1	10.9	11.9
		60			5.5	6.8	8.5	10.2	11.2
	65				6.3	7.9	9.5	10.4	
	P	15	1.6	1.6	1.6	1.6			
		20	1.8	1.7	1.8	1.8	1.8		
		30	2.1	2.1	2.1	2.1	2.1	2.2	2.2
		40	2.6	2.6	2.6	2.6	2.6	2.6	2.6
		50	3.2	3.2	3.1	3.1	3.1	3.1	3.1
		55		3.5	3.5	3.5	3.5	3.5	3.4
60				3.9	3.9	3.9	3.8	3.8	
65				4.3	4.3	4.3	4.2		

*20°C Return gas temperature in non-shaded region

*11K Suction superheat in shaded region

*0K Subcooling

Performance data

Q=Capacity (kW) P=Power input (kW) 1-Phase

R22
60 Hz

Model		Condensing temperature °C	Evaporating temperature (°C)						
			-12	-10	-5	0	5	10	12.5
ZB26KQ	Q	15	8.1	8.8	10.6	12.7			
		20	7.8	8.5	10.3	12.3	14.6		
		30	7.2	7.8	9.5	11.4	13.5	16.0	17.5
		40	6.5	7.1	8.7	10.4	12.4	14.7	16.1
		50	5.4	5.9	7.8	9.4	11.2	13.3	14.5
		55		5.5	6.9	8.8	10.5	12.6	13.7
		60			6.4	7.9	9.8	11.8	12.9
	65				7.3	9.1	11.0	12.0	
	P	15	1.8	1.8	1.8	1.9			
		20	2.0	2.0	2.0	2.0	2.1		
		30	2.4	2.4	2.4	2.4	2.5	2.5	2.5
		40	2.9	2.9	2.9	2.9	2.9	2.9	2.9
		50	3.6	3.6	3.6	3.6	3.6	3.6	3.5
		55		4.0	4.0	4.0	4.0	3.9	3.9
60				4.4	4.4	4.4	4.4	4.4	
65				4.9	4.9	4.9	4.8		
ZB29KQ	Q	15	9.5	10.3	12.4	14.6			
		20	9.2	10.0	12.1	14.3	16.7		
		30	8.5	9.3	11.3	13.4	15.8	18.6	20.2
		40	7.7	8.4	10.3	12.3	14.6	17.3	18.9
		50	6.5	7.1	9.3	11.1	13.2	15.7	17.2
		55		6.8	8.3	10.4	12.4	14.8	16.3
		60			7.9	9.5	11.6	13.9	15.3
	65				8.9	10.9	13.0	14.3	
	P	15	2.1	2.1	2.2	2.3			
		20	2.3	2.3	2.4	2.4	2.5		
		30	2.7	2.7	2.8	2.8	2.9	2.9	2.9
		40	3.2	3.2	3.3	3.3	3.4	3.4	3.4
		50	3.9	3.9	3.9	4.0	4.0	4.1	4.1
		55		4.3	4.3	4.4	4.4	4.5	4.5
60				4.7	4.8	4.9	4.9	4.9	
65				5.3	5.4	5.4	5.4		
ZB38KQ	Q	15	12.0	12.7	15.2	18.1			
		20	11.4	12.1	14.5	17.4	20.4		
		30	10.4	11.0	13.2	16.1	19.1	21.9	23.0
		40	9.5	10.0	12.0	14.8	17.8	20.6	21.8
		50	7.7	8.2	10.6	13.2	16.1	19.0	20.2
		55		7.5	9.2	12.3	15.1	18.0	19.2
		60			8.3	10.8	14.0	16.8	18.0
	65				9.6	12.7	15.4	16.7	
	P	15	2.5	2.5	2.7	2.8			
		20	2.7	2.8	2.9	3.0	3.1		
		30	3.3	3.3	3.4	3.5	3.5	3.6	3.5
		40	4.0	4.0	4.0	4.1	4.2	4.2	4.2
		50	4.8	4.8	4.9	5.0	5.0	5.1	5.1
		55		5.3	5.4	5.5	5.5	5.6	5.6
60				5.9	6.0	6.1	6.2	6.2	
65				6.6	6.7	6.8	6.8		

*20°C Return gas temperature in non-shaded region

*11K Suction superheat in shaded region

*0K Subcooling

Performance data

Q=Capacity (kW) P=Power input (kW) 3-Phase

R22
60 Hz

Model		Condensing temperature °C	Evaporating temperature (°C)						
			-12	-10	-5	0	5	10	12.5
ZB15KQ	Q	15	5.0	5.4	6.4	7.6			
		20	4.8	5.2	6.2	7.4	8.8		
		30	4.3	4.7	5.7	6.8	8.0	9.5	10.2
		40	3.9	4.2	5.1	6.2	7.4	8.7	9.5
		50	3.2	3.5	4.6	5.5	6.6	7.8	8.5
		55		3.4	4.2	5.4	6.4	7.6	8.3
		60			3.9	4.9	6.0	7.1	7.8
						4.5	5.6	6.7	7.2
	P	15	0.9	0.9	1.0	1.1			
		20	1.0	1.1	1.1	1.1	1.2		
		30	1.3	1.3	1.3	1.4	1.4	1.4	1.4
		40	1.6	1.6	1.6	1.7	1.7	1.7	1.7
		50	2.0	2.0	2.0	2.1	2.1	2.1	2.1
		55		2.2	2.2	2.2	2.2	2.3	2.3
60				2.4	2.5	2.5	2.5	2.5	
					2.7	2.7	2.8	2.8	
ZB19KQ	Q	15	5.6	6.1	7.3	8.7			
		20	5.4	5.8	7.0	8.4	10.0		
		30	4.9	5.4	6.5	7.8	9.3	11.0	11.9
		40	4.5	4.9	5.9	7.1	8.5	10.1	11.0
		50	3.7	4.0	5.3	6.4	7.7	9.1	9.9
		55		3.7	4.7	6.0	7.2	8.6	9.4
		60			4.3	5.4	6.7	8.0	8.8
						4.9	6.2	7.4	8.1
	P	15	1.2	1.2	1.2	1.2			
		20	1.3	1.3	1.3	1.4	1.4		
		30	1.6	1.6	1.7	1.7	1.7	1.7	1.7
		40	2.0	2.0	2.0	2.0	2.0	2.1	2.1
		50	2.5	2.5	2.5	2.5	2.5	2.5	2.5
		55		2.8	2.8	2.8	2.8	2.7	2.7
60				3.2	3.1	3.1	3.0	3.0	
					3.5	3.5	3.4	3.4	
ZB21KQ	Q	15	7.2	7.8	9.3	11.1			
		20	6.9	7.5	9.1	10.8	12.7		
		30	6.4	6.9	8.4	10.1	11.9	14.0	15.1
		40	5.8	6.3	7.7	9.2	11.0	12.9	14.0
		50	4.8	5.2	6.9	8.3	9.9	11.7	12.7
		55		4.9	6.1	7.8	9.3	11.0	12.0
		60			5.7	7.0	8.7	10.4	11.3
						6.5	8.1	9.7	10.5
	P	15	1.4	1.4	1.4	1.5			
		20	1.5	1.5	1.6	1.6	1.7		
		30	1.9	1.9	1.9	2.0	2.0	2.1	2.2
		40	2.3	2.3	2.3	2.4	2.4	2.5	2.5
		50	2.8	2.8	2.9	2.9	2.9	3.0	3.0
		55		3.1	3.2	3.2	3.3	3.3	3.3
60				3.5	3.6	3.6	3.6	3.6	
					3.9	4.0	4.0	4.0	

*20°C Return gas temperature in non-shaded region

*11K Suction superheat in shaded region

*0K Subcooling

Performance data

Q=Capacity (kW) P=Power input (kW) 3-Phase

R22
60 Hz

Model		Condensing temperature °C	Evaporating temperature (°C)						
			-12	-10	-5	0	5	10	12.5
ZB26KQ	Q	15	8.4	9.1	11.0	13.1			
		20	8.1	8.7	10.5	12.6	15.0		
		30	7.4	8.0	9.7	11.6	13.8	16.3	17.7
		40	6.7	7.3	8.9	10.6	12.7	15.0	16.2
		50	5.5	6.0	8.0	9.6	11.4	13.5	14.7
		55		5.6	7.1	9.0	10.8	12.7	13.9
		60			6.5	8.1	10.1	11.9	13.0
	P	65				7.5	9.3	11.1	12.1
		15	1.5	1.5	1.5	1.6			
		20	1.7	1.7	1.7	1.8	1.8		
		30	2.1	2.1	2.1	2.2	2.3	2.3	2.3
		40	2.7	2.7	2.7	2.7	2.8	2.8	2.8
		50	3.4	3.4	3.4	3.4	3.5	3.5	3.4
		55		3.8	3.8	3.8	3.9	3.9	3.8
ZB29KQ	Q	60			4.3	4.3	4.3	4.3	4.3
		65				4.8	4.8	4.8	4.8
		15	9.9	10.7	12.8	15.2			
		20	9.5	10.3	12.4	14.8	17.4		
		30	8.7	9.5	11.5	13.7	16.3	19.2	20.8
		40	7.8	8.5	10.4	12.5	14.9	17.6	19.2
		50	6.4	7.0	9.2	11.1	13.3	15.8	17.3
	P	55		6.6	8.2	10.4	12.5	14.9	16.2
		60			7.6	9.3	11.6	13.9	15.2
		65				8.6	10.7	12.8	14.0
		15	1.8	1.8	1.8	1.9			
		20	2.0	2.0	2.0	2.1	2.2		
		30	2.5	2.5	2.5	2.5	2.6	2.7	2.7
		40	3.1	3.1	3.1	3.1	3.2	3.2	3.2
ZB38KQ	Q	50	3.8	3.8	3.8	3.9	3.9	4.0	4.0
		55		4.2	4.3	4.3	4.4	4.4	4.4
		60			4.8	4.8	4.9	4.9	4.9
		65				5.4	5.4	5.5	5.4
		15	12.0	12.9	15.5	18.5			
		20	11.6	12.5	15.1	18.0	21.2		
		30	10.7	11.6	14.0	16.8	19.9	23.3	25.2
	P	40	9.7	10.5	12.8	15.4	18.3	21.5	23.3
		50	7.9	8.7	11.5	13.8	16.5	19.5	21.1
		55		8.2	10.2	13.0	15.5	18.4	20.0
		60			9.5	11.7	14.6	17.3	18.8
		65				10.9	13.6	16.1	17.5
		15	2.3	2.3	2.4	2.5			
		20	2.5	2.6	2.6	2.8	2.9		
P	30	3.1	3.2	3.2	3.3	3.4	3.5	3.6	
	40	3.9	3.9	3.9	4.0	4.1	4.2	4.2	
	50	4.7	4.8	4.8	4.9	4.9	5.0	5.0	
	55		5.3	5.3	5.4	5.5	5.5	5.5	
	60			5.9	6.0	6.0	6.1	6.1	
	65				6.6	6.7	6.7	6.7	

*20°C Return gas temperature in non-shaded region

*11K Suction superheat in shaded region

*0K Subcooling

Performance data

Q=Capacity (kW) P=Power input (kW) 3-Phase

R22
60 Hz

Model		Condensing temperature °C	Evaporating temperature (°C)						
			-12	-10	-5	0	5	10	12.5
ZB45KQ	Q	15	14.5	15.6	18.7	22.2			
		20	13.9	15.0	18.1	21.5	25.4		
		30	12.8	13.9	16.7	20.0	23.8	27.9	30.1
		40	11.6	12.6	15.3	18.4	21.9	25.7	27.8
		50	9.5	10.3	13.6	16.5	19.7	23.3	25.3
		55		9.6	12.0	15.4	18.5	22.0	23.8
		60			11.1	13.8	17.3	20.6	22.3
	65				12.7	15.9	19.1	20.8	
	P	15	2.6	2.6	2.7	2.8			
		20	2.9	2.9	3.0	3.1	3.3		
		30	3.6	3.6	3.7	3.8	3.9	4.0	4.1
		40	4.5	4.5	4.5	4.6	4.7	4.8	4.8
		50	5.5	5.5	5.6	5.6	5.7	5.8	5.8
		55		6.1	6.2	6.3	6.3	6.4	6.4
60				6.8	6.9	7.0	7.1	7.1	
65				7.7	7.8	7.8	7.8		
ZB48KQ	Q	15	15.9	17.1	20.5	24.4			
		20	15.3	16.5	19.9	23.7	28.0		
		30	14.1	15.3	18.4	22.0	26.1	30.7	33.1
		40	12.8	13.8	16.8	20.2	24.0	28.3	30.6
		50	10.4	11.4	15.0	18.1	21.6	25.6	27.8
		55		10.5	13.2	17.0	20.3	24.2	26.2
		60			12.2	15.2	19.0	22.6	24.6
	65				13.9	17.5	21.0	22.8	
	P	15	2.8	2.8	2.9	3.1			
		20	3.2	3.2	3.3	3.4	3.6		
		30	4.0	4.0	4.0	4.1	4.3	4.4	4.5
		40	4.9	4.9	5.0	5.1	5.1	5.2	5.3
		50	6.0	6.0	6.1	6.2	6.3	6.3	6.4
		55		6.7	6.8	6.9	7.0	7.0	7.0
60				7.5	7.6	7.7	7.8	7.8	
65				8.5	8.6	8.6	8.6		
ZB58KQ	Q	15	18.6	20.1	24.2	28.8			
		20	17.9	19.3	23.3	27.9	33.2		
		30	16.3	17.7	21.6	26.0	31.0	36.6	
		40	14.7	16.0	19.6	23.8	28.5	33.8	36.7
		50	11.7	12.9	17.4	21.3	25.6	30.6	33.3
		55		11.8	15.2	19.8	24.0	28.8	31.4
		60			13.9	17.7	22.3	26.9	29.4
	65				16.0	20.5	24.8	27.2	
	P	15	3.5	3.6	3.7	3.9			
		20	3.9	4.0	4.1	4.2	4.4		
		30	4.9	4.9	5.0	5.1	5.2	5.4	5.5
		40	6.0	6.0	6.1	6.1	6.2	6.3	6.3
		50	7.4	7.4	7.4	7.5	7.5	7.5	7.6
		55		8.2	8.3	8.3	8.3	8.3	8.3
60				9.2	9.2	9.2	9.2	9.2	
65				10.2	10.2	10.2	10.2		

*20°C Return gas temperature in non-shaded region

*11K Suction superheat in shaded region

*0K Subcooling

Performance data

Q=Capacity (kW) P=Power input (kW) 3-Phase

R22
60 Hz

Model		Condensing temperature °C	Evaporating temperature (°C)						
			-12	-10	-5	0	5	10	12.5
ZB66KQ	Q	15	20.5	22.2	26.9	32.3			
		20	19.8	21.5	26.0	31.3	37.4		
		30	18.4	20.0	24.2	29.2	34.8	41.2	44.7
		40	16.9	18.3	22.3	26.8	32.0	37.9	41.1
		50	13.8	15.2	20.1	24.2	29.0	34.3	37.3
		55		14.2	17.8	22.9	27.3	32.4	35.2
		60			16.6	20.6	25.7	30.5	33.1
	65				19.1	23.9	28.4	30.9	
	P	15	3.9	3.9	4.1	4.3			
		20	4.4	4.4	4.5	4.7	4.9		
		30	5.4	5.4	5.5	5.7	5.8	6.0	6.1
		40	6.6	6.6	6.7	6.8	7.0	7.1	7.2
		50	8.1	8.1	8.2	8.3	8.4	8.5	8.6
		55		9.0	9.1	9.2	9.3	9.3	9.4
60				10.1	10.2	10.2	10.3	10.3	
65				11.2	11.3	11.4	11.4		
ZB76KQ	Q	15	24.5	26.6	32.2	38.7			
		20	23.8	25.7	31.2	37.4	44.4		
		30	22.2	24.0	29.0	34.7	41.1	48.4	52.3
		40	20.3	21.9	26.6	31.8	37.7	44.3	47.9
		50	16.5	18.1	23.9	28.7	34.1	40.2	43.4
		55		16.8	21.1	27.0	32.2	38.0	41.1
		60			19.5	24.3	30.2	35.7	38.7
	65				22.5	28.1	33.4	36.2	
	P	15	4.8	4.9	5.0	5.3			
		20	5.3	5.3	5.5	5.6	5.9		
		30	6.4	6.4	6.5	6.7	6.9	7.1	7.2
		40	7.8	7.9	8.0	8.1	8.2	8.4	8.5
		50	9.7	9.7	9.8	9.9	10.0	10.1	10.2
		55		10.8	10.9	10.9	11.0	11.1	11.2
60				12.1	12.1	12.2	12.3	12.4	
65				13.4	13.5	13.6	13.6		
ZB88KQ	Q	15	33.4	36.3	43.7	51.2			
		20	30.2	32.9	40.1	47.4	54.7		
		30	25.4	27.8	34.4	41.4	48.5	55.3	58.5
		40	22.2	24.2	30.1	36.6	43.4	50.3	53.5
		50	18.0	19.7	26.4	32.3	38.8	45.5	48.8
		55		18.4	23.1	30.1	36.4	43.0	46.3
		60			21.2	26.8	33.9	40.3	43.6
	65				24.2	31.0	37.3	40.6	
	P	15	5.4	5.5	5.7	6.0			
		20	5.9	6.0	6.2	6.5	6.8		
		30	7.2	7.3	7.4	7.6	7.9	8.2	8.4
		40	8.8	8.9	9.0	9.1	9.3	9.6	9.7
		50	10.8	10.8	11.0	11.1	11.2	11.4	11.5
		55		12.0	12.2	12.3	12.4	12.5	12.6
60				13.5	13.6	13.7	13.8	13.9	
65				15.1	15.2	15.3	15.3		

*20°C Return gas temperature in non-shaded region

*11K Suction superheat in shaded region

*0K Subcooling

Performance data

Q=Capacity (kW) P=Power input (kW) 3-Phase

R22
60 Hz

Model		Condensing temperature °C	Evaporating temperature (°C)						
			-12	-10	-5	0	5	10	12.5
ZB95KQ	Q	15	30.7	33.2	40.0	47.9			
		20	29.6	32.0	38.7	46.3	54.9		
		30	27.0	29.3	35.7	42.8	50.8	59.8	64.6
		40	23.9	26.1	32.1	38.9	46.4	54.7	59.2
		50			28.1	34.4	41.5	49.3	53.4
		55				32.0	38.8	46.3	50.3
		60					36.0	43.3	47.1
		65					33.0	40.0	43.8
	P	15	5.9	6.1	6.4	6.8			
		20	6.5	6.6	6.9	7.2	7.7		
		30	8.0	8.1	8.2	8.5	8.8	9.2	9.4
		40	10.0	10.0	10.2	10.3	10.5	10.7	10.9
		50			12.6	12.7	12.9	13.0	13.1
		55				14.1	14.3	14.4	14.5
60						15.8	16.0	16.0	
	65					17.5	17.6	17.7	
ZB114KQ	Q	15	36.6	39.8	49.1	60.3			
		20	35.1	38.1	46.6	56.9	69.2		
		30	32.2	34.9	42.4	51.1	61.5	73.8	80.7
		40	28.8	31.5	38.4	46.2	55.2	65.6	71.5
		50			33.9	41.3	49.4	58.5	63.5
		55				38.5	46.4	55.1	59.8
		60					43.2	51.6	56.0
		65					39.7	47.9	52.2
	P	15	7.3	7.4	7.7	8.2			
		20	8.0	8.1	8.4	8.8	9.4		
		30	9.7	9.8	10.0	10.3	10.7	11.3	11.6
		40	11.9	11.9	12.1	12.3	12.6	13.0	13.2
		50			14.8	14.9	15.1	15.4	15.6
		55				16.5	16.7	16.9	17.0
60						18.4	18.6	18.7	
	65					20.4	20.5	20.6	

*20°C Return gas temperature in non-shaded region

*11K Suction superheat in shaded region

*0K Subcooling

Performance data

Q=Capacity (kW) P=Power input (kW) 3-Phase

R22
60 Hz

Model		Condensing temperature °C	Evaporating temperature (°C)						
			-12	-10	-5	0	5	10	12
ZB130KQ	Q	15	40.5	43.7	52.7	63.1			
		20	38.6	41.8	50.5	60.6	72.1		
		25	36.8	39.9	48.5	58.2	69.3		
		30	35.1	38.1	46.5	55.9	66.6	78.7	83.9
		35	33.3	36.3	44.5	53.7	64.0	75.5	80.5
		40	31.3	34.3	42.3	51.3	61.2	72.3	77.0
		45	28.4	31.5	40.0	48.7	58.3	68.9	73.4
		50	25.7	28.8	37.4	45.8	55.1	65.3	69.6
		55	22.6	25.7	33.7	42.7	51.6	61.3	65.5
	60			30.1	38.5	47.7	57.0	61.0	
	65				34.2	43.3	52.2	56.0	
	P	15	6.9	7.0	7.1	7.3			
		20	7.9	7.9	8.1	8.3	8.6		
		25	8.9	8.9	9.1	9.3	9.6		
		30	9.9	10.0	10.1	10.3	10.6	10.8	11.0
		35	11.0	11.0	11.2	11.4	11.7	11.9	12.0
		40	12.2	12.2	12.4	12.60	12.8	13.1	13.2
		45	13.4	13.5	13.7	13.9	14.1	14.3	14.4
50		14.9	15.0	15.1	15.4	15.6	15.8	15.9	
55		16.5	16.5	16.8	17.0	17.2	17.4	17.5	
60			18.6	18.8	19.0	19.2	19.2		
65				20.8	21.0	21.2	21.3		
ZB150KQ	Q	15	47.8	51.4	61.7	74.2			
		20	45.9	49.5	59.4	71.4	85.6		
		25	44.1	47.5	57.2	68.7	82.3		
		30	42.3	45.6	55.0	66.0	79.0	94.4	101.3
		35	40.4	43.7	52.8	63.4	75.8	90.5	97.0
		40	38.4	41.6	50.5	60.7	72.6	86.6	92.8
		45	36.0	39.2	48.1	57.9	69.3	82.6	88.5
		50	33.5	36.7	45.5	55.0	65.9	78.6	84.2
		55	30.7	33.9	42.4	51.9	62.4	74.4	79.8
	60			39.2	48.3	58.7	70.1	75.2	
	65				44.6	54.7	65.6	70.4	
	P	15	8.2	8.4	8.8	9.2			
		20	9.8	10.0	10.4	10.8	11.0		
		25	11.3	11.5	11.8	12.2	12.5		
		30	12.8	12.9	13.2	13.6	13.9	14.1	14.1
		35	14.3	14.3	14.6	14.9	15.3	15.5	15.6
		40	15.9	15.9	16.0	16.3	16.7	17.0	17.1
		45	17.6	17.5	17.6	17.8	18.2	18.5	18.7
50		19.6	19.4	19.4	19.6	19.9	20.2	20.4	
55		21.8	21.6	21.4	21.5	21.8	22.2	22.3	
60			23.8	23.8	24.0	24.4	24.5		
65				26.5	26.6	26.9	27.1		

*20°C Return gas temperature in non-shaded region

*11K Suction superheat in shaded region

*0K Subcooling

Performance data

Q=Capacity (kW) P=Power input (kW) 3-Phase

R22
60 Hz

Model		Condensing temperature °C	Evaporating temperature (°C)						
			-12	-10	-5	0	5	10	12
ZB190KQ	Q	15	59.0	63.4	76.3	92.0			
		20	55.5	59.8	72.3	87.4	105.0		
		25	52.7	57.0	69.2	83.8	100.6		
		30	50.4	54.6	66.6	80.8	97.0	115.2	123.1
		35	48.2	52.4	64.3	78.1	93.8	111.2	118.7
		40	45.7	50.0	61.8	75.4	90.6	107.4	114.5
		45	41.2	45.7	58.9	72.3	87.1	103.3	110.2
		50	36.8	41.5	55.1	68.5	83.0	98.7	105.3
		55	31.0	35.9	48.9	63.6	78.0	93.3	99.7
	60			42.1	56.3	71.6	86.6	92.8	
	65				48.0	63.6	78.4	84.4	
	P	15	12.2	12.5	13.4	14.7			
		20	13.0	13.2	13.9	14.9	16.1		
		25	14.2	14.3	14.8	15.5	16.5		
		30	15.6	15.7	16.0	16.6	17.4	18.4	18.9
		35	17.4	17.5	17.6	18.0	18.6	19.5	19.9
		40	19.5	19.5	19.5	19.8	20.3	21.0	21.3
		45	21.7	21.7	21.7	21.9	22.3	22.8	23.1
50		24.1	24.1	24.1	24.3	24.6	25.1	25.3	
55		26.7	26.7	26.8	26.9	27.2	27.6	27.9	
60			29.5	29.7	30.1	30.5	30.7		
65				32.7	33.1	33.6	33.8		
ZB220KQ	Q	15	73.8	79.4	94.7	112.6			
		20	71.0	76.4	91.2	108.4	128.8		
		25	68.1	73.5	87.9	104.4	123.9		
		30	65.2	70.5	84.6	100.6	119.2	141.2	151.2
		35	62.1	67.4	81.2	96.7	114.5	135.6	145.1
		40	58.6	63.9	77.7	92.7	109.9	130.0	139.0
		45	53.3	58.9	73.9	88.6	105.2	124.4	133.0
		50	48.6	54.3	69.6	84.2	100.2	118.7	126.9
		55	43.2	49.1	63.5	79.3	95.0	112.7	120.6
	60			57.9	72.8	89.3	106.4	114.0	
	65				66.6	83.0	99.7	107.0	
	P	15	12.6	12.8	13.4	13.7			
		20	14.8	15.0	15.7	16.2	16.0		
		25	16.9	17.1	17.8	18.5	18.6		
		30	19.1	19.2	19.8	20.6	21.0	20.3	19.7
		35	21.3	21.3	21.8	22.6	23.2	22.9	22.5
		40	23.8	23.7	24.0	24.7	25.4	25.4	25.1
		45	26.7	26.4	26.4	27.0	27.7	27.9	27.8
50		30.1	29.6	29.1	29.6	30.2	30.6	30.5	
55		34.0	33.3	32.4	32.5	33.0	33.4	33.4	
60			36.2	36.0	36.3	36.6	36.7		
65				40.1	40.1	40.3	40.3		

*20°C Return gas temperature in non-shaded region

*11K Suction superheat in shaded region

*0K Subcooling

Performance data

Q=Capacity (kW) P=Power input (kW) 1-Phase

R404A

60 Hz

Model		Condensing temperature °C	Evaporating temperature (°C)						
			-20	-15	-10	-5	0	5	10
ZB15KQE	Q	10	4.4	5.4	6.6				
		20	4.0	4.9	5.9	7.1	8.4		
		30	3.6	4.4	5.3	6.3	7.5	8.8	10.3
		40	3.1	3.8	4.6	5.5	6.5	7.6	8.9
		50	2.6	3.2	3.8	4.6	5.4	6.4	7.5
		60		2.5	3.8	3.6	4.3	5.1	6.1
	P	10	0.9	1.0	1.0				
		20	1.2	1.2	1.2	1.2	1.2		
		30	1.5	1.5	1.5	1.5	1.5	1.5	1.5
		40	1.8	1.9	1.9	1.9	1.9	1.9	1.8
ZB19KQE	Q	10	5.5	6.8	8.2				
		20	5.0	6.1	7.4	8.9	10.5		
		30	4.5	5.4	6.6	7.9	9.3	11.0	12.8
		40	3.9	4.7	5.7	6.8	8.1	9.5	11.2
		50	3.2	3.9	4.8	5.7	6.8	8.0	9.4
		60		3.1	3.7	4.5	5.4	6.4	7.6
	P	10	1.2	1.2	1.2				
		20	1.5	1.5	1.5	1.5	1.5		
		30	1.8	1.9	1.9	1.9	1.9	1.9	1.8
		40	2.3	2.3	2.3	2.3	2.3	2.3	2.3
ZB21KQE	Q	10	6.6	8.1	9.8				
		20	6.0	7.3	8.8	10.6	12.6		
		30	5.3	6.5	7.8	9.4	11.1	13.1	15.4
		40	4.6	5.6	6.8	8.1	9.7	11.2	13.3
		50	3.8	4.7	5.7	6.8	8.1	9.6	11.2
		60		3.7	4.5	5.4	6.4	7.7	9.0
	P	10	1.4	1.4	1.4				
		20	1.8	1.8	1.8	1.8	1.8		
		30	2.2	2.2	2.2	2.2	2.2	2.2	2.2
		40	2.8	2.8	2.8	2.8	2.8	2.9	2.8
ZB26KQE	Q	10	7.7	9.4	11.4				
		20	7.0	8.5	10.3	12.4	14.7		
		30	6.2	7.6	9.2	11.0	13.0	15.3	17.9
		40	5.4	6.6	7.9	9.5	11.3	13.3	15.6
		50	4.5	5.5	6.6	8.0	9.5	11.2	13.1
		60		4.3	5.2	6.3	7.5	8.9	10.5
	P	10	1.6	1.7	1.7				
		20	2.1	2.1	2.1	2.1	2.1		
		30	2.6	2.6	2.6	2.6	2.6	2.6	2.6
		40	3.2	3.2	3.3	3.3	3.3	3.2	3.2
	50	4.0	4.1	4.1	4.1	4.1	4.1	4.0	
	60		5.1	5.1	5.1	5.1	5.0	5.0	

*20°C Return gas temperature in non-shaded region

*11K Suction superheat in shaded region

*0K Subcooling

Performance data

Q=Capacity (kW) P=Power input (kW) 1-Phase

R404A

60 Hz

Model		Condensing temperature °C	Evaporating temperature (°C)						
			-20	-15	-10	-5	0	5	10
ZB29KQE	Q	10	8.6	10.6	12.8				
		20	7.8	9.6	11.6	14.0	16.7		
		30	6.9	8.5	10.4	12.5	14.8	17.5	20.5
		40	5.9	7.4	9.0	10.8	12.9	15.2	17.8
		50	4.8	6.1	7.4	9.0	10.7	12.7	14.9
		60		4.6	5.8	7.0	8.5	10.1	11.9
	P	10	2.1	2.1	2.2				
		20	2.5	2.5	2.5	2.6	2.6		
		30	3.0	3.0	3.0	3.1	3.1	3.2	3.2
		40	3.6	3.6	3.7	3.7	3.7	3.8	3.8
		50	4.4	4.4	4.4	4.5	4.5	4.5	4.6
ZB38KQE	Q	10	10.9	13.2	15.8				
		20	9.9	12.1	14.6	17.4	20.5		
		30	8.7	10.8	13.1	15.7	18.5	21.7	25.1
		40	7.4	9.2	11.3	13.6	16.2	19.0	22.2
		50	6.0	7.5	9.3	11.2	13.5	16.0	18.8
		60		5.8	7.2	8.8	10.6	12.6	15.0
	P	10	2.6	2.6	2.8				
		20	3.0	3.1	3.2	3.3	3.4		
		30	3.7	3.7	3.8	3.8	4.0	4.1	4.3
		40	4.5	4.5	4.6	4.6	4.7	4.8	4.9
		50	5.4	5.5	5.6	5.6	5.7	5.7	5.8
	60		6.7	6.7	6.8	6.9	6.9	7.0	

*20°C Return gas temperature in non-shaded region

*11K Suction superheat in shaded region

*0K Subcooling

Performance data

Q=Capacity (kW) P=Power input (kW) 3-Phase

R404A

60 Hz

Model		Condensing temperature °C	Evaporating temperature (°C)						
			-20	-15	-10	-5	0	5	10
ZB15KQE	Q	10	4.4	5.4	6.6				
		20	4.0	4.9	5.9	7.1	8.6		
		30	3.5	4.3	5.3	6.3	7.6	9.0	10.6
		40	3.0	3.7	4.5	5.4	6.5	7.7	9.1
		50	2.4	3.0	3.7	4.5	5.4	6.4	7.6
		60		2.2	2.8	3.5	4.2	5.0	5.9
	P	10	1.0	0.9	0.9				
		20	1.2	1.2	1.2	1.2	1.1		
		30	1.5	1.5	1.5	1.5	1.5	1.4	1.4
		40	2.0	1.9	1.9	1.9	1.9	1.9	1.8
ZB19KQE	Q	10	5.5	6.7	8.1				
		20	5.0	6.1	7.3	8.8	10.4		
		30	4.4	5.4	6.5	7.8	9.3	10.9	12.7
		40	3.8	4.7	5.7	6.8	8.0	9.5	11.1
		50	3.2	3.9	4.7	5.7	6.7	8.0	9.3
		60		3.0	3.7	4.5	5.4	6.4	7.5
	P	10	1.1	1.1	1.1				
		20	1.4	1.4	1.4	1.4	1.4		
		30	1.8	1.8	1.8	1.8	1.8	1.8	1.8
		40	2.2	2.2	2.2	2.2	2.2	2.2	2.2
50		2.8	2.8	2.8	2.8	2.8	2.8	2.8	
60			3.5	3.5	3.5	3.5	3.5	3.4	
ZB21KQE	Q	10	6.6	8.1	9.8				
		20	6.0	7.3	8.8	10.5	12.5		
		30	5.3	6.5	7.8	9.4	11.1	13.1	15.3
		40	4.6	5.6	6.8	8.1	9.6	11.4	13.3
		50	3.8	4.7	5.7	6.8	8.1	9.5	11.2
		60		3.6	4.4	5.4	6.4	7.6	9.0
	P	10	1.4	1.4	1.4				
		20	1.7	1.7	1.7	1.7	1.7		
		30	2.1	2.1	2.1	2.2	2.1	2.1	2.1
		40	2.7	2.7	2.7	2.7	2.7	2.7	2.7
50		3.3	3.3	3.3	3.4	3.3	3.3	3.3	
60			4.2	4.2	4.2	4.2	4.2	4.1	
ZB26KQE	Q	10	7.7	9.4	11.4				
		20	6.9	8.5	10.2	12.3	14.6		
		30	6.2	7.5	9.1	10.9	12.9	15.2	17.8
		40	5.4	6.5	7.9	9.4	11.2	13.2	15.5
		50	4.4	5.4	6.6	7.9	9.4	11.1	13.0
		60		4.2	5.2	6.2	7.5	8.9	10.5
	P	10	1.6	1.6	1.6				
		20	2.0	2.0	2.0	2.0	2.0		
		30	2.5	2.5	2.5	2.5	2.5	2.5	2.5
		40	3.1	3.1	3.1	3.1	3.1	3.1	3.1
50		3.9	3.9	3.9	3.9	3.9	3.9	3.9	
60			4.9	4.9	4.9	4.9	4.9	4.8	
ZB29KQE	Q	10	8.7	10.6	12.9				
		20	7.9	9.6	11.6	13.9	16.6		
		30	7.0	8.5	10.3	12.4	14.7	17.3	20.2
		40	6.1	7.4	9.0	10.7	12.7	15.0	17.6
		50	5.0	6.2	7.5	9.0	10.7	12.6	14.8
		60		4.8	5.9	7.1	8.5	10.1	11.9
	P	10	1.8	1.8	1.8				
		20	2.2	2.2	2.2	2.2	2.2		
		30	2.8	2.8	2.8	2.8	2.8	2.8	2.8
		40	3.5	3.5	3.5	3.5	3.5	3.5	3.5
	50	4.3	4.3	4.4	4.4	4.4	4.3	4.3	
	60		5.4	5.4	5.4	5.4	5.4	5.4	

*20°C Return gas temperature in non-shaded region

*11K Suction superheat in shaded region

*0K Subcooling

Performance data

Q=Capacity (kW) P=Power input (kW) 3-Phase

R404A

60 Hz

Model		Condensing temperature °C	Evaporating temperature (°C)						
			-20	-15	-10	-5	0	5	10
ZB38KQE	Q	10	11.0	13.4	16.2				
		20	9.9	12.1	14.6	17.6	20.9		
		30	8.8	10.8	13.0	15.6	18.5	21.8	25.5
		40	7.6	9.3	11.3	13.5	16.0	18.9	22.1
		50	6.3	7.8	9.4	11.3	13.4	15.9	18.6
		60		6.0	7.4	8.9	10.7	12.7	15.0
	P	10	2.2	2.2	2.3				
		20	2.8	2.8	2.8	2.8	2.8		
		30	3.5	3.5	3.5	3.5	3.5	3.5	3.5
		40	4.4	4.4	4.4	4.4	4.4	4.4	4.4
ZB45KQE	Q	10	13.0	15.9	19.3				
		20	11.8	14.4	17.4	20.8	24.8		
		30	10.5	12.8	15.4	18.5	21.9	25.9	30.3
		40	9.1	11.1	13.4	16.0	19.0	22.4	26.3
		50	7.5	9.2	11.2	13.4	16.0	18.9	22.1
		60		7.2	8.8	10.6	12.7	15.1	17.8
	P	10	2.6	2.6	2.6				
		20	3.2	3.3	3.3	3.3	3.3		
		30	4.1	4.1	4.1	4.1	4.1	4.1	4.1
		40	5.1	5.1	5.1	5.2	5.1	5.1	5.1
ZB48KQE	Q	10	14.3	17.5	21.2				
		20	12.9	15.8	19.1	22.9	27.2		
		30	11.5	14.0	17.0	20.3	24.1	28.4	33.3
		40	10.0	12.2	14.7	17.6	20.9	24.7	28.9
		50	8.3	10.1	12.3	14.7	17.5	20.7	24.3
		60		7.9	9.6	11.6	13.9	16.6	19.5
	P	10	2.9	2.9	2.9				
		20	3.6	3.6	3.6	3.6	3.6		
		30	4.5	4.5	4.5	4.5	4.5	4.5	4.5
		40	5.6	5.6	5.7	5.7	5.7	5.6	5.6
ZB58KQE	Q	10	16.5	20.1	24.4				
		20	15.1	18.4	22.2	26.7	32.0		
		30	13.6	16.6	20.0	23.9	28.5	33.9	40.1
		40	11.6	14.4	17.5	21.0	24.9	29.5	34.9
		50	9.1	11.8	14.6	17.6	21.0	25.0	29.5
		60		8.4	11.0	13.7	16.6	19.9	23.7
	P	10	3.7	3.8	3.9				
		20	4.5	4.6	4.7	4.8	4.8		
		30	5.5	5.6	5.7	5.8	5.8	5.9	5.8
		40	6.8	6.9	6.9	7.0	7.1	7.1	7.1
ZB66KQE	Q	10	19.0	23.2	28.2				
		20	17.3	21.1	25.6	30.8	36.8		
		30	15.4	18.8	22.8	27.3	32.5	38.5	45.3
		40	13.4	16.4	19.8	23.7	28.2	33.3	39.1
		50	11.2	13.7	16.6	19.9	23.6	27.8	32.6
		60		10.7	13.1	15.7	18.7	22.0	25.9
	P	10	4.1	4.3	4.4				
		20	5.0	5.2	5.3	5.5	5.7		
		30	6.1	6.3	6.4	6.6	6.7	6.8	7.0
		40	7.5	7.6	7.8	7.9	8.0	8.1	8.2
ZB66KQE	Q	10	19.0	23.2	28.2				
		20	17.3	21.1	25.6	30.8	36.8		
		30	15.4	18.8	22.8	27.3	32.5	38.5	45.3
		40	13.4	16.4	19.8	23.7	28.2	33.3	39.1
		50	11.2	13.7	16.6	19.9	23.6	27.8	32.6
		60		10.7	13.1	15.7	18.7	22.0	25.9
	P	10	4.1	4.3	4.4				
		20	5.0	5.2	5.3	5.5	5.7		
		30	6.1	6.3	6.4	6.6	6.7	6.8	7.0
		40	7.5	7.6	7.8	7.9	8.0	8.1	8.2
ZB66KQE	Q	10	19.0	23.2	28.2				
		20	17.3	21.1	25.6	30.8	36.8		
		30	15.4	18.8	22.8	27.3	32.5	38.5	45.3
		40	13.4	16.4	19.8	23.7	28.2	33.3	39.1
		50	11.2	13.7	16.6	19.9	23.6	27.8	32.6
		60		10.7	13.1	15.7	18.7	22.0	25.9
	P	10	4.1	4.3	4.4				
		20	5.0	5.2	5.3	5.5	5.7		
		30	6.1	6.3	6.4	6.6	6.7	6.8	7.0
		40	7.5	7.6	7.8	7.9	8.0	8.1	8.2
ZB66KQE	Q	10	19.0	23.2	28.2				
		20	17.3	21.1	25.6	30.8	36.8		
		30	15.4	18.8	22.8	27.3	32.5	38.5	45.3
		40	13.4	16.4	19.8	23.7	28.2	33.3	39.1
		50	11.2	13.7	16.6	19.9	23.6	27.8	32.6
		60		10.7	13.1	15.7	18.7	22.0	25.9
	P	10	4.1	4.3	4.4				
		20	5.0	5.2	5.3	5.5	5.7		
		30	6.1	6.3	6.4	6.6	6.7	6.8	7.0
		40	7.5	7.6	7.8	7.9	8.0	8.1	8.2
ZB66KQE	Q	10	19.0	23.2	28.2				
		20	17.3	21.1	25.6	30.8	36.8		
		30	15.4	18.8	22.8	27.3	32.5	38.5	45.3
		40	13.4	16.4	19.8	23.7	28.2	33.3	39.1
		50	11.2	13.7	16.6	19.9	23.6	27.8	32.6
		60		10.7	13.1	15.7	18.7	22.0	25.9
	P	10	4.1	4.3	4.4				
		20	5.0	5.2	5.3	5.5	5.7		
		30	6.1	6.3	6.4	6.6	6.7	6.8	7.0
		40	7.5	7.6	7.8	7.9	8.0	8.1	8.2
ZB66KQE	Q	10	19.0	23.2	28.2				
		20	17.3	21.1	25.6	30.8	36.8		
		30	15.4	18.8	22.8	27.3	32.5	38.5	45.3
		40	13.4	16.4	19.8	23.7	28.2	33.3	39.1
		50	11.2	13.7	16.6	19.9	23.6	27.8	32.6
		60		10.7	13.1	15.7	18.7	22.0	25.9
	P	10	4.1	4.3	4.4				
		20	5.0	5.2	5.3	5.5	5.7		
		30	6.1	6.3	6.4	6.6	6.7	6.8	7.0
		40	7.5	7.6	7.8	7.9	8.0	8.1	8.2
ZB66KQE	Q	10	19.0	23.2	28.2				
		20	17.3	21.1	25.6	30.8	36.8		
		30	15.4	18.8	22.8	27.3	32.5	38.5	45.3
		40	13.4	16.4	19.8	23.7	28.2	33.3	39.1
		50	11.2	13.7	16.6	19.9	23.6	27.8	32.6
		60		10.7	13.1	15.7	18.7	22.0	25.9
	P	10	4.1	4.3	4.4				
		20	5.0	5.2	5.3	5.5	5.7		
		30	6.1	6.3	6.4	6.6	6.7	6.8	7.0
		40	7.5	7.6	7.8	7.9	8.0	8.1	8.2
ZB66KQE	Q	10	19.0	23.2	28.2				
		20	17.3	21.1	25.6	30.8	36.8		
		30	15.4	18.8	22.8	27.3	32.5	38.5	45.3
		40	13.4	16.4	19.8	23.7	28.2	33.3	39.1
		50	11.2	13.7	16.6	19.9	23.6	27.8	32.6
		60		10.7	13.1	15.7	18.7	22.0	25.9
	P	10	4.1	4.3	4.4				
		20	5.0	5.2	5.3	5.5	5.7		
		30	6.1	6.3	6.4	6.6	6.7	6.8	7.0
		40	7.5	7.6	7.8	7.9	8.0	8.1	8.2
ZB66KQE	Q	10	19.0	23.2	28.2				
		20	17.3	21.1	25.6	30.8	36.8		
		30	15.4	18.8	22.8	27.3	32.5	38.5	45.3
		40	13.4	16.4	19.8	23.7	28.2	33.3	39.1
		50	11.2	13.7	16.6	19.9	23.6	27.8	32.6
		60		10.7	13.1	15.7	18.7	22.0	25.9
	P	10	4.1	4.3	4.4				
		20	5.0	5.2	5.3	5.5	5.7		
		30	6.1	6.3	6.4	6.6	6.7	6.8	7.0
		40	7.5	7.6	7.8	7.9	8.0	8.1	8.2
ZB66KQE	Q	10	19.0	23.2	28.2				
		20	17.3	21.1	25.6	30.8	36.8		
		30	15.4	18.8	22.8	27.3	32.5	38.5	45.3
		40	13.4	16.4	19.8	23.7	28.2	33.3	39.1
		50	11.2	13.7	16.6	19.9	23.6	27.8	32.6
		60		10.7	13.1	15.7	18.7	22.0	25.9
	P	10	4.1	4.3	4.4				
		20	5.0	5.2	5.3	5.5	5.7		
		30	6.1	6.3	6.4	6.6	6.7	6.8	7.0
		40	7.5	7.6	7.8	7.9	8.0	8.1	8.2
ZB66KQE	Q	10	19.0	23.2	28.2				
		20	17.3	21.1	25.6	30.8	36.8		
		30	15.4	18.8	22.8	27.3	32.5	38.5	45.3
		40	13.4	16.4	19.8	23.7	28.2	33.3	39.1
		50	11.2	13.7	16.6	19.9	23.6	27.8	32.6
		60		10.7	13.1	15.7	18.7	22.0	25.9
	P	10	4.1	4.3	4.4				
		20	5.0	5.2	5.3	5.5	5.7		
		30	6.1	6.3	6.4	6.6	6.7	6.8	7.0
		40	7.5	7.6	7.8	7.9	8.0	8.1	8.2
ZB66KQE	Q	10	19.0	23.2	28.2				

Performance data

Q=Capacity (kW) P=Power input (kW) 3-Phase

R404A

60 Hz

Model		Condensing temperature °C	Evaporating temperature (°C)						
			-20	-15	-10	-5	0	5	10
ZB76KQE	Q	10	22.3	27.1	32.8				
		20	20.2	24.7	29.9	35.9	42.8		
		30	18.1	22.1	26.7	32.0	38.2	45.2	53.1
		40	15.9	19.3	23.3	27.9	33.2	39.3	46.2
		50	13.6	16.5	19.8	23.6	28.0	33.0	38.9
		60		13.5	16.0	19.0	22.5	26.5	31.2
	P	10	4.8	5.0	5.2				
		20	5.9	6.0	6.1	6.3	6.5		
		30	7.2	7.3	7.5	7.6	7.7	7.8	7.9
		40	8.7	8.9	9.1	9.2	9.3	9.4	9.5
50		10.5	10.8	11.0	11.2	11.3	11.4	11.5	
60			12.8	13.2	13.5	13.7	13.8	13.9	
ZB95KQE	Q	10	27.4	33.4	40.5				
		20	25.0	30.5	36.9	44.3	52.8		
		30	22.3	27.3	33.0	39.6	47.1	55.7	65.6
		40	19.2	23.7	28.8	34.5	41.0	48.4	56.9
		50		19.5	24.0	28.9	34.4	40.6	47.7
		60			18.4	22.5	27.1	32.1	37.9
	P	10	6.2	6.4	6.8				
		20	7.5	7.7	8.0	8.3	8.6		
		30	9.2	9.4	9.6	9.8	10.1	10.4	10.6
		40	11.5	11.6	11.8	11.9	12.1	12.3	12.5
50			14.4	14.5	14.6	14.7	14.8	15.0	
60				18.0	18.0	18.1	18.1	18.2	
ZB114KQE	Q	10	32.8	40.2	48.8				
		20	29.8	36.5	44.2	53.1	63.3		
		30	26.5	32.6	39.5	47.4	56.4	66.6	78.1
		40	22.8	28.2	34.3	41.2	49.0	57.9	67.9
		50		23.2	28.5	34.5	41.2	48.7	57.2
		60			22.0	27.0	32.6	38.8	45.8
	P	10	7.5	7.7	8.0				
		20	9.1	9.3	9.6	9.9	10.1		
		30	11.1	11.3	11.6	11.8	12.0	12.3	12.4
		40	13.6	13.8	14.0	14.2	14.4	14.6	14.8
50			16.9	17.1	17.3	17.5	17.6	17.7	
60				21.0	21.1	21.2	21.3	21.3	

*20°C Return gas temperature in non-shaded region

*11K Suction superheat in shaded region

*0K Subcooling

Performance data

Q=Capacity (kW) P=Power input (kW) 3-Phase

R404A

60 Hz

Model		Condensing temperature °C	Evaporating temperature (°C)						
			-20	-15	-10	-5	0	5	10
ZB130KQE	Q	10	36.7	44.0	52.7				
		15	34.3	41.3	49.7	59.5			
		20	32.2	38.9	46.9	56.3	67.2		
		25	30.2	36.7	44.4	53.3	63.6	75.4	
		30	28.4	34.7	41.9	50.3	60.0	71.1	83.8
		35	26.6	32.6	39.5	47.4	56.5	66.8	78.6
		40	24.8	30.6	37.1	44.4	52.8	62.4	73.4
		45	22.8	28.4	34.5	41.3	49.1	57.9	68.0
		50		25.9	31.7	38.0	45.1	53.2	62.4
		55			28.6	34.4	40.9	48.2	56.4
	60			25.1	30.4	36.3	42.8	50.1	
	P	10	8.0	8.1	8.3				
		15	8.4	8.5	8.7	8.9			
		20	9.0	9.2	9.3	9.5	9.7		
		25	9.8	10.0	10.2	10.4	10.6	10.8	
		30	10.9	11.1	11.3	11.4	11.6	11.7	12.0
		35	12.1	12.3	12.5	12.7	12.8	12.9	13.1
		40	13.5	13.7	13.9	14.1	14.2	14.3	14.4
45		15.0	15.3	15.5	15.6	15.7	15.8	15.9	
50			17.0	17.2	17.3	17.4	17.5	17.5	
55				19.0	19.2	19.3	19.3	19.3	
60			21.0	21.1	21.2	21.2	21.1		
ZB150KQE	Q	10	42.6	51.3	61.4				
		15	40.9	49.6	59.6	71.0			
		20	38.9	47.4	57.3	68.4	81.1		
		25	36.7	45.0	54.5	65.4	77.7	91.6	
		30	34.6	42.5	51.5	61.9	73.7	87.1	102.1
		35	32.6	39.9	48.4	58.2	69.3	82.1	96.4
		40	30.9	37.5	45.3	54.3	64.7	76.7	90.2
		45	29.5	35.3	42.3	50.4	60.0	71.0	83.6
		50			39.5	46.7	55.2	65.2	76.8
		55				43.3	50.6	59.5	69.8
	60					46.3	53.9	62.9	
	P	10	10.7	11.4	12.6				
		15	11.2	11.5	12.2	13.4			
		20	12.2	12.3	12.5	13.2	14.7		
		25	13.5	13.5	13.5	13.8	14.7	16.5	
		30	15.0	15.1	15.0	15.0	15.4	16.7	19.0
		35	16.4	16.7	16.7	16.6	16.8	17.6	19.3
		40	17.5	18.3	18.5	18.5	18.5	19.1	20.3
45		18.3	19.6	20.2	20.4	20.5	20.9	21.9	
50				21.7	22.2	22.6	23.0	23.8	
55					23.8	24.5	25.1	26.0	
60					26.1	27.1	28.1		

*20°C Return gas temperature in non-shaded region

*11K Suction superheat in shaded region

*0K Subcooling

Performance data

Q=Capacity (kW) P=Power input (kW) 3-Phase

R404A

60 Hz

Model		Condensing temperature °C	Evaporating temperature (°C)						
			-20	-15	-10	-5	0	5	10
ZB190KQE	Q	10	59.8	64.2	73.9				
		15	59.3	63.6	72.8	86.5			
		20	58.1	62.1	70.9	83.9	100.4		
		25	56.3	59.9	68.3	80.6	96.3	114.6	
		30	53.9	57.2	65.1	76.7	91.5	108.7	127.8
		35	51.1	54.1	61.4	72.3	86.1	102.3	120.1
		40	48.1	50.7	57.4	67.6	80.5	95.4	111.9
		45	44.9	47.2	53.3	62.6	74.5	88.3	103.4
		50			49.1	57.6	68.5	81.1	94.7
	55				52.6	62.5	73.8	86.0	
	60					56.6	66.7	77.4	
	P	10	14.5	10.8	5.6				
		15	15.7	13.4	9.5	4.9			
		20	16.8	15.7	13.0	9.6	6.0		
		25	17.7	17.7	16.1	13.8	11.3	9.4	
		30	18.6	19.6	18.9	17.5	15.9	14.9	15.2
		35	19.5	21.2	21.4	20.7	19.9	19.6	20.7
		40	20.4	22.7	23.5	23.4	23.2	23.6	25.2
45		21.3	24.1	25.4	25.8	26.0	26.9	28.9	
50				27.0	27.7	28.3	29.4	31.8	
55				29.2	30.0	31.3	33.8		
60					31.2	32.5	35.1		
ZB220KQE	Q	10	73.5	86.5	101.4				
		15	68.3	81.5	96.7	113.8			
		20	63.0	76.1	91.4	108.6	127.6		
		25	58.0	70.7	85.6	102.5	121.4	142.0	
		30	53.5	65.4	79.7	96.0	114.4	134.6	156.5
		35	49.9	60.7	73.9	89.3	106.9	126.4	147.7
		40	47.3	56.7	68.5	82.7	99.1	117.6	138.0
		45	46.2	53.7	63.9	76.5	91.4	108.5	127.6
		50			60.3	71.0	84.1	99.5	116.9
	55				66.4	77.3	90.7	106.2	
	60					71.5	82.5	95.7	
	P	10	10.3	12.4	15.1				
		15	13.2	14.5	16.2	18.7			
		20	16.3	17.0	18.0	19.5	21.8		
		25	19.4	19.7	20.2	21.0	22.4	24.7	
		30	22.3	22.5	22.7	23.0	23.8	25.3	27.7
		35	24.8	25.2	25.3	25.4	25.8	26.7	28.3
		40	26.7	27.5	27.9	28.0	28.2	28.8	29.9
45		28.0	29.4	30.2	30.6	30.9	31.4	32.3	
50				32.1	33.1	33.7	34.3	35.2	
55				35.2	36.4	37.4	38.5		
60					38.9	40.5	42.0		

*20°C Return gas temperature in non-shaded region

*11K Suction superheat in shaded region

*0K Subcooling

Performance data

Q=Capacity (kW) P=Power input (kW) 1 & 3-Phase

R134a

60 Hz

Model		Condensing temperature °C	Evaporating temperature (°C)						
			-15	-10	-5	0	5	10	15
ZB15KQE	Q	30	2.3	2.9	3.6	4.5	5.4	6.5	
		35	2.2	2.8	3.5	4.2	5.2	6.3	
		45	2.0	2.4	3.2	3.9	4.7	5.7	6.8
		55		2.1	2.7	3.3	4.1	5.0	5.9
		65			2.2	2.8	3.5	4.2	5.1
		75				2.3	2.9	3.6	4.2
	P	30	1.0	1.0	1.0	1.0	1.0	1.0	
		35	1.0	1.0	1.0	1.1	1.1	1.1	
		45	1.2	1.2	1.2	1.3	1.3	1.3	1.3
		55		1.6	1.6	1.6	1.6	1.6	1.6
65				1.9	1.9	1.9	1.9	1.9	
ZB19KQE	Q	30	2.7	3.4	4.2	5.2	6.3	7.6	
		35	2.4	3.3	4.0	5.0	6.0	7.2	
		45	2.2	2.8	3.6	4.5	5.4	6.5	7.7
		55		2.4	3.0	3.8	4.7	5.7	6.9
		65			2.6	3.3	4.0	5.0	5.9
		75				2.7	3.3	4.1	4.8
	P	30	1.1	1.1	1.1	1.1	1.1	1.1	
		35	1.2	1.2	1.2	1.2	1.2	1.2	
		45	1.4	1.4	1.4	1.4	1.4	1.4	1.4
		55		1.8	1.8	1.8	1.8	1.8	1.8
65				2.2	2.2	2.3	2.3	2.3	
ZB21KQE	Q	30	3.4	4.2	5.3	6.5	7.8	9.5	
		35	3.3	4.0	5.1	6.2	7.5	9.0	
		45	2.8	3.5	4.5	5.6	6.8	8.2	9.8
		55		3.0	3.9	4.8	5.9	7.2	8.7
		65			3.3	4.1	5.1	6.2	7.5
		75				3.3	4.2	5.2	6.2
	P	30	1.3	1.3	1.3	1.3	1.3	1.3	
		35	1.4	1.4	1.4	1.4	1.4	1.4	
		45	1.8	1.8	1.8	1.8	1.8	1.8	1.8
		55		2.2	2.2	2.2	2.3	2.3	2.3
65				2.6	2.8	2.8	2.8	2.8	
ZB26KQE	Q	30	3.9	5.0	6.2	7.5	9.2	11.0	
		35	3.6	4.7	5.8	7.1	8.7	10.5	
		45	3.2	4.0	5.2	6.4	7.8	9.4	11.3
		55		3.5	4.5	5.6	6.9	8.3	10.0
		65			3.8	4.7	5.9	7.1	8.6
		75				3.9	4.8	6.0	7.1
	P	30	1.4	1.4	1.4	1.4	1.4	1.6	
		35	1.6	1.6	1.7	1.7	1.7	1.7	
		45	2.0	2.0	2.0	2.0	2.0	2.0	2.0
		55		2.5	2.5	2.5	2.5	2.5	2.5
65				3.1	3.1	3.1	3.1	3.1	
ZB29KQE	Q	30	4.6	5.7	7.1	8.7	10.5	12.6	
		35	4.2	5.4	6.7	8.2	10.0	12.1	
		45	3.7	4.7	6.0	7.4	9.0	10.8	12.1
		55		4.0	5.1	6.3	7.9	9.5	10.7
		65			4.8	5.4	6.7	8.2	9.2
		75				4.3	5.5	6.8	7.5
	P	30	1.6	1.7	1.7	1.7	1.7	1.7	
		35	1.9	1.9	1.9	1.9	1.9	1.9	
		45	2.3	2.3	2.3	2.4	2.4	2.4	2.4
		55		2.9	2.9	2.9	2.9	2.9	3.0
65				3.6	3.6	3.6	3.7	3.7	
75				4.5	4.5	4.5	4.5		

*20°C Return gas temperature in non-shaded region

*11K Suction superheat in shaded region

*0K Subcooling

Performance data

Q=Capacity (kW) P=Power input (kW) 1 & 3-Phase

R134a

60 Hz

Model		Condensing temperature °C	Evaporating temperature (°C)						
			-15	-10	-5	0	5	10	15
ZB38KQE	Q	30	5.7	7.1	8.9	11.0	13.4	16.0	
		35	5.2	6.8	8.4	10.4	12.6	15.3	
		45	4.6	5.9	7.6	9.4	11.3	13.7	16.5
		55		5.1	6.5	8.1	10.0	12.2	14.6
		65			5.6	6.9	8.6	10.5	12.5
		75				5.6	7.0	8.7	10.7
	P	30	2.0	2.0	2.0	2.2	2.2	2.2	
		35	2.3	2.3	2.3	2.4	2.4	2.4	
		45	2.8	2.9	2.9	2.9	2.9	3.0	3.0
		55		3.6	3.6	3.6	3.6	3.6	3.7
65				4.4	4.4	4.4	4.6	4.6	
ZB45KQE	Q	30	6.9	8.6	10.7	13.1	16.0	19.1	
		35	6.3	8.2	10.2	12.5	15.3	18.3	
		45	5.4	7.0	9.0	11.2	13.7	16.5	19.6
		55		6.0	7.6	9.6	12.0	14.6	17.3
		65			6.4	8.1	10.1	12.4	14.8
		75				6.5	8.2	10.2	12.2
	P	30	2.4	2.4	2.4	2.4	2.4	2.4	
		35	2.6	2.6	2.6	2.6	2.8	2.8	
		45	3.2	3.2	3.4	3.4	3.4	3.4	3.4
		55		4.1	4.1	4.2	4.2	4.2	4.2
65				5.2	5.2	5.2	5.3	5.3	
ZB48KQE	Q	30	7.7	9.7	11.9	14.6	17.6	21.2	
		35	7.1	9.2	11.3	13.9	16.8	20.3	
		45	6.3	8.0	10.2	12.5	15.1	18.2	20.8
		55		6.9	8.7	10.8	13.3	16.0	18.3
		65			7.3	9.2	11.3	13.8	15.8
		75				7.5	9.4	11.5	13.1
	P	30	2.7	2.8	2.8	2.8	2.8	2.8	
		35	3.1	3.1	3.1	3.1	3.1	3.2	
		45	3.8	3.8	3.9	3.9	3.9	4.0	4.0
		55		4.8	4.8	4.8	4.9	4.9	5.0
65				6.0	6.0	6.1	6.1	6.1	
ZB58KQE	Q	30	9.0	11.1	13.4	16.1	19.1	22.3	
		35	7.5	10.5	12.7	15.3	18.1	21.2	
		45	6.5	8.3	11.3	13.6	16.2	18.9	22.0
		55		7.1	8.9	11.2	14.0	16.5	19.2
		65			7.4	9.3	11.6	13.9	16.2
		75				7.3	9.2	11.5	13.1
	P	30	3.2	3.3	3.3	3.4	3.5	3.5	
		35	3.6	3.6	3.7	3.8	3.8	3.8	
		45	4.5	4.5	4.6	4.6	4.7	4.7	4.6
		55		5.5	5.6	5.7	5.7	5.7	5.6
65				6.8	6.9	6.9	7.0	6.9	
ZB66KQE	Q	30	10.3	12.6	15.3	18.4	21.8	25.5	
		35	8.6	11.9	14.5	17.5	20.7	24.3	
		45	7.5	9.5	12.9	15.5	18.6	21.7	25.1
		55		8.1	10.2	12.8	16.0	18.9	21.9
		65			8.4	10.6	13.2	15.9	18.5
		75				8.4	10.6	13.1	15.0
	P	30	3.6	3.6	3.7	3.8	3.9	3.9	
		35	4.0	4.1	4.1	4.2	4.3	4.3	
		45	5.0	5.0	5.1	5.2	5.2	5.2	5.1
		55		6.2	6.3	6.3	6.4	6.4	6.3
65				7.6	7.7	7.8	7.8	7.7	

*20°C Return gas temperature in non-shaded region

*11K Suction superheat in shaded region

*0K Subcooling

Performance data

Q=Capacity (kW) P=Power input (kW) 1 & 3-Phase

R134a

60 Hz

Model		Condensing temperature °C	Evaporating temperature (°C)						
			-15	-10	-5	0	5	10	15
ZB76KQE	Q	30	11.8	14.5	17.6	21.1	21.1	29.2	
		35	9.8	13.7	16.7	20.0	20.0	27.8	
		45	8.5	10.8	14.7	17.8	17.8	24.8	28.7
		55		9.2	11.7	14.6	14.6	21.6	25.1
		65			9.7	12.1	12.1	18.2	21.2
		75				9.6	9.6	15.0	17.2
	P	30	4.2	4.3	4.3	4.4	4.4	4.6	
		35	4.7	4.8	4.8	4.9	4.9	5.0	
		45	5.8	5.9	6.0	6.0	6.0	6.1	6.0
		55		7.2	7.3	7.4	7.4	7.4	7.3
		65			8.8	9.0	9.0	9.0	8.9
		75				10.7	10.7	10.9	10.8

*20°C Return gas temperature in non-shaded region

*11K Suction superheat in shaded region

*0K Subcooling

Technical data

Compressor model			ZB Refrigeration scroll 2-7HP								
			ZB15KQ/E	ZB19KQ/E	ZB21KQ/E	ZB26KQ/E	ZB29KQ/E	ZB38KQ/E	ZB45KQ/E	ZB48KQ/E	
Nominal horsepower	HP		2	2.5	3	3.5	4	5	6	7	
Displacement	50 Hz	m ³ /hr	5.9	6.8	8.6	9.9	11.4	14.4	17.1	18.8	
	60 Hz	m ³ /hr	7.1	8.2	10.4	12.0	13.8	17.3	20.6	22.6	
Motor type	50 Hz	220-240V-1ph	PFJ	PFJ	PFJ	PFJ	PFJ				
		380-420V-3ph	TFD	TFD	TFD	TFD	TFD	TFD	TFD	TFD	
		200-220V-3ph	TF5	TF5	TF5	TF5	TF5	TF5	TF5	TF5	
	60 Hz	208-230V-1ph	PFV	PFV	PFV	PFV	PFV	PFV			
		460V-3ph	TFD	TFD	TFD	TFD	TFD	TFD	TFD	TFD	
		200-230V-3ph	TF5	TF5	TF5	TF5	TF5	TF5	TF5	TF5	
		380V-3ph	TF7	TF7	TF7	TF7	TF7	TF7	TF7	TF7	
Run capacitor (Single phase)	50 Hz	PFJ	μF / V	40/440	45/370	60/370	60/370	60/370			
		PFV		40/370	45/370	50/370	60/370	60/440	80/370		
Locked rotor current (LRA)	50 Hz	PFJ	Amps	58.0	61.0	82.0	97.0	114.0			
		TF5/TW5		56.0	70.0	83.0	95.0	98.0	139.0	172.0	179.0
		TFD		26.0	32.0	40.0	46.0	50.0	65.5	74.0	101.0
	60 Hz	PFV	Amps	61.0	72.5	95.0	109.0	137.0	144.0		
		TF5/TW5		55.0	63.0	77.0	88.0	91.0	128.0	156.0	164.0
		TF7/TW7		27.0	30.0	39.0	41.0	54.0	64.0	70.0	100.0
		TFD	27.0	31.0	39.0	44.0	50.0	63.0	75.0	100.0	
Rated load current (RLA)	KQ	PFJ	Amps	11.4	12.9	16.4	17.1	19.3			
		PFV		13.6	15.0	18.4	20.4	22.1	30.1		
		TF5/TW5		8.9	10.0	11.4	13.9	16.4	20.7	20.7	25.0
		TF7/TW7		5.0	5.8	7.5	7.3	9.3	10.7	10.7	12.1
		TFD		4.3	4.3	5.7	7.1	7.9	10.0	11.5	12.1
	KQE	PFJ	Amps	13.2	14.6	15.4	18.9	20.0			
		PFV		15.7	17.1	20.7	23.6	25.0	30.8		
		TF5/TW5		8.9	10.0	12.1	13.2	17.1	24.0	26.0	26.0
		TF7/TW7	5.1	5.9	7.4	7.6	9.6	12.4	12.6	17.1	
		TFD	5.0	5.0	7.4	6.4	7.9	9.6	10.1	13.6	
Maximum continuous current (MCC)	KQ	PFJ	Amps	16.0	18.0	23.0	24.0	27.0			
		PFV		19.0	21.0	25.8	28.6	31.0	42.2		
		TF5/TW5		12.5	14.0	16.0	19.4	23.0	29.0	29.0	35.0
		TF7/TW7		7.0	8.1	10.5	10.2	13.0	15.0	15.0	17.0
		TFD		6.0	6.0	8.0	10.0	11.0	13.5	16.1	17.0
	KQE	PFJ	Amps	18.5	20.5	21.5	26.5	28.0			
		PFV		22.0	24.0	29.0	33.0	35.0	43.3		
		TF5/TW5		12.5	14.0	17.0	18.5	24.0	33.6	32.4	36.4
		TF7/TW7	7.2	8.3	10.3	10.7	13.5	17.4	17.7	24.0	
		TFD		7.0	10.3	9.0	11.0	14.0	14.2	19.1	
Connection size	Suction	in	Rotalock connection								
			1-1/4	1-1/4	1-1/4	1-1/4	1-1/4	1-1/4	1-1/4	1-1/4	
	Discharge	in	Brazing connection								
			3/4	3/4	3/4	3/4	7/8	7/8	7/8	7/8	
	Suction	in	1/2	1/2	1/2	1/2	1/2	1/2	1/2	1/2	3/4
Outline dimension	Length	mm	242	242	243	243	242	242	242	242	
	Width		242	242	244	244	242	242	242	242	
	Height			389	412	425	430	457	457	457	
Sight glass fitting thread	in	1-1/4 X 12UNF									
Oil type		KQ: Mineral oil; KQE: POE									
Oil quantity	L	1.3	1.3	1.24	1.48	1.36	2.07	1.77	1.77		
Net weight	kg	23	25	27	28	33	38	40	40		
Terminal box IP grade		21	21	21	21	21	21	21	21		
Crankcase heater power	W	70	70	70	70	70	70	70	70		
Mounting parts installation size (Hole size)	mm	190X190 (Ø8.5)									

Technical data

Compressor model			ZB Refrigeration scroll 7-15HP						
			ZB58KQ/E	ZB66KQ/E	ZB76KQ/E	ZB88KQ	ZB95KQ/E	ZB114KQ/E	
Nominal horsepower	HP		8	9	10	12	13	15	
Displacement	50 Hz	m ³ /hr	22.0	25.7	28.8	33.2	36.4	43.3	
	60 Hz	m ³ /hr	26.7	31.0	34.8	40.1	43.9	52.3	
Motor type	50 Hz	220-240V-1ph							
		380-420V-3ph	TFD	TFD	TFD	TFD	TFD	TFD	
		200-220V-3ph	TF5	TF5	TF5	TF5	TW5	TW5	
	60 Hz	208-230V-1ph							
		460V-3ph	TFD	TFD	TFD	TFD	TFD	TFD	
		200-230V-3ph	TF5	TF5	TF5	TF5	TW5	TW5	
	380V-3ph	TF7	TF7	TF7	TF7	TW7	TW7		
Run capacitor (Single phase)	50 Hz	PFJ	μF / V						
		PFV							
Locked rotor current (LRA)	50 Hz	PFJ	Amps						
		TF5/TW5		203.0	231.0	239.0	273.0		
		TFD		95.0	111.0	118.0	118.0	140.0	174.0
	60 Hz	PFV	Amps						
		TF5/TW5		195.0	225.0	239.0	245.0	300.0	340.0
		TF7/TW7		123.0	140.0	145.0	145.0	139.0	196.0
	TFD	95.0	114.0	125.0	125.0	150.0	179.0		
Rated load current (RLA)	KQ	PFJ	Amps						
		PFV							
		TF5/TW5		32.1	33.6	41.4	47.1	53.6	58.6
		TF7/TW7		16.7	18.6	23.6	24.4	28.6	35.7
	KQE	TFD	16.4	17.3	20.0	22.1	25.0	27.9	
		PFJ							
		PFV							
		TF5/TW5	32.1	33.6	41.4	61.4	65.0		
	TF7/TW7	18.6	23.6	35.0	42.9				
	TFD	16.4	17.3	20.0	26.4	28.6			
	Maximum continuous current (MCC)	KQ	PFJ	Amps					
			PFV						
TF5/TW5			45.0		47.0	54.0	66.0	75.0	82.0
TF7/TW7		23.4	26.0		33.1	34.2	40.0	50.0	
TFD		23.0	24.2		26.9	31.0	35.0	42.0	
KQE	PFJ								
	PFV								
	TF5/TW5	43.0	44.0	58.0	86.0	91.0			
	TF7/TW7	29.0	33.0	49.0	60.0				
	TFD	23.0	24.5	28.0	37.0	40.0			
Connection size	Suction	in	Rotalock connection						
			1-3/4	1-3/4	1-3/4	1-3/4	1-3/4	1-3/4	
	Discharge	in	Brazing connection						
			1-1/4	1-1/4	1-1/4	1-1/4	1-1/4	1-1/4	
	Suction	in	1-1/8	1-3/8	1-3/8	1-3/8	1-3/8	1-3/8	
7/8			7/8	7/8	7/8	7/8	7/8		
Outline dimension	Length	mm	264	264	264	264	264	264	
	Width	mm	284	284	284	284	285	285	
	Height	mm	477	546	546	546	552	553	
Sight glass fitting thread	in	1-1/4 X 12UNF							
Oil type		KQ: Mineral oil; KQE: POE							
Oil quantity	L	2.5	3.25	3.25	3.25	3.3	3.3		
Net weight	kg	57	59	62	62	62	63		
Terminal box IP grade		21	21	21	21	21	21		
Crankcase heater power	W	90	90	90	90	90	90		
Mounting parts installation size (Hole size)	mm	190X190 (Ø8.5)							

Technical data

Compressor model			ZB Large refrigeration scroll 20-30HP														
			ZB130KQ		ZB130KQE		ZB150KQ		ZB150KQE		ZB190KQ		ZB190KQE		ZB220KQ		ZB220KQE
Nominal horsepower		HP	20		22		25		30								
Displacement	50 Hz	m ³ /hr	45.7		56.6		71.4		87.5								
	60 Hz	m ³ /hr	55.2		68.3		86.2		105.5								
Motor type	50 Hz	380-420V-3ph	TED	TED	TWD	TWD	TWD	TWD	TWD	TWD	TWD	TWD	TWD	TWD	TWD	TWD	TWD
		200V-3ph	TEC	TEC	TWC	TWC	TWC	TWC	TWC	TWC	TWC	TWC	TWC	TWC	TWC	TWC	TWC
	60 Hz	460V-3ph	TED	TED	TWD	TWD	TWD	TWD	TWD	TWD	TWD	TWD	TWD	TWD	TWD	TWD	TWD
		208-230V-3ph	TEC	TEC	TWC	TWC	TWC	TWC	TWC	TWC	TWC	TWC	TWC	TWC	TWC	TWC	TWC
		380V-3ph	TE7	TE7	TW7	TW7	TW7	TW7	TW7	TW7	TW7	TW7	TW7	TW7	TW7	TW7	TW7
Refrigerant			R22	R404A	R22	R404A	R22	R404A	R22	R404A	R22	R404A	R22	R404A	R22	R404A	
Locked rotor current (LRA)	50 Hz	TED/TWD	287.5		225		272		310								
		TEC/TWC			505		610		599								
	60 Hz	TED/TWD	280.7		225		272		310								
		TEC/TWC			505		610		599								
		TE7/TW7	343.1		290		353		358								
Rated load current	50 Hz	TED/TWD	37.4		33.6	31.4	41.4	41.4	54.3	64.3							
		TEC/TWC			81.4	76.2	100.5	100.5	131.6	155.9							
	60 Hz	TED/TWD	40.64		33.6	31.4	41.4	41.4	54.3	64.3							
		TEC/TWC			81.4	76.2	100.5	100.5	111.4	131.9							
		TE7/TW7	36.5		42.1	39.4	55.7	55.7	63.1	74.8							
Maximum continuous current (MCC)	50 Hz	TED/TWD	52.3		47.0	44.0	58.0	58.0	76.0	90.0							
		TE7/TW7			114.0	106.7	140.7	140.7	184.3	218.3							
	60 Hz	TED/TWD	56.9		47.0	44.0	58.0	58.0	76.0	90.0							
		TEC/TWC			114.0	106.7	140.7	140.7	156.0	184.7							
		TE7/TW7	51.1		59.0	55.2	78.0	78.0	88.4	104.7							
Connection size			Rotolock connection														
	Suction	in	2-1/4 x 12UN														
	Discharge		1-3/4 x 12UN														
			Brazing connection														
	Suction	in	1-5/8														
	Discharge		1-1/8	1-3/8													
Outline dimension	Length	mm	315		432		448		448								
	Width		315		376		392		392								
	Height		662		717		715		715								
Sight glass fitting thread		in	1-3/4" x 12 UNF														
Oil type			Mineral	POE	Mineral	POE	Mineral	POE	Mineral	POE	Mineral	POE	Mineral	POE	Mineral	POE	
Oil quantity		L	4.4		4.7		6.8		6.3								
Net weight		kg	91.7		140		160		177								
Terminal box IP grade			IP54		IP56		IP56		IP56								
Crankcase heater power		W	90		150		150		150								
Mounting parts installation size (Hole size)		mm	232.0X232.0 (Ø22.6)			266.7 x 266.7 (Ø22.6)											

Dimensional drawings

ZB15-ZB29KQ/KQE

Brazing (BOM 558)

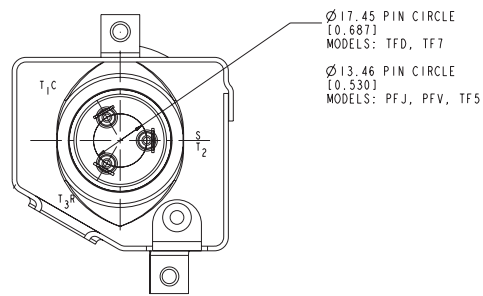
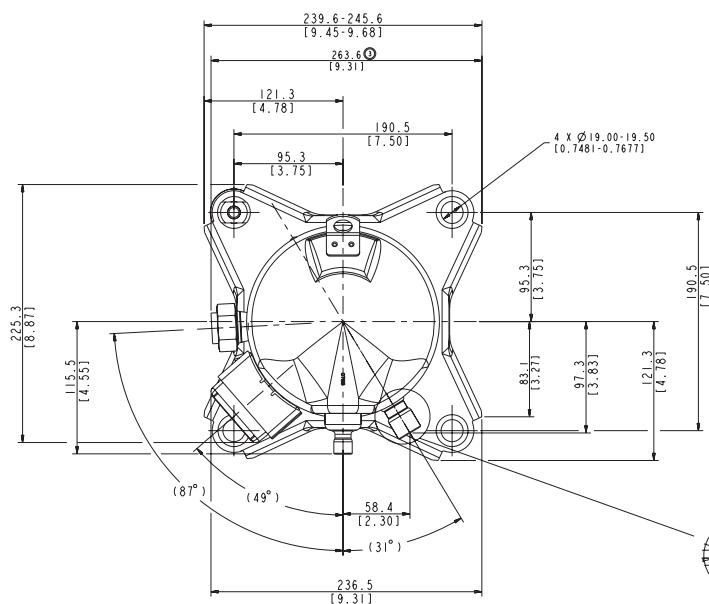

SCALE 2:1

G: COPPER PLATED STEEL
SUCTION FITTING
 \varnothing 22.30 - 22.48
[0.8780 - 0.8850] I.D.
 \varnothing 20.40 [0.8031] MIN.
 \varnothing 0.038 [0.0015] MIN THICK EXTERIOR AND
0.038 [0.0015] MIN THICK INTERIOR

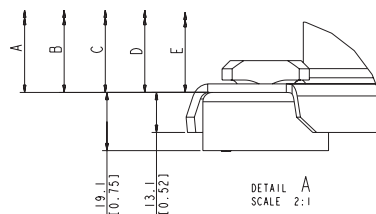
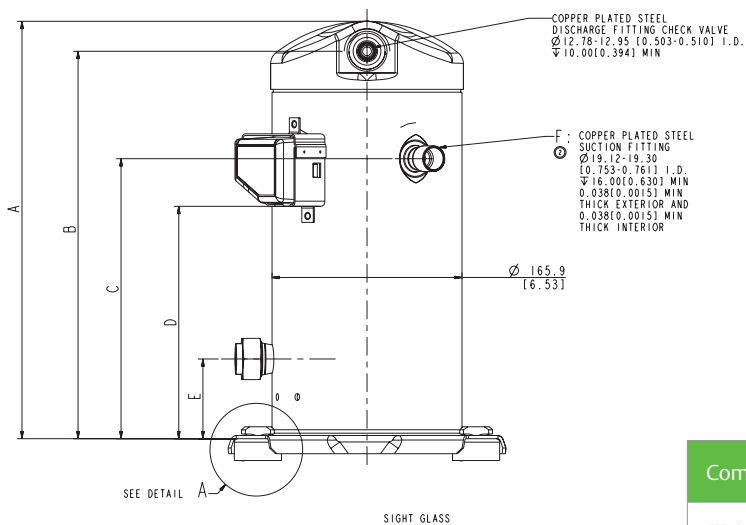

Compressor model	A \pm 3	B \pm 3	C \pm 3	D \pm 3	E \pm 3
ZB15KQ/ZB15KQE	363.8	338.3	244.5	202.9	69.6
ZB19KQ/ZB19KQE					
ZB21KQ/ZB21KQE	386.4	360.9	264.4	222.8	64.9
ZB26KQ/ZB26KQE	400.2	372.9	277.1	235.5	77.6
ZB29KQ/ZB29KQE	417.8	389.9	294.1	252.5	67.4

Dimensional drawings

ZB58KQ/KQE

Brazing (BOM 550)

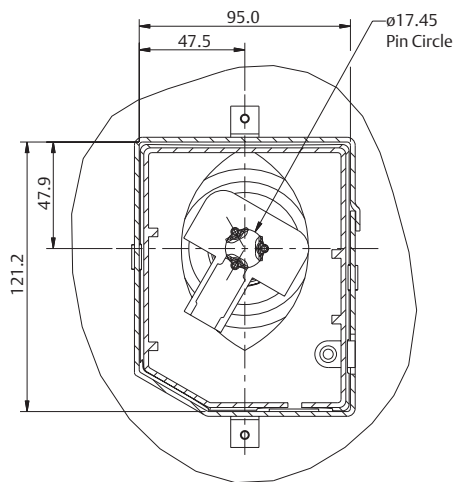
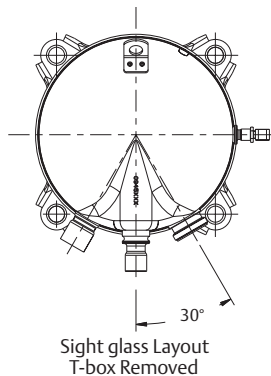
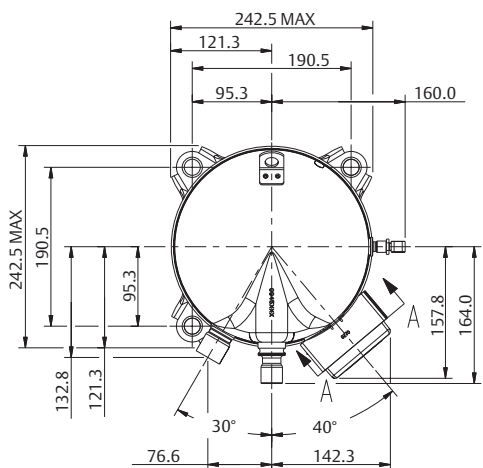

T-Box layout
Standard
Section A-A
Scale 1:1

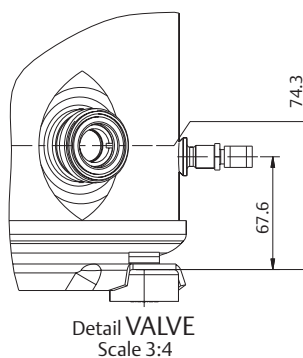
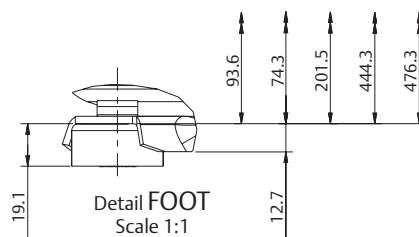
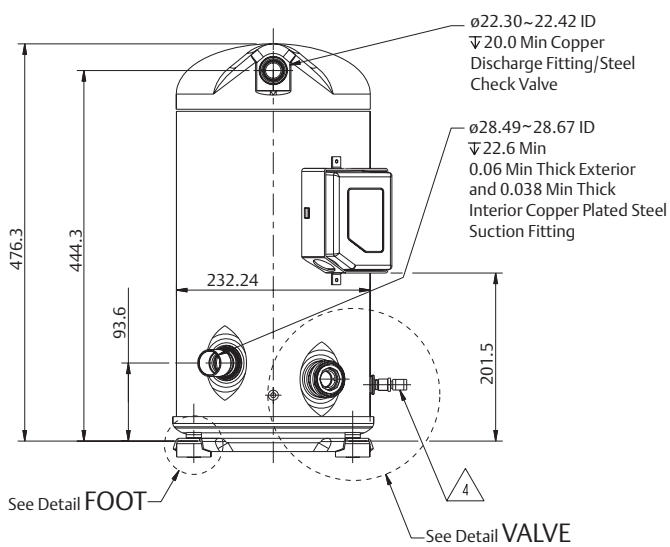

Dimensional drawings

ZB66-ZB88KQ/KQE

Brazing (BOM 550)

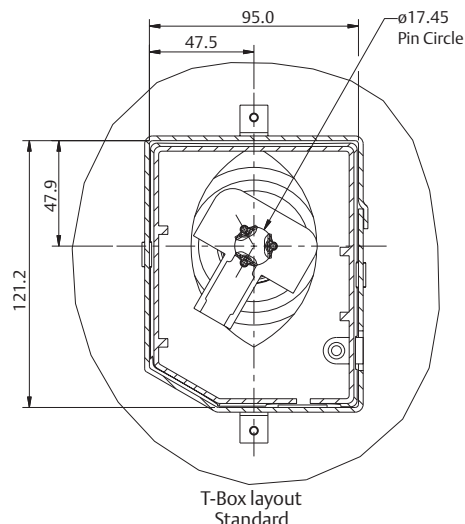
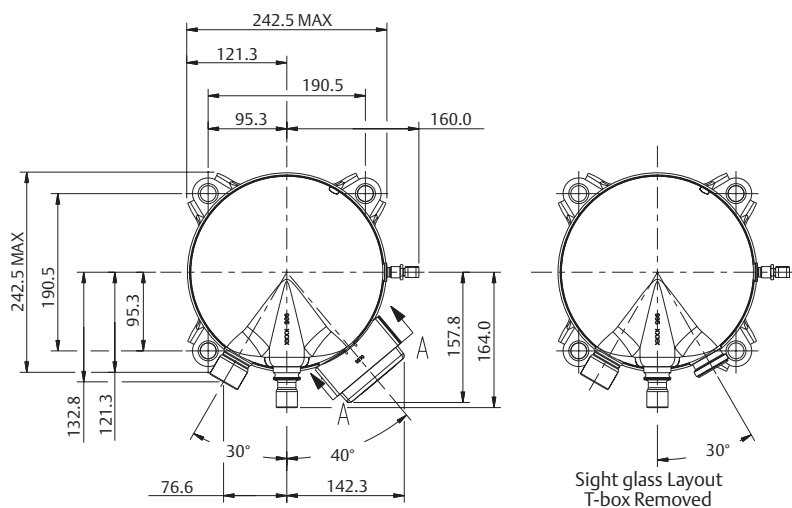

Section A-A
Scale 1:1

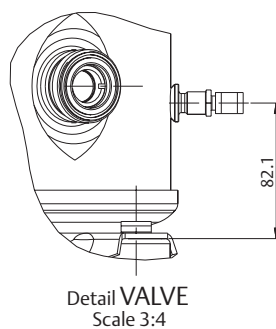
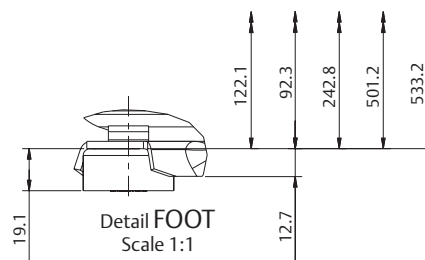
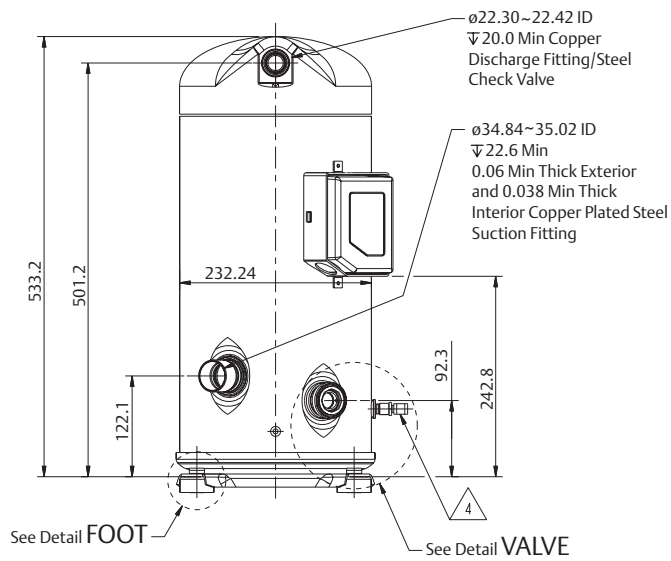

Dimensional drawings

ZB95-ZB114KQ/KQE

Brazing (BOM 550)

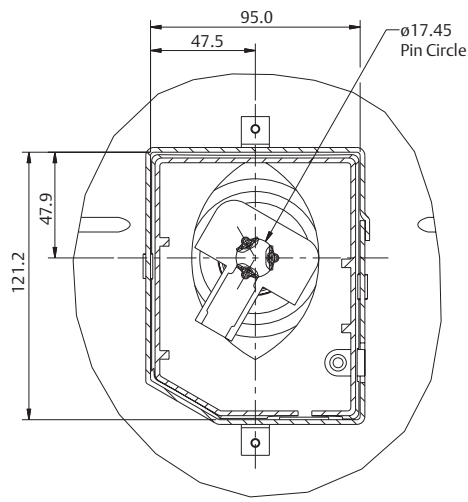
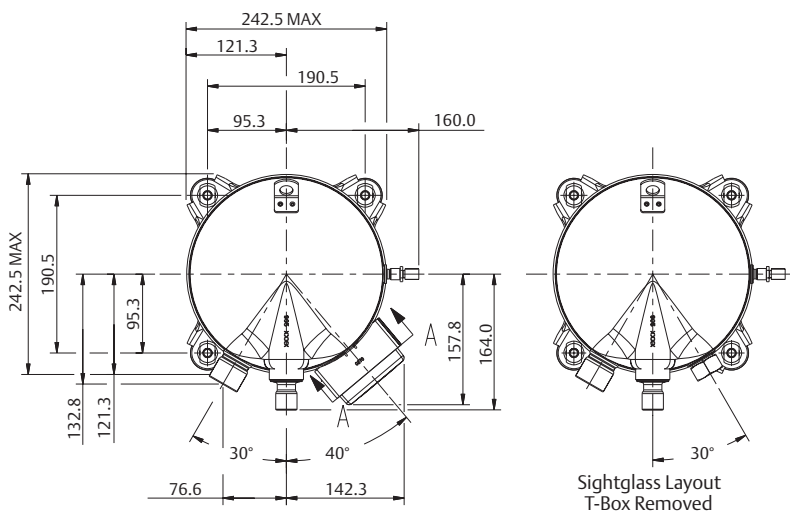

T-Box Layout
Standard
Section A-A
Scale 1:1

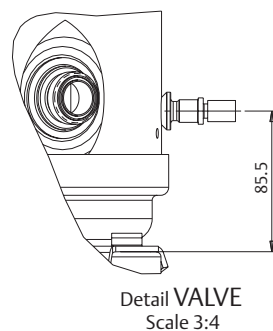
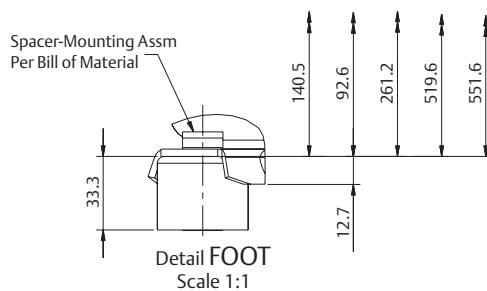
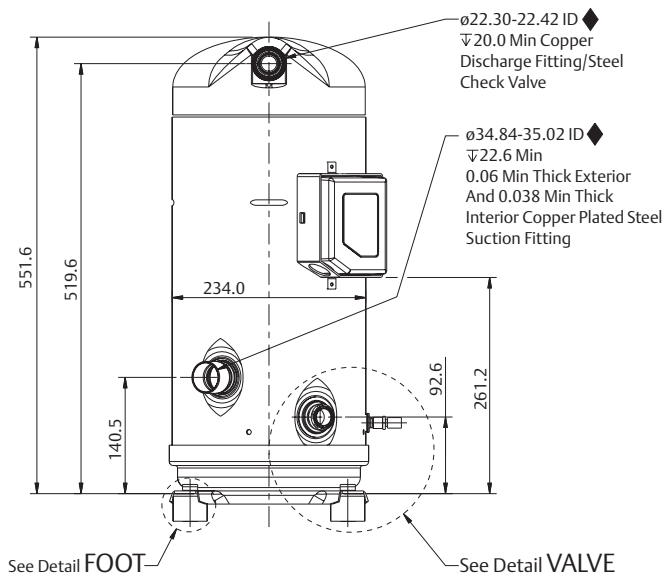

Dimensional drawings

ZB95-ZB114KQ/KQE (TW7/TW5)

Brazing (BOM 550)

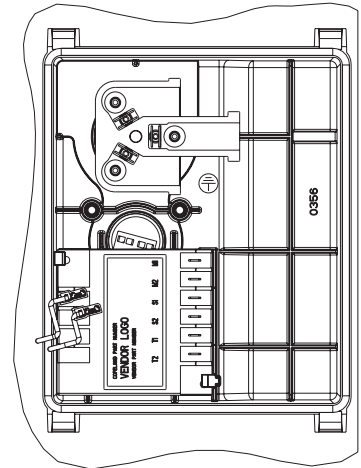
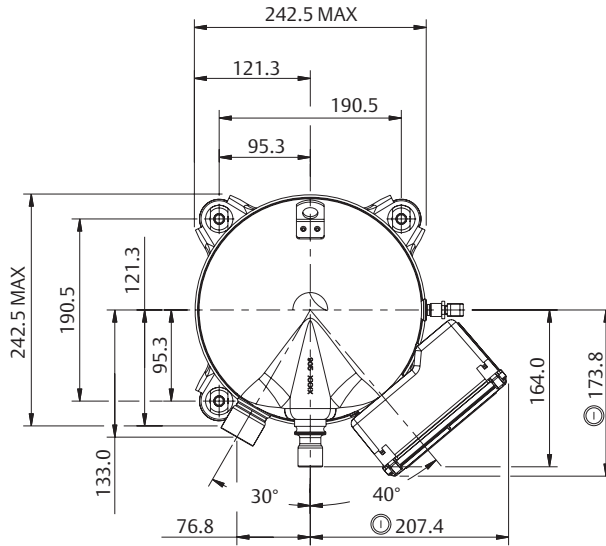

Terminal Box layout Standard ©
Scale 3:4

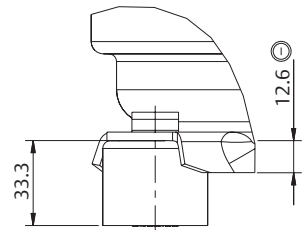
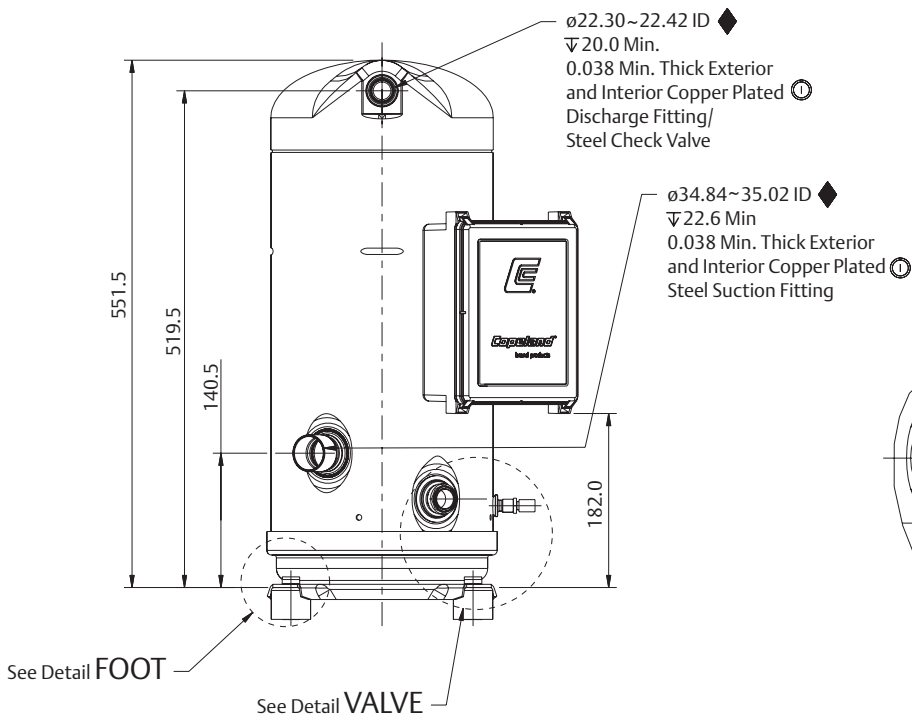

Detail FOOT
Scale 1:1

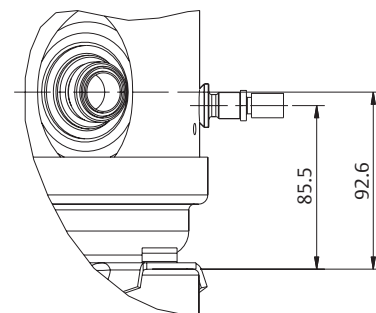

Detail VALVE
Scale 3:4

Dimensional drawings

ZB15-ZB29KQ/KQE

Rotalock (BOM 559)

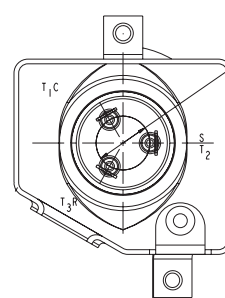
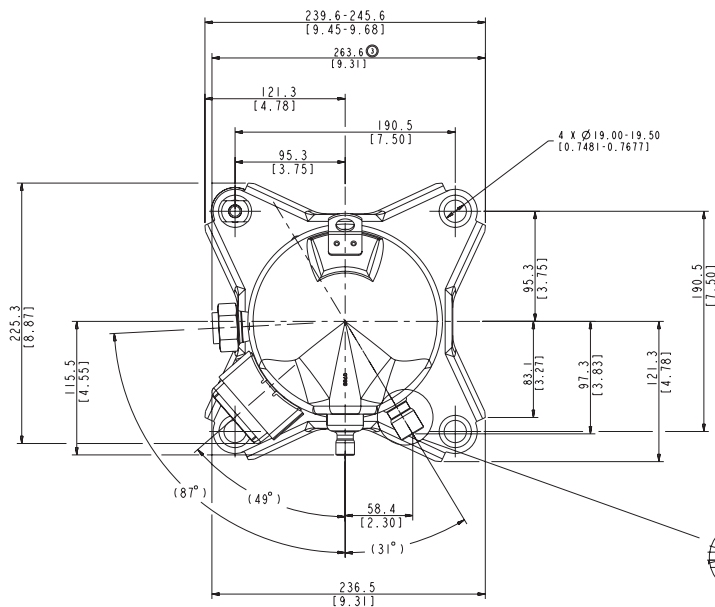

SCALE 2:1



G: COPPER PLATED STEEL SUCTION FITTING
 Ø22.30 - 22.48 [0.8780 - 0.8850] I.D.
 Ψ20.40 [0.803] MIN.
 0.038[0.0015] MIN THICK EXTERIOR AND 0.038[0.0015] MIN THICK INTERIOR

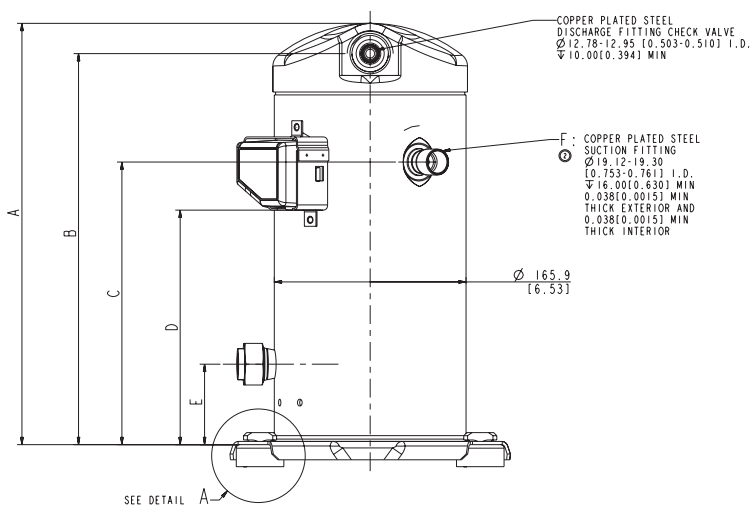

SIGHT GLASS

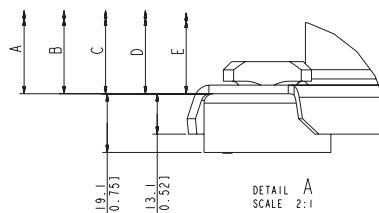

Dimensional drawings

ZB38-ZB48KQ/KQE

Rotalock (BOM 559)

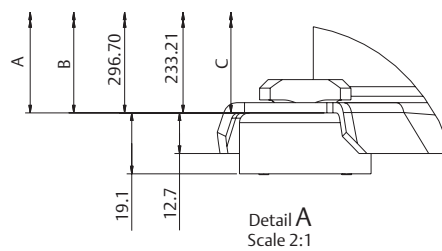
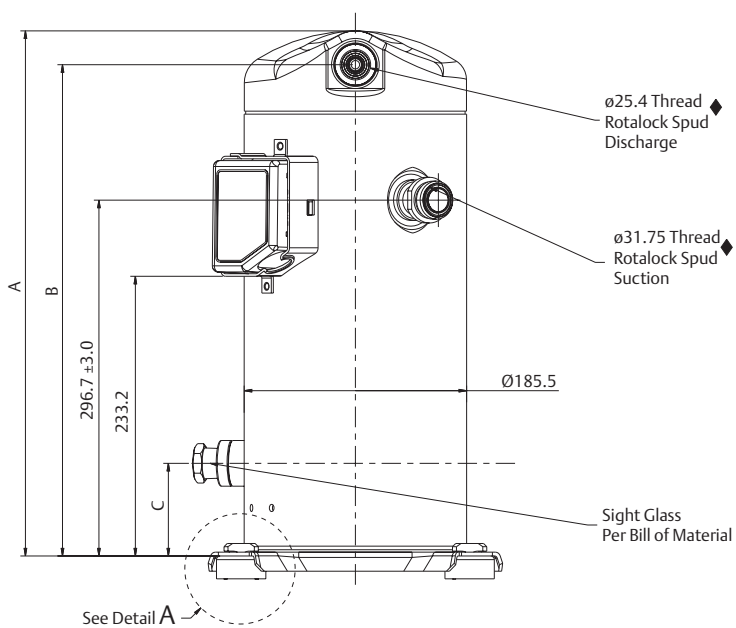
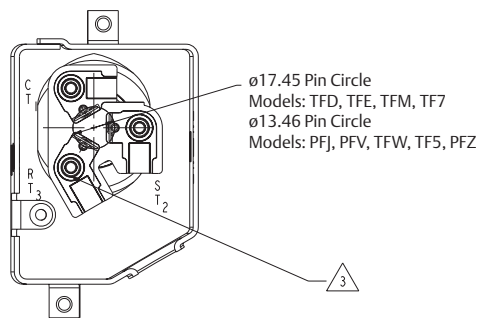
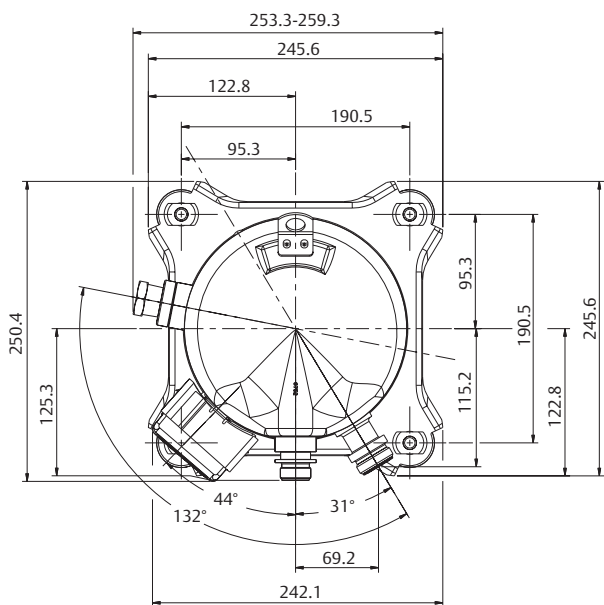

Dimensional drawings

ZB58KQ/KQE
Rotalock (BOM 551)

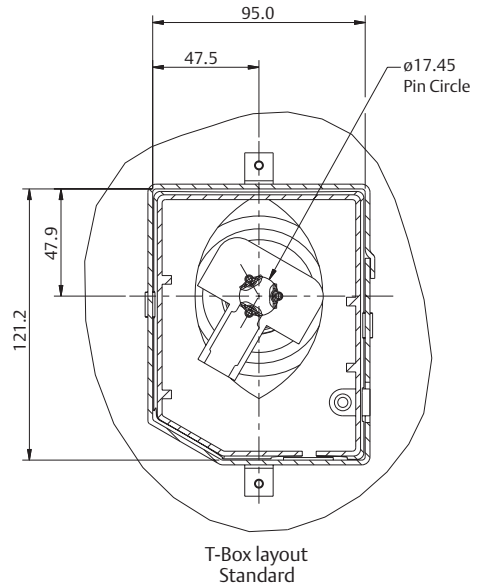
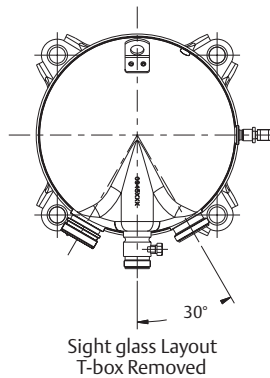
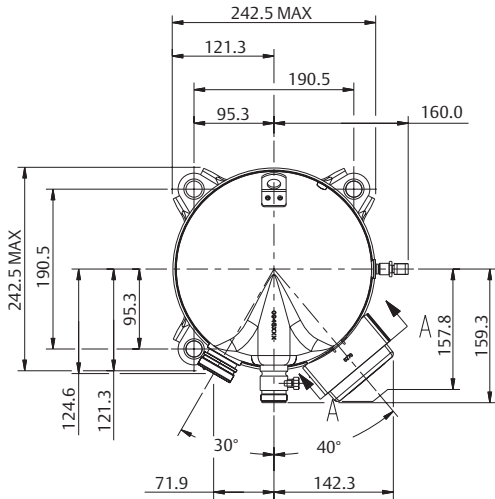

Section A-A
Scale 1:1

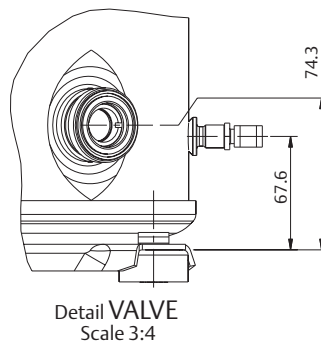
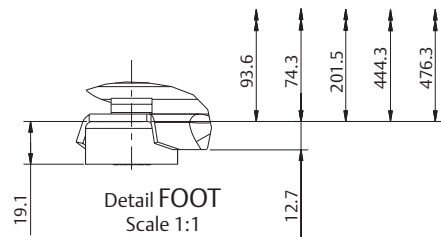
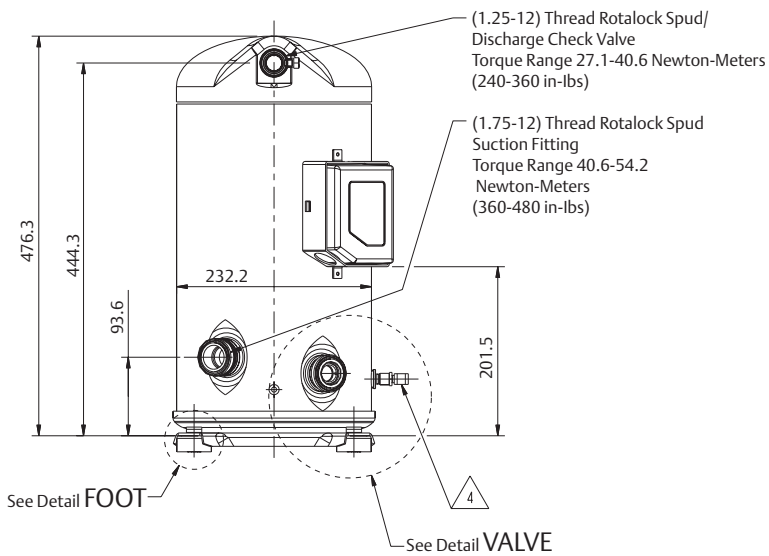

Dimensional drawings

ZB66-ZB88KQ/KQE
Rotalock (BOM 551)

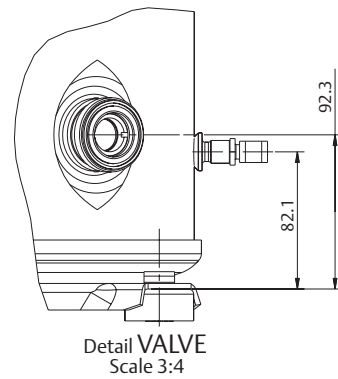
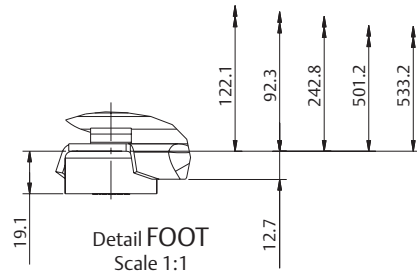
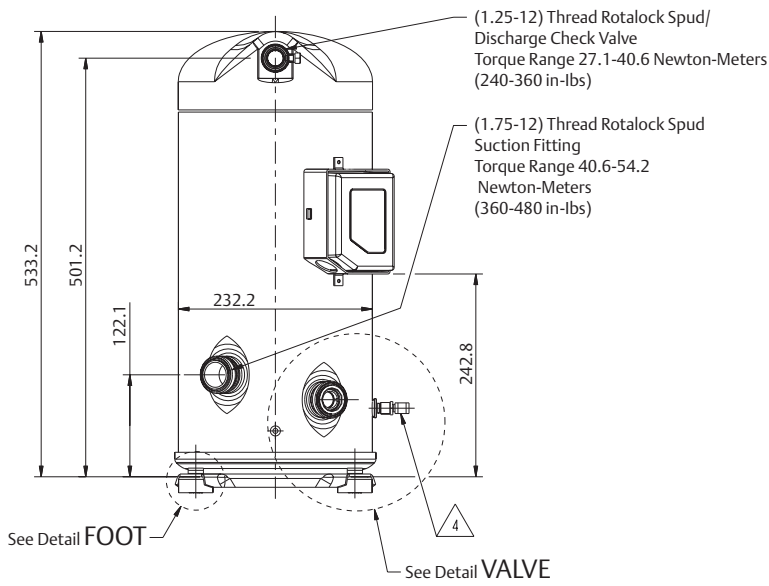
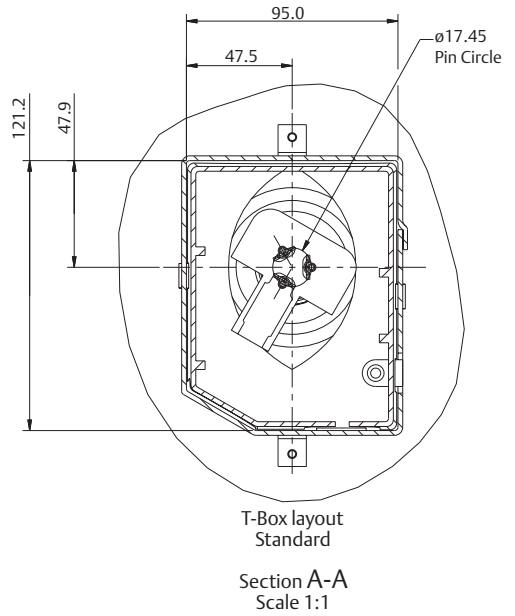
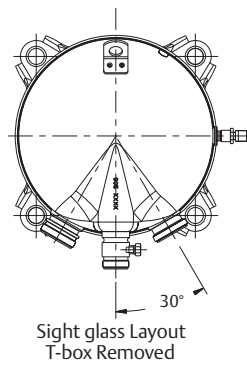
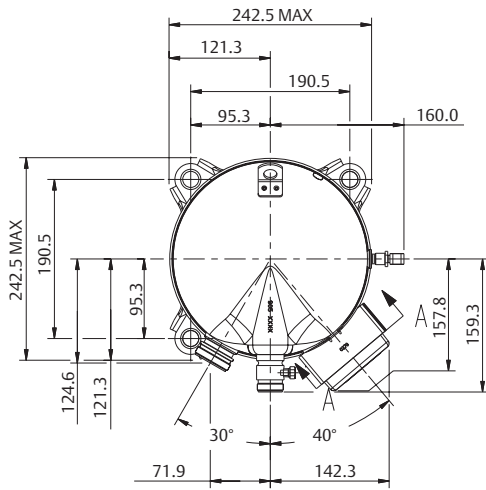

Dimensional drawings

ZB95-ZB114KQ/KQE

Rotalock (BOM 551)

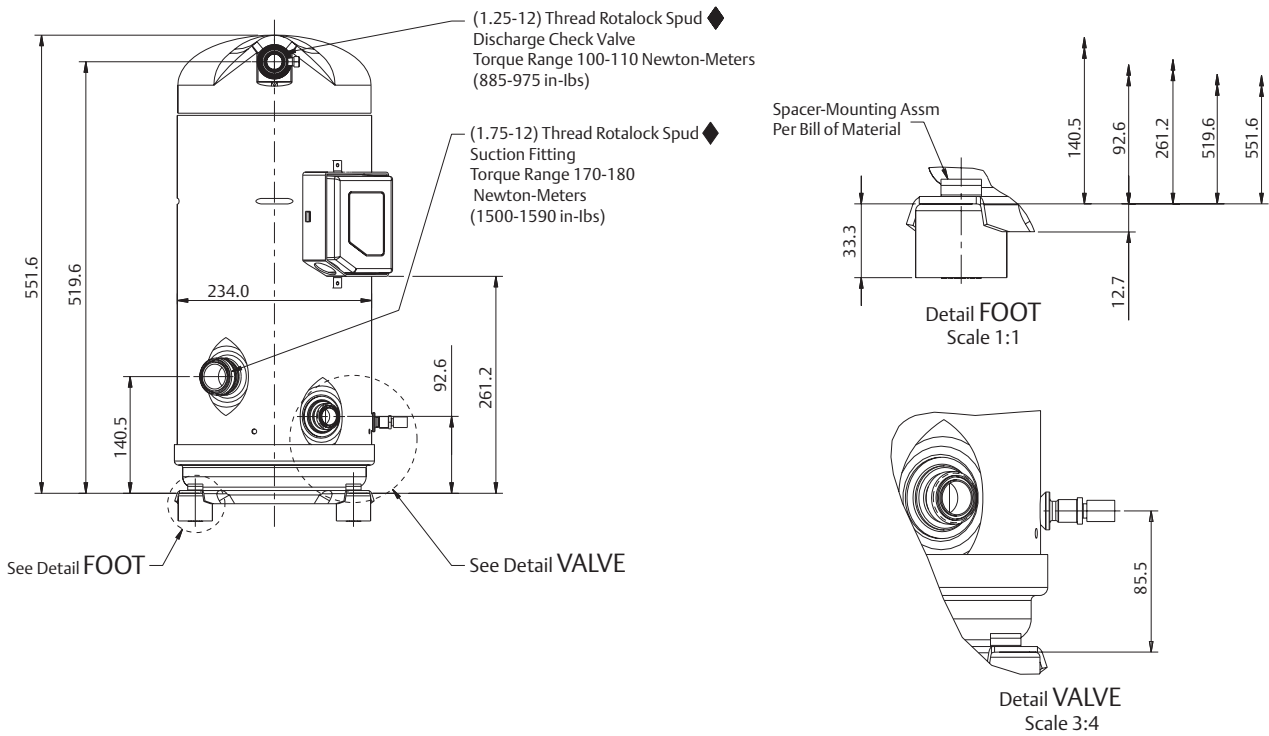
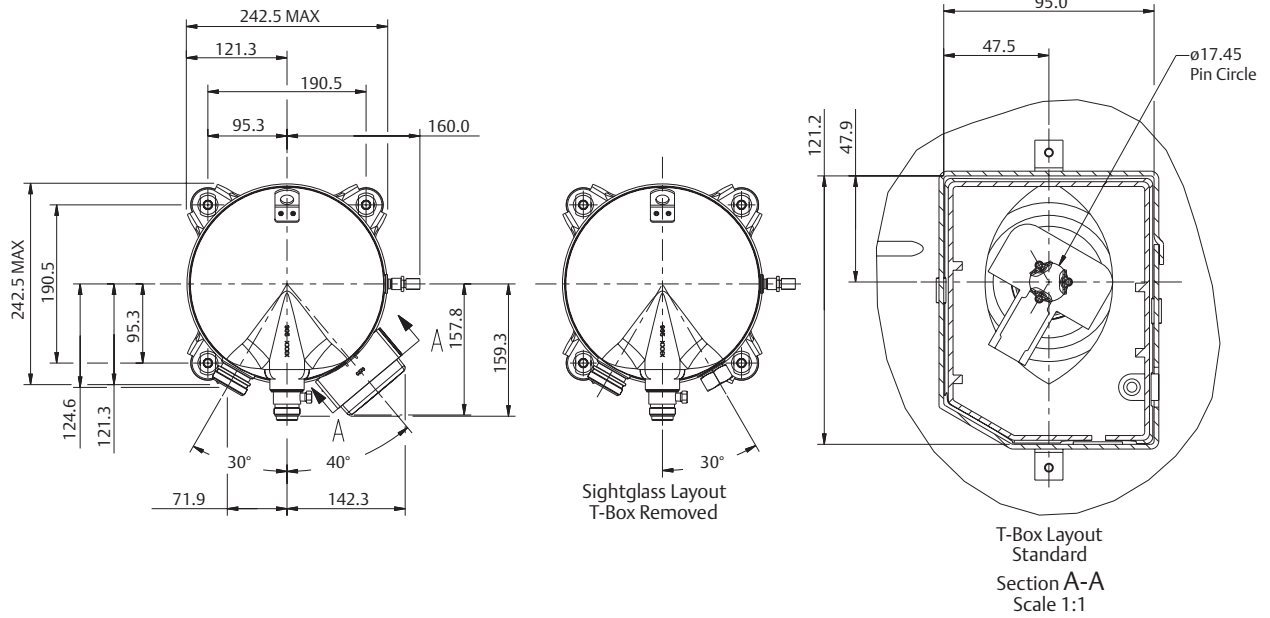

Dimensional drawings

ZB95-ZB114KQ/KQE (TW7/TW5)

Rotalock (BOM 551)

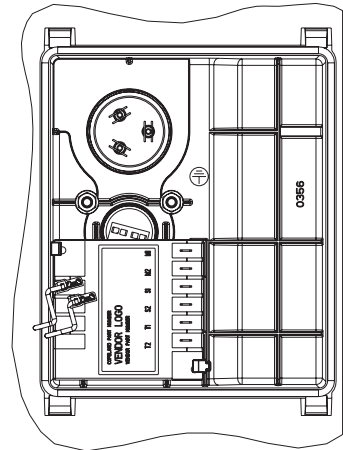
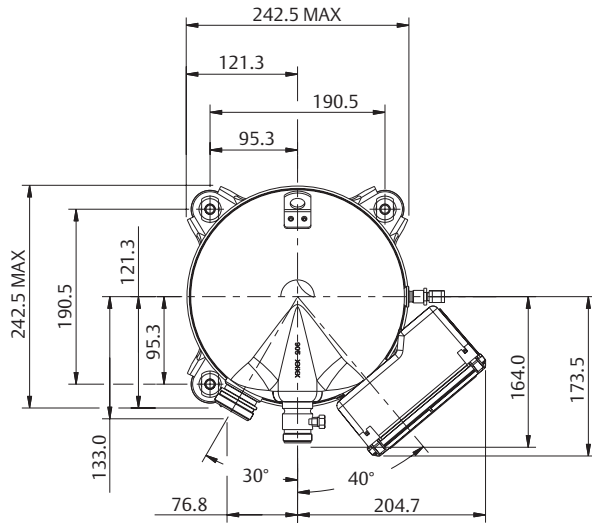

Terminal Box Layout Standard
Scale 3:4

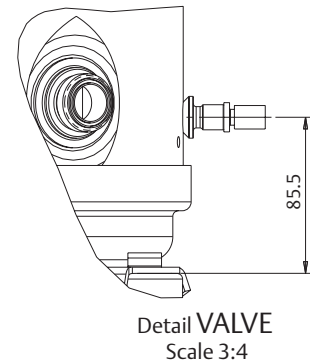
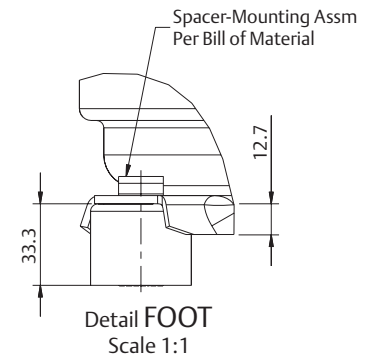
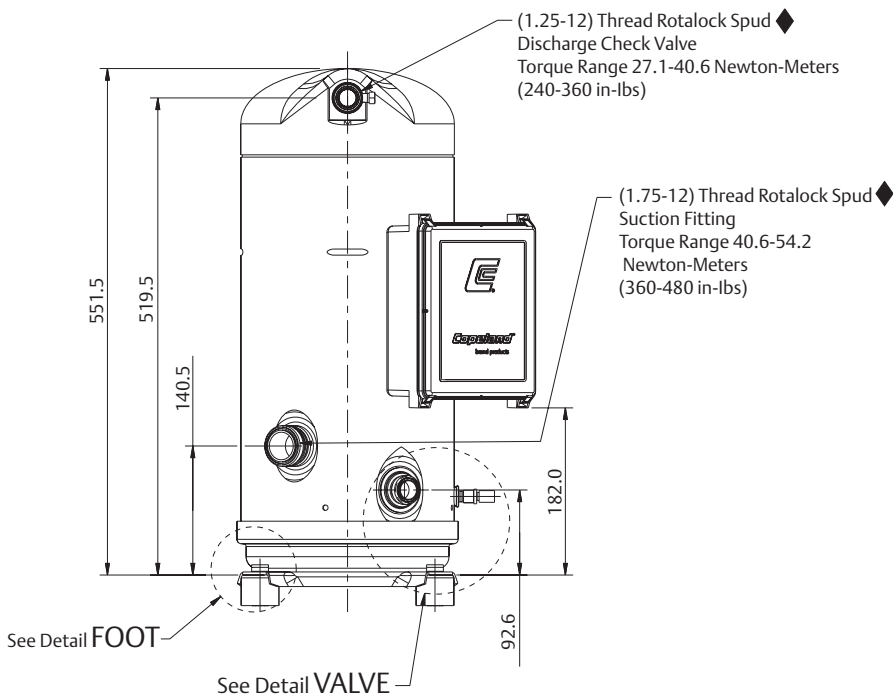

Dimensional drawings

ZB130KQ/KQE

Brazing (BOM 550), Rotalock (BOM 551)

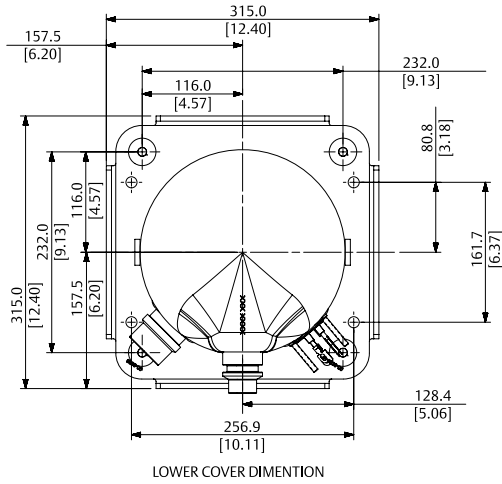

LOWER COVER DIMENTION

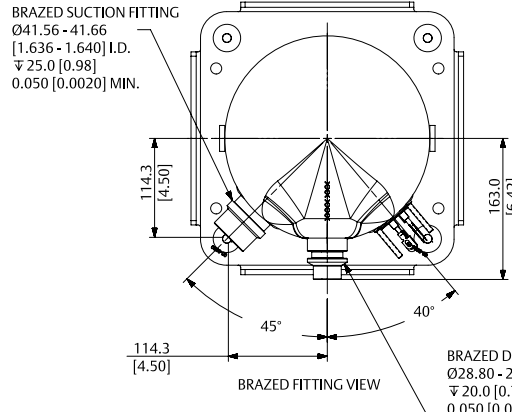

BRAZED SUCTION FITTING
 Ø41.56 - 41.66
 [1.636 - 1.640] I.D.
 ∇ 25.0 [0.98]
 0.050 [0.0020] MIN.

BRAZED DISCHARGE FITTING
 Ø28.80 - 28.90 [1 - 1/8] I.D.
 ∇ 20.0 [0.79]
 0.050 [0.0020] MIN.
 DISCHARGE FITTING

BRAZED FITTING VIEW

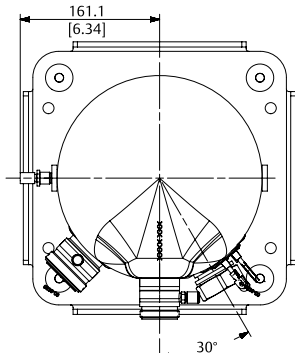

SIGHT GLASS VIEW

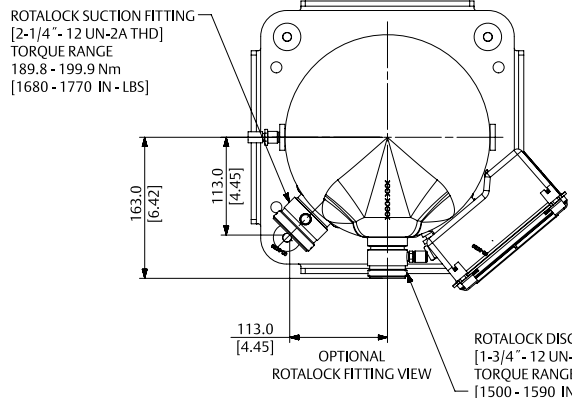

ROTALOCK SUCTION FITTING
 [2-1/4" - 12 UN-2A THD]
 TORQUE RANGE
 189.8 - 199.9 Nm
 [1680 - 1770 IN - LBS]

ROTALOCK DISCHARGE FITTING
 [1-3/4" - 12 UN-2A THD]
 TORQUE RANGE 169.5 - 179.6 Nm
 [1500 - 1590 IN - LBS]

OPTIONAL ROTALOCK FITTING VIEW

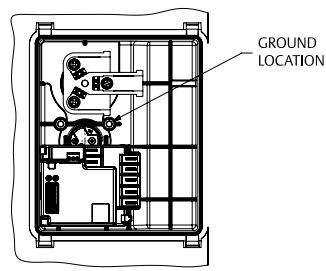
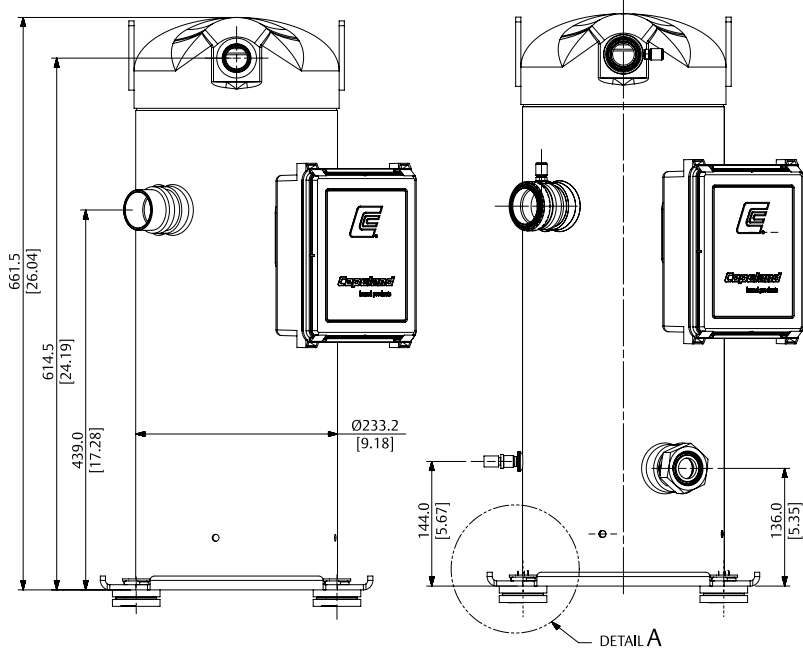

TERMINAL BOX LAYOUT STANDARD
 SCALE 2:3

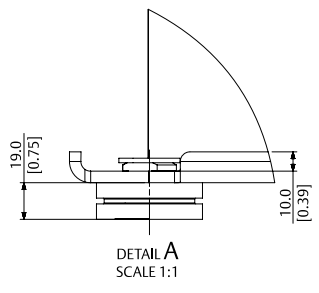

DETAIL A
 SCALE 1:1

Dimensional drawings

ZB150KQ/KQE

Brazing (BOM 522), Rotalock (BOM 523)

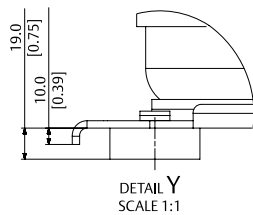
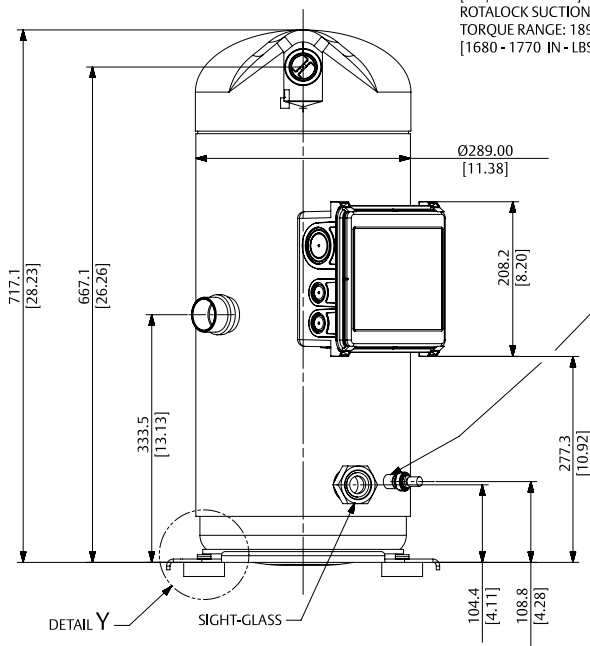
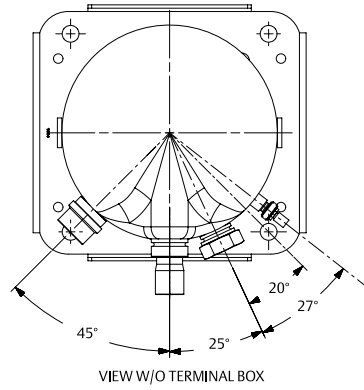
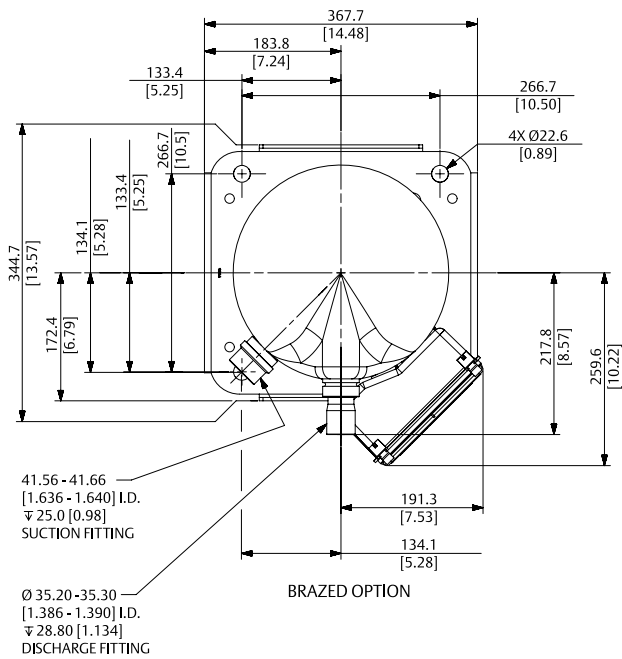

[2-1/4" - 12 UN-2A] THREAD
ROVALOCK SUCTION
TORQUE RANGE: 189.8 - 199.9 Nm
[1680 - 1770 IN - LBS]

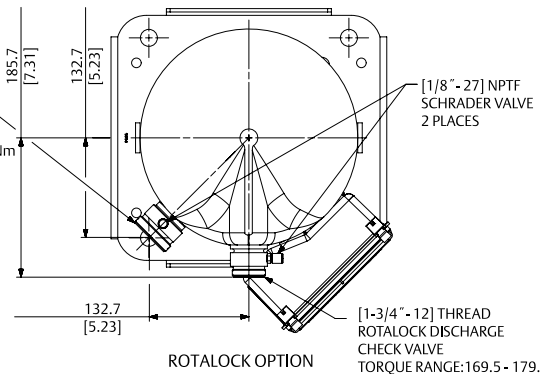

∅ 9.60 - 9.78 [0.378 - 0.385] I.D.
∅ 9.40 [0.37] MIN
M9 x 1.25-6G ∅ 20.0
1-14 UNS-2A

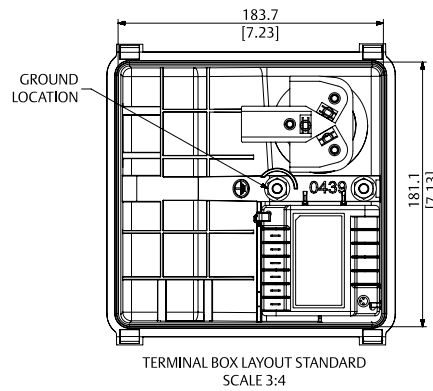

Dimensional drawings

ZB190KQ/KQE, ZB220KQ/KQE

Brazing (BOM 522), Rotalock (BOM 523)

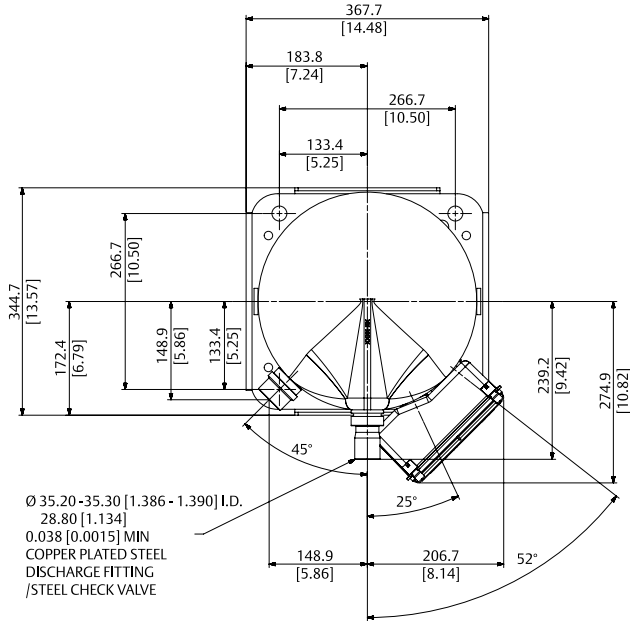

BRAZED OPTION

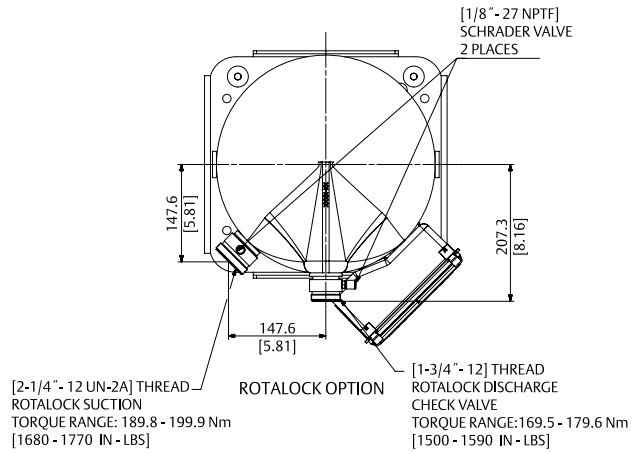

ROTALOCK OPTION

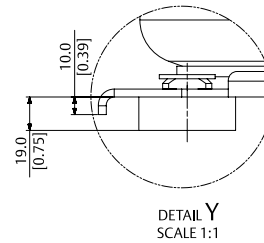
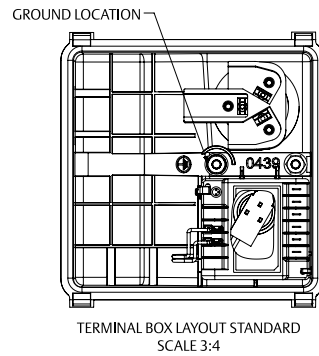
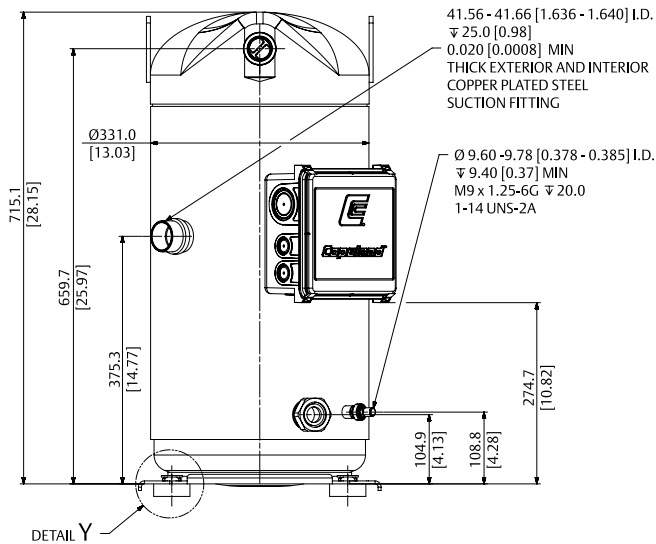

Electrical wiring diagram

ZB15-ZB114

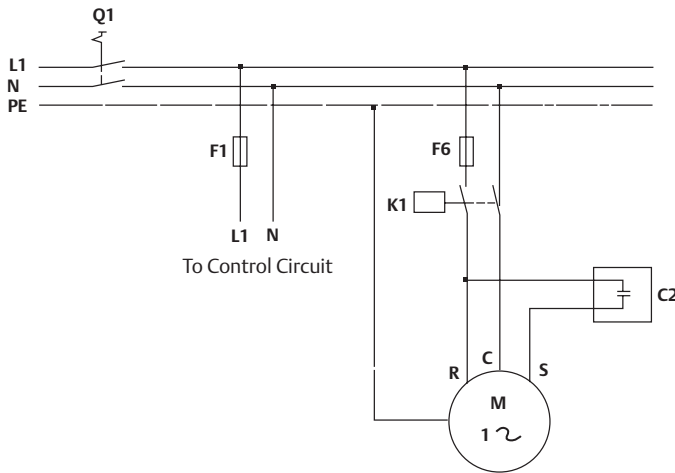

Single phase circuit (ZB15-ZB29)

Electrical schematics

L1/N/PE: Single phase lines (line/neutral/ground)

Q1: Manual switch

F1/F6: Fuse

K1: Compressor contactor

C2: Run capacitor

M: Compressor motor

R/C/S: Compressor terminal

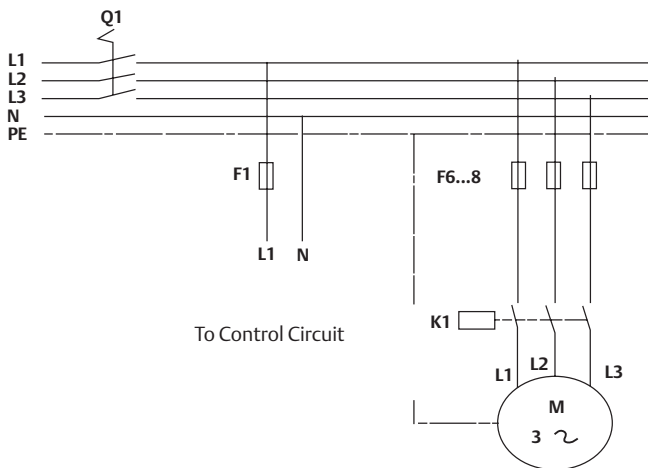

3 Phase (ZB15-ZB114)

(with Motor Protection Code "F")

Electrical Schematics

L1/L2/L3/N/PE: 3 Phase Lines (line/neutral/ground)

Q1: Manual Switch

F1/F6..8: Fuse

K1: Compressor Contactor

M: Compressor Motor

L1/L2/L3: Compressor Terminal

Electrical wiring diagram

ZB130

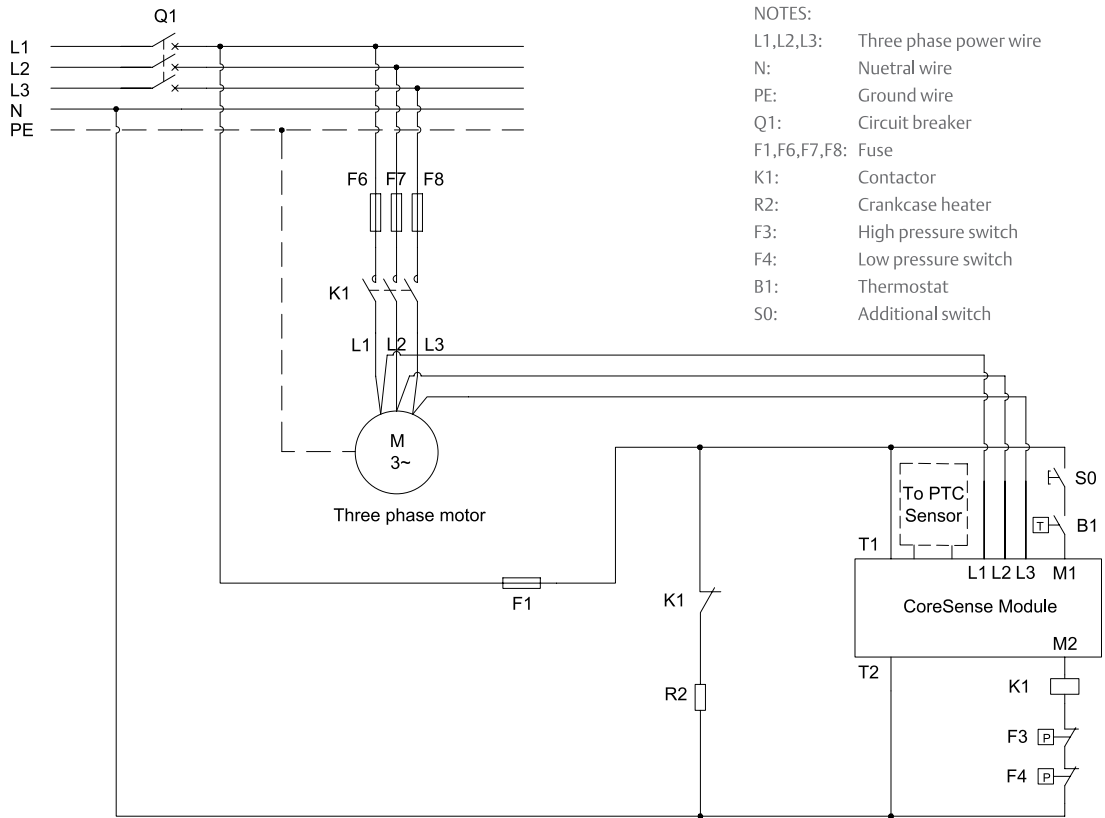

ZB150 - ZB220

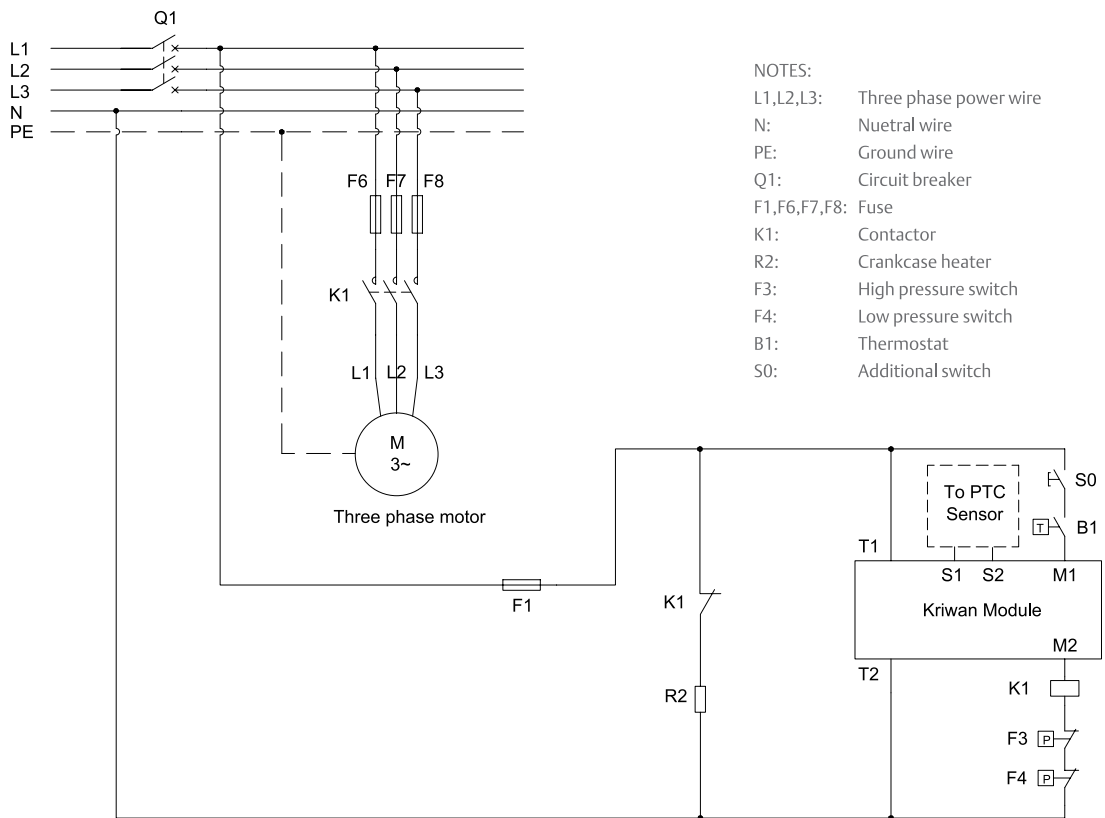

Quick application guide

1. Scroll compression process



Compression in the scroll is created by the interaction of an orbiting spiral and a stationary spiral. Gas enters the outer openings as one of the spirals orbits.



By the time the gas arrives at the center port, discharge pressure has been reached.

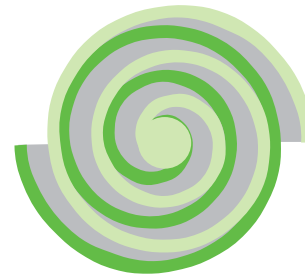

Actually, during operation, all six gas passages are in various stages of compression at all times, resulting in nearly continuous suction and discharge.



The open passages are sealed off as gas is drawn into the spiral.



As the spiral continues to orbit, the gas is compressed into two increasingly smaller pockets.

The scroll is a simple compression concept first patented in 1905. A scroll is an involute spiral which, when matched with a mating scroll form as shown above, generates a series of crescent-shaped gas pockets between the two members. During compression, one scroll remains stationary (fixed scroll) while the other form (orbiting scroll) is allowed to orbit (but not rotate) around the first form. As this motion occurs, the pockets between the two forms are slowly pushed to the center of the two scrolls while simultaneously being reduced in volume. When the pocket reaches the center of the scroll form, the gas, which is now at a high pressure, is discharged out of a port located at the center. During compression, several pockets are being compressed simultaneously, resulting in a very smooth process. Both the suction process (outer portion of the scroll members) and the discharge process (inner portion) are continuous.

2. Compressor internal protections

2.1 Internal pressure relief (IPR) Valve

There is an internal pressure relief valve on all ZB15~ZB48 refrigeration scroll compressors which opens at a differential pressure of 28 bar \pm 3 bar between high and low-pressure sides. A high-pressure cut-out is still required due to the capabilities of pumping to high pressures once the discharge is obstructed. The IPR valve is a safety device, not an HP switch. It is not designed for repeated operation and there is no guarantee that it will reset correctly if it does have repeated operation.

ZB58~ZB114, ZB130~ZB220 Copeland Scroll compressors do not have internal pressure relief (IPR) valves. To avoid abnormally high operating pressures, a high pressure control must be used in all applications.

If any type of discharge line shut-off valve is used, the high pressure control must be installed between the compressor discharge fitting and the valve. Compressors with rotalock discharge fittings have a connection on the rotalock fitting for the high pressure cut-out switch connection.

2.2 High pressure control

A high pressure cut-out control must be used in all applications. The high pressure control should have a manual reset feature for the highest level of system protection.

The maximum, recommended low pressure cut-out switch settings are:

Refrigerants	High pressure cut out setting
R22	25.4 bar(g)
R404A	27.4 bar(g)
R134a	22.3 bar(g)
R407F	23.9 bar(g)

2.3 Low pressure control

A low pressure control is highly recommended for loss of charge protection and other system fault conditions that may result in very low evaporating temperatures. Even though these compressors have internal discharge temperature protection, loss of system charge will result in overheating and recycling of the motor overload protector. Prolonged operation in this manner could result in oil pump out and eventual bearing failure.

The low pressure cut-out setting will depend on the application type and minimum expected evaporating temperature. The low pressure cut-out should be selected to prevent compressor overheating and other system failure modes.

The minimum, recommended low pressure cut-out switch settings are:

Refrigerants	Low pressure cut-out setting
R22	2.3 bar(g)
R404A	2.0 bar(g)
R134a	0.6 bar(g)
R407F	1.5 bar(g)

2.4 Discharge temperature protection

Events such as loss of charge, condenser fan failure, or low side charging with inadequate pressure will cause the discharge gas to quickly rise. Excessively high discharge gas temperatures would affect the scroll compressor reliability. To prevent damage to scroll compressors ZB scroll compressors are built-in with internal scroll temperature protection.

Compressor models ZB15~ZB48 incorporate a thermo disc which is a temperature-sensitive snap disc device located at the scroll discharge port or muffler plate. It is designed to open and route hot discharge gas back to the motor protector thus removing the compressor from the line.

ZB58~ZB130 models incorporate ASTP feature (Advanced Scroll Temperature Protection). ASTP feature will cause the scrolls to separate and stop pumping but allow the motor to continue to run. After the compressor runs for some time without pumping gas, the motor protector will open. Depending on the heat build up in the compressor, it may take up to two hours for the motor protector to reset.

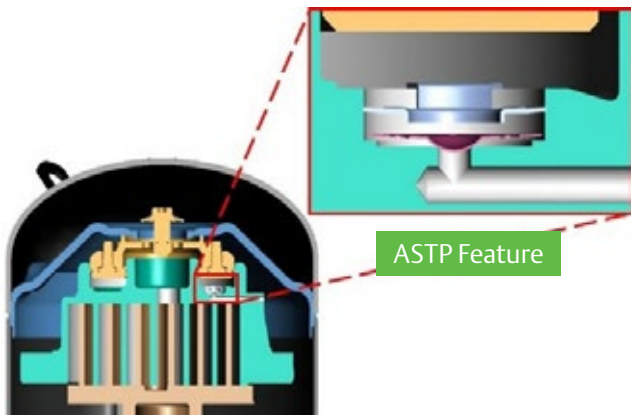

ZB150~ZB220 high discharge temperature protection is provided by a thermistor probe in the discharge plenum of the scroll. Excessive discharge temperature will cause the electronic protector module to trip. The discharge gas thermistor is wired in series with the motor thermistor chain.

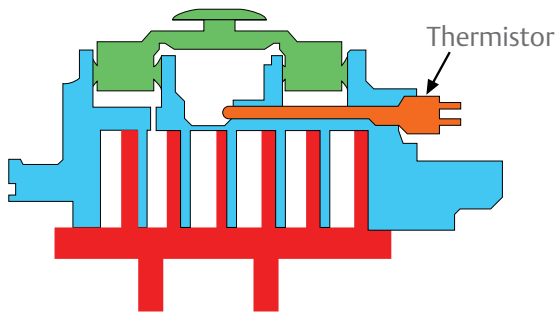

Internal discharge temperature sensor position

2.5 Motor protection

For the models with a motor protection code “F”, an internal line break motor protector is located in the center of the Y of the motor windings. This protector disconnects all three phases in case of an overload or over-temperature condition. The protector reacts to a combination of motor current and motor winding temperature. The internal protector protects against single phasing. Time must be allowed for the motor to cool down before the protector will reset. If current monitoring to the compressor is available, the system controller can take advantage of the compressor internal protector operation. The controller can lock out the compressor if current draw is not coincident with contactor energizing, implying that the compressor has shut off on its internal protector. This will prevent unnecessary compressor cycling on a fault condition until corrective action can be taken.

Models ZB95~ZB114, ZB150~ZB220 with motor protection code “W” and ZB130 with code “E” use a combination of sensors and an electronic module (refer to section 2.6) for motor protection. There are a few PTC (positive temperature coefficient) internal thermistors connected in series that react with avalanche resistance in the event of high temperatures. All PTC are used to sense motor temperature. The thermistor circuit is connected to the protector module terminals. When any thermistor reaches a limiting value, the module interrupts the control circuit and shuts off the compressor. After the thermistor has cooled sufficiently, the resistance will decrease, thus allowing the module to reset. However, the module has a 30-minute time delay before reset after a thermistor trip.

2.6 External protection module

The ZB130 scroll compressor is equipped with a CoreSense module. The module is installed in the compressor electrical box and provides advanced diagnostics, protection and communications that enhance compressor performance and reliability.



The CoreSense Communications Module has the following key features:

1. Motor temperature protection
2. Missing phase protection
3. Reverse phase protection
4. Low control circuit voltage protection
5. Short cycling detection and alert
6. Communication to system controller through RS485/Modbus
7. Storage of operational history, runtime information, and fault counters, etc.
8. Display of status, warning, and alert information via LEDs

CoreSense Communications provides compressor and system protection through its proprietary lockout feature. Depending on the severity and frequency of the fault that caused the trip condition, the CoreSense Communications module can lockout the compressor contactor to prevent damage to the compressor and system components. Less severe fault conditions resulting in an occasional trip will not result in a lockout condition.

Flashing red and green LEDs communicate **Status**, **Warning**, and **Alert** codes to the service technician and the master controller.

Emerson scroll compressors equipped with CoreSense Communications will have an “E” in the electrical code. An example, ZB130KQE-TED.

CoreSense communications module specifications

Module part number	571-0064-06
T1-T2 Power supply & frequency	120-240 VAC, 60 Hz
	115-230 VAC, 50 Hz
Allowable voltage range	85-265 VAC
T2/T1 Low voltage trip	85/170 VAC
T2/T1 Low voltage reset	95/185 VAC
Power consumption	5 VA
M1-M2 Contact rating	2.5A Max
Motor temperature trip resistance	> 4.5KΩ ± 25%
Open motor thermistor trip resistance	>220KΩ
Shorted motor thermistor trip resistance	<40Ω
Motor temperature reset resistance	< 2.75KΩ
Reset time after trip	30 minutes
Ambient temperature range	-40° to 65°C

An explanation of the terminal designations follows:

- **T2-T1:** Module power supply, 120-240 VAC 60 Hz, 115-230 VAC, 50 Hz
- **L1-L2-L3:** Phase inputs corresponding to compressor input power L1-L2-L3.
- **M2-M1:** Normally open control circuit contacts; M2- M1 should be wired in series with the compressor contactor.
- **A (-), GND, B (+):** RS485 communications.
- **Temperature Plug:** the PTC and common connections.

DIP Switch Configuration of ZB130: DIP switch selection for the Modbus address, baud rate, parity, and other operating conditions simplify service and start-up procedures. The following table lists the purpose of each switch.

DIP Switch purpose

DIP Switch Number	On	Off
1 through 5	120-240 VAC, 60 Hz	
6	Baud rate = 9600	Baud rate = 19200
7	Even parity	No parity
8	Network mode	Stand alone
9 ₁		PTC
10	Enable short cycle protection	Disable short cycle protection

1 Thermistor configuration: = PTC only (2 wire connectors)

The module must be reset after changing any of the DIP switch settings for changes to take effect.

CoreSense Communications modules are shipped from the factory with the DIP switches set to default settings for standalone operation. Switch 1 is turned “on” as part of a quality control check to verify communications capability of the module before it leaves the compressor manufacturing plant. All other DIP switch default settings are in the “off” position.

If DIP switch settings are inadvertently changed, the compressor will operate, but could have some loss of protection. Scroll temperature protection and short cycle protection could be disabled.

Dip-switch Default factory setting

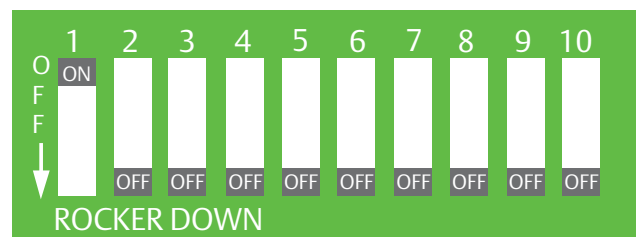

ZB150-ZB220 scroll compressor equipped with a Kriwan protection module. The electronic motor protection system used in all TW* motor code. This system utilizes the temperature-dependent resistance of the thermistors (also called PTC-resistance) to read the winding temperature. A chain of four thermistors connected in series is embedded in the motor windings so that the temperature of the thermistors can follow the winding temperature with little inertia. An electronic module INT69SCY2 is required to process the resistance values and trip a control depending on the thermistor resistance



Kriwan protection module specifications

Module part number	071-0684-00
Type	Kriwan diagnose INT69 SC2
Protection	Motor & scroll temperature protection
T1- T2 Power supply & frequency	120-240 VAC, 60 Hz
	115-230 VAC, 50 Hz
Power consumption	3 VA
M1-M2 Contact rating	2.5A Max
Trip resistance	>4.5KΩ
Reset resistance	<2.75KΩ
Reset time after trip	30 minutes
Ambient temperature range	-30°C to +70°C
Motor temperature reset resistance	< 2.75KΩ
Reset time after trip	30 minutes
Ambient temperature range	-40° to 65°C

An explanation of the terminal designations follows:

- T2-T1: Module power supply, 120-240 VAC 60 Hz, 115-230 VAC, 50 HZ
- S2-S1: Connect to motor and scroll PTC sensors
- M2-M1: Normally open control circuit contacts; M2- M1 should be wired in series with the compressor contactor.

3. Compressor information

3.1 Fusite (Terminal)

Fusite (Terminal) pin orientation for single-phase and three phase refrigeration scroll compressors are shown in below and inside the terminal box.

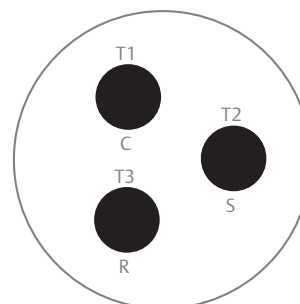

Motor Terminal (Fusite) Connections for Single Phase and Three Phase Scrolls

3.2 Three-phase rotation direction

Scroll compressors are directional dependent: i.e., they will compress in one rotational direction only. On single-phase compressors, this is not an issue since they will only start and run in the proper direction. Three-phase scrolls, however, will rotate in either direction depending on the power of the phasing. So there is a 50/50 chance of connected power being “backwards.” Contractors should be warned of this. Appropriate instructions or notices should be provided by the Original Equipment Manufacturer.

Verification of proper rotation can be made by observing that the suction pressure drops and the discharge pressure rises when the compressor is energized. Additionally, if operated in reverse the compressor is noisier and its current draw is substantially reduced compared to tabulated values.

Although operation of scroll in reverse direction for brief periods of time is not harmful, continued operation could result in failure.

All three-phase compressors are wired identically internally. Once the correct phasing is determined for a specific system or installation, connecting properly phased power leads to the same fusite terminals will maintain the proper rotation.

3.3 Brief power interruptions

Brief power interruptions (less than 0.5 second) may result in powered reverse rotation of single-phase refrigeration scroll compressors. High-pressure discharge gas expands backward through the scrolls at power interruption causing the scroll to orbit in the reverse direction. If power is reapplied while this reversal is occurring, the compressor may continue to run noisily in the reverse direction for several minutes until the compressor internal protector trips. This has no negative effect on durability. When the protector resets, the compressor will start and run normally.

Emerson strongly encourages the use of a timer which can sense brief power interruptions and lock the compressor out of operation for two minutes. No time delay is required on three phase models to prevent reverse rotation due to power interruptions.

3.4 Oil types

In HCFC R22 applications, mineral oil is used in the compressor. Polyol ester lubricants must be used with HFC refrigerants (R404A, R507, R134a, R407F, R448A and R449A). Compressors using polyol ester oil are identified with an “E” in the model number. A separate form may be requested (Form 93-11) which lists Emerson approved lubricants that may be used to recharge these compressors or if the addition of oil is required. See compressor nameplate for original oil charge. A complete recharge should be four ounces (118ml) less than the original oil charge. If the oil level is above the sight glass, it may lead to oil circulation rates higher than 1.5% which may lead to decreased capacity as the oil coats the evaporator coils.

3.5 Deep vacuum operation

WARNING: Do not run a refrigeration scroll compressor in a vacuum. Failure to heed this advice can result in permanent damage to the compressor.

A low-pressure control is required for protection against vacuum operation. See the section 2.3 on pressure controls for the proper set points.

Scrolls compressors (as with any refrigeration compressor) should never be used to evacuate refrigeration or air conditioning systems.

The scroll compressor can be used to pump-down refrigerant in a unit as long as the pressures remain within the operating envelope. Low suction pressures will result in overheating of the scrolls and permanent damage to the compressor drive bearing or cause the scroll temperature protection to activate.

3.6 Shell temperature

Certain types of system failures, such as condenser or evaporator fan blockage or loss of charge, may cause the top shell and discharge line to briefly but repeatedly reach temperatures above 350°F (177°C) as the compressor cycles on its internal protection devices. Care must be taken to ensure that wiring or other materials, which could be damaged by these temperatures, do not come in contact with these potentially hot areas.

3.7 Suction and discharge fittings

Scroll compressors are available with stub tube or rotalock connections. The stub tube version has copper plated steel suction and discharge fittings. These fittings are far more rugged than copper fittings used on other compressors. Due to the different thermal properties of steel and copper, brazing procedures may have to be changed from those commonly used. Assembly and brazing procedures are explained in the later part of application guide.

3.7 Suction and discharge fittings

Scroll compressors are available with stub tube or rotalock connections. The stub tube version has copper plated steel suction and discharge fittings. These fittings are far more rugged than copper fittings used on other compressors. Due to the different thermal properties of steel and copper, brazing procedures may have to be changed from those commonly used. Assembly and brazing procedures are explained in the later part of application guide.

3.8 Starting characteristics of single-phase compressors

Single-phase scroll compressors are designed with PSC type motors and therefore will start without the need of start assist devices in most applications. However, if low voltage conditions exist at start up, protector trips can result. Therefore, start assist devices (start capacitors and relays) are available to maximize starting characteristics under abnormal conditions.

3.9 Special handling consideration for ZB58-ZB114

ZB58- ZB114 model compressors have the suction fitting located low on the shell. Due to this, it's recommended to leave the suction connection plug in place until the compressor is set into the unit. The discharge connection plug should be removed first before pulling the suction connection plug to allow the dry air pressure inside the compressor to escape. Pulling the plugs in this sequence prevents oil mist from coating the suction tube making the brazing difficult. The copper coated steel suction tube should be cleaned before brazing. No object (example a swaging tool) should be inserted deeper than 50mm into the suction tube or it might damage the suction screen and motor.

3.10 Electrical information

Locked rotor current (LRA)

LRA is the higher average current as measured on a mechanically blocked compressor tested under nominal voltage. LRA is printed on the nameplate.

The LRA value can be used as a rough estimation for the starting current. However in most cases, the real starting current will be lower. Many countries have defined limits for the starting current in domestic use. A soft starter can be applied to reduce starting current.

Maximum continuous current (MCC)

The MCC is the current at which the internal motor protection trips under maximum load and low voltage conditions.

This MCC valve is the maximum at which the compressor can be operated in transient conditions and out of the application envelope. Above this valve the overload will switch off to protect the motor.

Maximum operating current (MOC)

The maximum operating current is the current when the compressor operates at maximum load conditions and 10% below nominal voltage. This valve, which is the maximum rated load current for the compressor. MOC is printed on the nameplate.

The MOC can be used to select cables and contactors. In normal operation, the compressor current consumption is always less than the MOC valve.

4. System protection guidelines

4.1 Accumulator requirement

Due to the scrolls' inherent ability to handle liquid refrigerant in flooded start and defrost cycle operation conditions, accumulators may not be required. An accumulator is required on single compressor systems when the charge limitations exceed those values listed in the table. On systems with defrost schemes or transient operations that allow prolonged uncontrolled liquid return to the compressor, an accumulator is required.

Excessive liquid flood back or repeated flooded starts will dilute the oil in the compressor causing inadequate lubrication and bearing wear. Proper system design will minimize liquid flood back, thereby ensuring maximum compressor life.

Models	Refrigerant charge limits
ZB15-ZB29	3.6 Kg
ZB38-ZB48	4.5 Kg
ZB58-ZB114	7.5 Kg
ZB150-ZB220	11.3 Kg

4.2 Crankcase heaters requirement

A crankcase heater is used to prevent refrigerant migrating into the shell during standstill periods. Crankcase heaters are required on three phase compressors when the system charge exceeds the charge limits. This requirement is independent of system type and configuration. The crankcase heater must be turned on a minimum of 12 hours prior to starting the compressor and must remain energized during compressor off cycles.

The heater should be installed as close as possible to the bottom of the compressor but should avoid weld points that could cause poor thermal contact. The clamp should straddle the vertical seam weld of the compressor shell to avoid a hot spot on the heater element. It is important that the clamp screw is torqued to the range of 2.3-2.8 N-m (20-25 in-lb) to ensure adequate contact and to prevent heater burnout. Never apply power to the heater in free air or before the heater is installed on the compressor to prevent overheating and burnout.

Crankcase Heater Location – ensure that clamp is over the vertical weld sea



4.3 Pump-down cycle

A pump-down cycle for control of refrigerant migration may be used instead of, or in conjunction with, a crankcase heater when the compressor is located so that cold air blowing over the compressor makes the crankcase heater ineffective. A separate external check valve must be added to the discharge line if pump-down is used. The built-in scroll discharge check valve is designed to stop extended reverse rotation and prevent high pressure gas from leaking rapidly into the low side after shut off. High side leak-back through the check valve may exceed amounts typically found in reciprocating compressors with reed valves. This can cause the compressor to recycle more frequently. Repeated short-cycling of this nature can result in low compressor oil and consequent damage to the compressor. The recommended external check valve will prevent the frequent recycling due to leak-back. The low pressure control cut-in and cut-out settings have to be reviewed since a relatively large volume of gas will re-expand from the high side of the compressor into the low side on shut down. Emerson recommends that the cut out setting of the pump-down pressure control be set no more than a few degrees of equivalent saturated pressure below the lowest expected normal operating pressure. It is not necessary to pump-down into nearly a vacuum to remove all liquid refrigerant for the low side. To achieve a fairly wide control differential the cut in setting should be set a few degrees of equivalent saturated pressure below the lowest expected temperature of the medium that is cooled. Copeland Scroll compressors trap a considerable volume of high pressure gas between the muffler plate and the top cap. When the compressor shuts down the trapped gas will expand back into the suction side of the system. This frequently causes a pulse of pressure to propagate down the suction line and can cause the low pressure switch to reset. The compressor must not be allowed to short cycle which may result in oil pump out. The electrical circuitry should be arranged

so that compressor restart is triggered by demand from the thermostat rather than a reset low pressure switch. Setting a wider differential between the cutout and cut in pressures of a low pressure switch may solve the short cycling problem but may also result in unacceptable temperature swings in the cooled space. If short cycling cannot be avoided, using a 3 minute time delay will limit the cycling of the compressor to an acceptable level.

4.4 Filter screens in system

The use of screens finer than 30 x 30 mesh (0.6 mm openings) anywhere in the system is not recommended. Field experience has shown that finer mesh screens used to protect thermal expansion valves, capillary tubes, or accumulators can become temporarily or permanently plugged with normal system debris and block the flow of either oil or refrigerant to the compressor. Such blockage can result in compressor failure.

5. Testing guidelines

5.1 Compressor hi-pot testing

Refrigeration scroll compressors are configured with the motor in the bottom of the shell. Unlike most other hermetic compressors, the motor of a scroll compressor can be immersed in refrigerant when liquid is present in the shell. Hi- Pot tests with liquid refrigerant in the shell can show higher levels of current leakage due to the higher electrical conductivity of liquid refrigerant vs. refrigerant vapor and oil. This phenomenon can occur with any compressor when the motor is immersed in refrigerant and does not present any safety issue. To lower the current leakage reading, operate the system for a brief period of time redistributing the refrigerant to a more normal configuration and test again. Under no circumstances should the Hipot test be performed while the compressor is in vacuum.

5.2 Scroll compressor functional check

A functional compressor test with the suction service valve closed to check how low the compressor will pull suction pressure is not a good indication of how well a compressor is performing. Such a test will almost certainly damage a scroll compressor. The following diagnostic procedure should be used to evaluate whether a Copeland Scroll compressor is working properly.

1. Proper voltage to the unit should be verified.
2. The normal checks of motor winding continuity and short to ground should be made to determine if the inherent overload motor protector has opened or if an internal motor short or ground fault has developed. If the protector has opened, the compressor must be allowed to cool sufficiently to allow it to reset.
3. Proper indoor and outdoor blower/fan operation should be verified.
4. With service gauges connected to suction and discharge pressure fittings, turn on the compressor. If suction pressure falls below normal levels, the system is either low on charge or there is a flow blockage in the system.
5. In single phase compressors, if suction pressure does not drop and discharge pressure does not rise to normal levels the compressor is faulty. But in three phase compressors, reverse any two of the compressor power leads and reapply power to make sure compressor was not wired to run in reverse direction.
6. Before replacing, be certain that the compressor is actually defective. As a minimum, recheck a compressor returned from the field in the shop or depot for Hi-pot, winding resistance, and ability to start. Experience shows that more than one third of compressors are determined to have nothing found wrong. They were mis-diagnosed in the field as being defective. Replacing working compressors unnecessarily costs everyone.
7. NEVER test a scroll compressor by closing the suction valve or the liquid feed to the evaporator and pumping the compressor into a vacuum.

6. Field & installation guidelines

6.1 Assembly line and field brazing

ZB Scroll compressors are available with stub tube and rotalock connections. The stub tube version has copper plated steel suction and discharge fittings. Due to the different thermal properties of steel and copper, brazing procedures may have to be changed from those commonly used. The guidelines below give a description for assembly line and field brazing procedures.

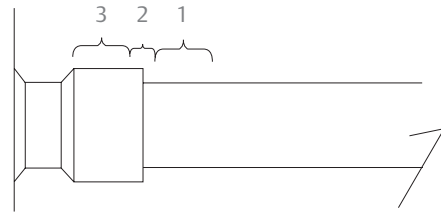

New installations

The copper-coated steel suction and discharge tubes on scroll compressors can be brazed in approximately the same manner as any copper tube.

- Recommended brazing materials: Any silfos material is recommended, preferably with a minimum of 5% silver. However, 0% silver is acceptable.
- Be sure compressor tube fittings I.D. and connecting tube O.D. are clean prior to assembly. If oil film is present wipe with denatured alcohol, Dichloro-Trifluoroethane or other suitable solvent.
- Using a double-tipped torch apply heat in Area 1. As tube approaches brazing temperature, move torch flame to Area 2.
- Heat Area 2 until braze temperature is attained, moving torch up and down and rotating around tube as necessary to heat tube evenly. Add braze material to the joint while moving torch around joint to flow braze material around circumference.
- After braze material flows around joint, move torch to heat Area 3. This will draw the braze material down into the joint. The time spent heating Area 3 should be minimal.
- As with any brazed joint, overheating may be detrimental to the final result.

6.2 Field service

Unbrazing system components

CAUTION! If the refrigerant charge is removed from a scroll unit by bleeding the high side only, it is sometimes possible for the scrolls to seal preventing pressure equalization through the compressor. This may leave the low side shell and suction line tubing pressurized. If a brazing torch is then applied to the low side, the pressurized refrigerant oil mixture could ignite as it escapes and contacts the brazing flame. It is important to check both the high and low sides with manifold gauges before unbrazing. In the case of an assembly line repair, remove the refrigerant from both the high and low sides.

Instructions should be provided in appropriate product literatures and assembly areas.

- To disconnect: Reclaim refrigerant from both the high and low side of the system. Cut tubing near compressor.
- To reconnect. Recommended brazing material is Silfos with minimum 5% silver or silver braze material with flux. Insert tubing stubs into fitting and connect to the system with tubing connectors. Follow Installation brazing instructions.

Brazing procedure

Section 6.1 discusses the proper procedures for brazing the suction and discharge lines to a Copeland Scroll compressor. It is important to flow nitrogen through the system while brazing all joints during the system assembly process. Nitrogen displaces the air and prevents the formation of copper oxides in the system.

If allowed to form, the copper oxide flakes can later be swept through the system and block screens such as those protecting capillary tubes, thermal expansion valves, and accumulator oil return holes. The blockage - whether it is of oil or refrigerant - is capable of doing damage resulting in compressor failure.

6.3 Compressor replacement after motor burn

In the case of a motor burn, the majority of contaminated oil will be removed with the compressor. The rest of the oil is cleaned through use of suction and liquid line filter dryers. A 100% activated alumina suction filter drier is recommended but must be removed after 72 hours. Separate bulletins are available on request for clean-up procedures and for liquid line filter drier recommendations. AE Bulletin 24-1105 for clean-up procedures and AE Bulletin 11-1297 for liquid line filter drier recommendations.

It is highly recommended that the suction accumulator be replaced if the system contains one. This is because the accumulator oil return orifice or screen may be plugged with debris or may become plugged shortly after a compressor failure. This will result in starvation of oil to the replacement compressor and a second failure.

6.4 System charging procedure

Systems should be charged with liquid on the high side to the extent possible. The majority of the charge should be pumped into the high side of the system to prevent hi pot failures, and bearing washout during first time start. If additional charge is needed, it should be added as liquid, in a controlled manner, to the low side of the system with the compressor operating. Pre-charging on the high side and adding liquid on the low side of the system are both meant to protect the compressor from operating with abnormally low suction pressures during charging.

Do not start the compressor while the system is in a deep vacuum. Internal arcing may occur when a compressor is started in a vacuum. Do not operate compressor without enough system charge to maintain at least 7 psig (0.5Kg/cm²) suction pressure. Do not operate with a restricted suction. Do not operate with the low pressure cut-out jumpered. Allowing pressure to drop below 2°F (-16°C) for more than a few seconds may overheat scrolls and cause early drive bearing damage or cause the scroll temperature protection to activate. Do not use compressor to test opening set point of high pressure cutout. Bearings are susceptible to high load damage before they have had several hours of normal running for proper break in. Never install a system in the field and leave it unattended with no charge, or with the service valves closed without securely locking out the system. This will prevent unauthorized personnel from accidentally operating the system and potentially ruining the compressor by operating with no refrigerant flow.

Available models list

Motor	ZB Refrigeration scroll models			
	Rotalock	Stub tube	Manufacturing plant	Status
PFJ 220-240V-1ph-50 Hz; 265v-1ph-60 Hz	ZB15KQ/E-PFJ-559	ZB15KQ/E-PFJ-558	Thailand/Suzhou	Active
	ZB19KQ/E-PFJ-559	ZB19KQ/E-PFJ-558	Thailand/Suzhou	Active
	ZB21KQ/E-PFJ-559	ZB21KQ/E-PFJ-558	Thailand/Suzhou	Active
	ZB26KQ/E-PFJ-559	ZB26KQ/E-PFJ-558	Thailand/Suzhou	Active
	ZB29KQ/E-PFJ-559	ZB29KQ/E-PFJ-558	Thailand/Suzhou	Active
PFV 200v-1ph-50 Hz; 208-230V-1ph-60 Hz	ZB15KQ/E-PFV-559	ZB15KQ/E-PFV-558	Thailand/Suzhou	Active
	ZB19KQ/E-PFV-559	ZB19KQ/E-PFV-558	Thailand/Suzhou	Active
	ZB21KQ/E-PFV-559	ZB21KQ/E-PFV-558	Thailand/Suzhou	Active
	ZB26KQ/E-PFV-559	ZB26KQ/E-PFV-558	Thailand/Suzhou	Active
	ZB29KQ/E-PFV-559	ZB29KQ/E-PFV-558	Thailand/Suzhou	Active
	ZB38KQ/E-PFV-559	ZB38KQ/E-PFV-558	Thailand	Active
TFD/TWD 380-420V-3ph-50 Hz; 460V-3ph-60 Hz	ZB15KQ/E-TFD-559	ZB15KQ/E-TFD-558	Thailand/Suzhou	Active
	ZB19KQ/E-TFD-559	ZB19KQ/E-TFD-558	Thailand/Suzhou	Active
	ZB21KQ/E-TFD-559	ZB21KQ/E-TFD-558	Thailand/Suzhou	Active
	ZB26KQ/E-TFD-559	ZB26KQ/E-TFD-558	Thailand/Suzhou	Active
	ZB29KQ/E-TFD-559	ZB29KQ/E-TFD-558	Thailand/Suzhou	Active
	ZB38KQ/E-TFD-559	ZB38KQ/E-TFD-558	Thailand/Suzhou	Active
	ZB45KQ/E-TFD-559	ZB45KQ/E-TFD-558	Thailand/Suzhou	Active
	ZB48KQ/E-TFD-559	ZB48KQ/E-TFD-558	Thailand/Suzhou	Active
	ZB58KQ/E-TFD-551	ZB58KQ/E-TFD-550	Thailand/Suzhou	Active
	ZB66KQ/E-TFD-551	ZB66KQ/E-TFD-550	Thailand/Suzhou	Active
	ZB76KQ/E-TFD-551	ZB76KQ/E-TFD-550	Thailand/Suzhou	Active
	ZB88KQ-TFD-551	ZB88KQ-TFD-550	Thailand/Suzhou	Active
	ZB95KQ/E-TFD-551	ZB95KQ/E-TFD-550	Thailand/Suzhou	Active
	ZB114KQ/E-TFD-551	ZB114KQ/E-TFD-550	Thailand/Suzhou	Active
	ZB114KQ/E-TWD-551	ZB114KQ/E-TWD-550	Thailand	Active
	ZB130KQ/E-TED-551	ZB130KQ/E-TED-550	Suzhou	Active
	ZB150KQ/E-TWD-523	ZB150KQ/E-TWD-522	Suzhou	Active
	ZB190KQ/E-TWD-523	ZB190KQ/E-TWD-522	Suzhou	Active
ZB220KQ/E-TWD-523	ZB220KQ/E-TWD-522	Suzhou	Active	

Motor	ZB Refrigeration scroll models			
	Rotalock	Stub tube	Manufacturing plant	Status
TF7/TW7 380V-3ph-60 Hz	ZB15KQ/E-TF7-559	ZB15KQ/E-TF7-558	Thailand	Active
	ZB19KQ/E-TF7-559	ZB19KQ/E-TF7-558	Thailand	Active
	ZB21KQ/E-TF7-559	ZB21KQ/E-TF7-558	Thailand	Active
	ZB26KQ/E-TF7-559	ZB26KQ/E-TF7-558	Thailand	Active
	ZB29KQ/E-TF7-559	ZB29KQ/E-TF7-558	Thailand	Active
	ZB38KQ/E-TF7-559	ZB38KQ/E-TF7-558	Thailand	Active
	ZB45KQ/E-TF7-559	ZB45KQ/E-TF7-558	Thailand	Active
	ZB48KQ/E-TF7-559	ZB48KQ/E-TF7-558	Thailand	Active
	ZB58KQ/E-TF7-551	ZB58KQ/E-TF7-550	Thailand	Active
	ZB66KQ/E-TF7-551	ZB66KQ/E-TF7-550	Thailand	Active
	ZB76KQ/E-TF7-551	ZB76KQ/E-TF7-550	Thailand	Active
	ZB88KQ-TF7-551	ZB88KQ-TF7-550	Thailand	Active
	ZB95KQ/E-TF7-551	ZB95KQ/E-TF7-550	Thailand	Active
	ZB95KQ/E-TW7-551	ZB95KQ/E-TW7-550	Thailand	Active
	ZB114KQ/E-TW7-551	ZB114KQ/E-TW7-550	Thailand	Active
	ZB130KQ/E-TE7-551	ZB130KQ/E-TE7-550	Suzhou	Active
	ZB150KQ/E-TW7-523	ZB150KQ/E-TW7-522	Suzhou	Active
	ZB190KQ/E-TW7-523	ZB190KQ/E-TW7-522	Suzhou	Active
	ZB220KQ/E-TW7-523	ZB220KQ/E-TW7-522	Suzhou	Active
TF5/TW5 200-220V-3ph-50 Hz; 200-230V-3ph-60 Hz TWC 200V-3ph-50 Hz; 208-230V-3ph-60 Hz	ZB15KQ/E-TF5-559	ZB15KQ/E-TF5-558	Thailand	Active
	ZB19KQ/E-TF5-559	ZB19KQ/E-TF5-558	Thailand/Suzhou	Active
	ZB21KQ/E-TF5-559	ZB21KQ/E-TF5-558	Thailand/Suzhou	Active
	ZB26KQ/E-TF5-559	ZB26KQ/E-TF5-558	Thailand/Suzhou	Active
	ZB29KQ/E-TF5-559	ZB29KQ/E-TF5-558	Thailand/Suzhou	Active
	ZB38KQ/E-TF5-559	ZB38KQ/E-TF5-558	Thailand/Suzhou	Active
	ZB45KQ/E-TF5-559	ZB45KQ/E-TF5-558	Thailand	Active
	ZB48KQ/E-TF5-559	ZB48KQ/E-TF5-558	Thailand	Active
	ZB58KQ/E-TF5-551	ZB58KQ/E-TF5-550	Thailand	Active
	ZB66KQ/E-TF5-551	ZB66KQ/E-TF5-550	Thailand	Active
	ZB76KQ/E-TF5-551	ZB76KQ/E-TF5-550	Thailand	Active
	ZB95KQ/E-TW5-551	ZB95KQ/E-TW5-550	Thailand	Active
	ZB114KQ/E-TW5-551	ZB114KQ/E-TW5-550	Thailand	Active
	ZB130KQ/E-TEC-551	ZB130KQ/E-TEC-550	Suzhou	On hold
	ZB150KQ/E-TWC-523	ZB150KQ/E-TWC-522	Suzhou	On hold
	ZB190KQ/E-TWC-523	ZB190KQ/E-TWC-522	Suzhou	On hold
	ZB220KQ/E-TWC-523	ZB220KQ/E-TWC-522	Suzhou	On hold

KQ: Mineral oil
KQE: POE

Contact lists

Asia Pacific Headquarters

Suite No. 2503-10A, 25/F,
Exchange Tower, 33 Wang Chiu Road,
Kowloon Bay, Kowloon, Hong Kong
Tel: (852) 2866 3108
Fax: (852) 2520 6227

Australia

356 Chisholm Road
Auburn NSW 2144, Australia
Tel: (612) 9795 2800
Fax: (612) 9738 1699

China - Beijing

Room 1203-1205,
North Wing Junefield Plaza Central Tower,
No. 10 Xuan Wu Men Wai Street,
XiCheng District, Beijing, PRC
Tel: (8610) 5095 2188

China - Guangzhou

Guangzhou Office
Unit 2202B, 22/F, Leatop Plaza,
32 Zhujiang East Road, Tianhe Dist.,
Guangzhou 510623, PRC
Tel: (8620) 8595 5188

China - Shanghai

Shanghai Sales Office
7F, Emerson Building, 1582 Gumei
Rd, Shanghai, PRC
Tel: (8621) 3338 7333

India - Mumbai

Delphi B-Wing, 601-602, 6th Floor
Central Avenue,
Hiranandani Business Park,
Powai, Mumbai 400076, India
Tel: (9122) 6786 0793
Fax: (9122) 6662 0500

India - Pune

Plot No. 23, Rajiv Gandhi Infotech Park,
Phase - II, Hinjewadi,
Pune 411 057, Maharashtra, India
Tel: (9120) 4200 2000
Fax: (9120) 4200 2099

Indonesia

BSD Taman Tekno 8
Jl. Tekno Widya Blok H10 No 2 & 3
Tangerang Selatan 15314
Indonesia
Tel: (6221) 2966 6242
Fax: (6221) 2966 6245

Japan

Shin-yokohama Tosho Building
No. 3-9-5 Shin-Yokohama, Kohoku-ku
Yokohama 222-0033 Japan
Tel: (8145) 475 6371
Fax: (8145) 475 3565

Malaysia

Level M2, Blk A, Menara PKNS-PJ
Jalan Yong Shook Lin
46050 Petaling Jaya, Selangor, Malaysia
Tel: (603) 7949 9222
Fax: (603) 7949 9333

Middle East & Africa

PO Box 26382
Jebel Ali Free Zone - South
Dubai, UAE
Tel: (9714) 811 8100
Fax: (9714) 886 5465

Philippines

10/F SM Cyber West Avenue, EDSA cor.
West Avenue, Barangay Bungad,
Diliman, Quezon City 1105 Philippines
Tel: (632) 689 7200

Saudi Arabia

PO Box 34332 - 3620 Building 7874
Unit 1, 67th street 2nd Industrial City
Dammam, Saudi Arabia
Toll Free: 800 844 3426
Tel: +966 3 8147560
Fax: +966 3 8147570

South Korea

3F, The Pinnacle Gangnam
343, Hakdong-ro, Gangnam-gu,
Seoul 06060, Republic of Korea
Tel: (822) 3483 1500
Fax: (822) 592 7883

Taiwan

3F No. 122 Lane 235,
Pao Chiau Rd., XinDianv Dist.,
New Taipei City 23145, Taiwan (R.O.C.)
Tel: (8862) 8912 1360
Fax: (8862) 8912 1890

Thailand

34th Floor, Interlink Tower,
1858/133, Bangna Trad,
Bangkok 10260, Thailand
Tel: (662) 716 4700
Fax: (662) 751 4241

United Arab Emirates

Jebel Ali Free Zone
PO Box 26382
Dubai UAE
Toll Free: 800 441 3428
Tel: +971 4 811 8100
Fax: +971 4 886 5465

Vietnam

Level 6, Melinh Point Tower,
2 Ngo Due Ke,
District 1, Ho Chi Minh City
Vietnam
Tel: (84) 908 009 189

Scan to visit:



Emerson Asia

Climate.Emerson.Com/Asia/Refrigeration

Asia 01 00 Issued 04/2020 Emerson is a trademark of Emerson Electric Co. or one of its affiliated companies.
©2020 Emerson Electric Co. All rights reserved.



@EmersonComResAP

EMERSON. CONSIDER IT SOLVED.™